



**MCK EQUIPMENT**  
Product Catalog



[mckonline.ca](http://mckonline.ca)





# ABOUT US

At **MCK Equipment**, we are proud to offer **direct-to-consumer (DTC)**

products as a premier manufacturer of high-quality kitchen and bar equipment. By controlling the entire production process we ensure that every product you purchase meets the highest standards of **durability, innovation, and reliability**.

We are able to provide you with:

- **Cost Efficiency:** Our products come directly from our manufacturing facility, meaning you benefit from lower prices by skipping the middleman.
- **Custom Solutions:** We offer customized equipment tailored to your unique needs, from layout designs to specific operational requirements.
- **Fast & Reliable Service:** We streamline the process, ensuring you receive your products quickly while maintaining the high level of quality and craftsmanship we're known for.
- **Expert Support:** You'll have direct access to our team of experts for product support, ensuring a seamless experience from purchase to installation.

With a focus on merging industry expertise with a dedication to quality and affordability, MCK Equipment ensures customers have access to premium supplies without compromising on price. Our approach to simplifying shopping for kitchen equipment further underscores their commitment to customer satisfaction, making quality kitchen essentials more accessible.

Our values guide everything we do, ensuring that we deliver excellence in products, service, and support to our customers and communities alike.



Toll free +1 (833) 978 8833  
sales@mckequipment.ca  
Visit [mckonline.ca](http://mckonline.ca) for more details

Quality Kitchen  
Equipment & Supplies



# From our factory to your restaurant, kitchen or bar. No middleman required.

Whether you need premium ovens, professional-grade grills, or custom refrigeration solutions, our products are crafted to meet the rigorous demands of commercial kitchens, bars, and even home enthusiasts. From food preparation essentials like slicers and mixers to top-tier refrigeration units and display warmers, we provide comprehensive solutions tailored to your operational needs. Additionally, our inventory includes fryers, pasta machines, steam equipment, and more, ensuring your kitchen or bar operates smoothly and efficiently with equipment designed for reliability and performance. Visit our online shop or stop by our showroom to discover the full range of MCK Equipment products. Our team is ready to help you equip your kitchen or bar with the best tools for success. **Build your dream restaurant & bar with us!**



## OUR MISSION

At MCK Equipment, our mission is simple: to become Canada's leading manufacturer and supplier of foodservice equipment and supplies. Our commitment to excellence, innovative technology, and a diverse workforce shines through in every product we offer.



Toll free +1 (833) 978 8833  
 sales@mckequipment.ca  
 Visit mckonline.ca for more details

# CONTACT US

## ALBERTA

### Calgary

Call us: +1 (833) 978 8833  
 sales@mckequipment.ca

### Edmonton

Call us: +1 (833) 978 8833  
 sales@mckequipment.ca

### Red Deer

Call us: +1 (833) 978 8833  
 sales@mckequipment.ca

## BRITISH COLUMBIA

### Vancouver

Call us: +1 (833) 978 8833  
 sales@mckequipment.ca

## SASKATCHEWAN

### Saskatoon

Call us: +1 (833) 978 8833  
 sales@mckequipment.ca

### Regina

Call us: +1 (833) 978 8833  
 sales@mckequipment.ca

### Prince Albert

Call us: +1 (833) 978 8833  
 sales@mckequipment.ca

### Battlefords

Call us: +1 (833) 978 8833  
 sales@mckequipment.ca

## Manitoba

### Winnipeg

Call us: +1 (833) 978 8833  
 sales@mckequipment.ca

## ONTARIO

### Ottawa

Call us: +1 (833) 978 8833  
 sales@mckequipment.ca

### Toronto

Call us: +1 (833) 978 8833  
 sales@mckequipment.ca

## QUEBEC

### Montreal

Call us: +1 (833) 978 8833  
 sales@mckequipment.ca

### Quebec City

Call us: +1 (833) 978 8833  
 sales@mckequipment.ca

# INFORMATION

### Online Support:

mckonline.ca/customer-help  
 sales@mckequipment.ca

### Warranty & Returns:

sales@mckequipment.ca

### Contact us:

Phone: +1 (833) 978 8833  
 Email: sales@mckequipment.ca  
 Website: mckonline.ca

Follow us on Facebook, Instagram, Youtube & LinkedIn under @mckequipment for updates, promotions and product launches.



Toll free +1 (833) 978 8833  
 sales@mckequipment.ca  
 Visit [mckonline.ca](http://mckonline.ca) for more details

Quality Kitchen  
 Equipment & Supplies



# VISIT OUR SHOWROOM:

## SASKATCHEWAN

### Saskatoon

3603 Millar Ave #4,  
 Saskatoon, SK S7P 0B2  
 +1 (833) 978 8833  
[saskatoon@mckequipment.ca](mailto:saskatoon@mckequipment.ca)



# SHOP OR QUOTE ONLINE

Discover unbeatable deals and premium kitchen equipment at MCK Equipment. Visit our website to shop online, or request a quote today. **Equip and build your dreamed restaurant kitchen and bar, start your journey with us now!**  
[mckonline.ca](http://mckonline.ca)  
[mckonline.ca/shop](http://mckonline.ca/shop)





# REFRIGERATION

## **BOTTOM MOUNT REACH-IN REFRIGERATORS & FREEZERS.....14**

Bottom Mount Reach-In Refrigerator.....15  
 Bottom Mount Reach-In Freezer.....17

## **BOTTOM MOUNT GLASS DOOR REACH-IN REFRIGERATORS & FREEZERS.....20**

Glass Door Reach-In Refrigerator.....21  
 Glass Door Reach-In Freezer.....23

## **GLASS DOOR MERCHANDISERS.....26**

Countertop Refrigerated Display Cases.....27  
 Refrigerated Display Cases.....29  
 Countertop Refrigerated Merchandiser.....41  
 Black Ext. Glass Door Refrigerator Merchandisers.....43  
 Black Ext. Sliding Glass Door Refrigerator Merchandisers.....47  
 Black Ext. Glass Door Freezer Merchandisers.....49

## **Refrigerated Open-Air Merchandiser.....52**

## **BAR EQUIPMENT.....63**

Back Bar Coolers Solid Doors Stainless Steel.....64  
 Back Bar Coolers Solid Doors.....66  
 Back Bar Coolers Glass Doors Stainless Steel.....68  
 Back Bar Coolers Glass Doors.....70  
 Back Bar Coolers Glass Sliding Doors Stainless Steel.....72  
 Back Bar Coolers Glass Sliding Doors.....74  
 Direct Draw Keg Cooler.....76

## **REF. SANDWICH PREP TABLES.....81**

Standard Top Sandwich / Salad Prep Tables.....82  
 Mega Top Sandwich / Salad Prep Tables.....86



**REF. PIZZA PREP TABLES.....91**  
 Refrigerated Pizza Prep Tables.....92

**UNDERCOUNTER & WORKTOPS REFRIGERATORS.....96**  
 Worktop Refrigerators.....98  
 Worktop Freezers.....100  
 Undercounter Refrigerators.....102  
 Undercounter Freezers.....104

**REFRIGERATED CHEF BASE.....106**  
 48", 52", 60", 72" and 76" .....108

**CHEST FREEZER.....112**  
 Solid Top Chest Freezer.....114  
 Angle Curved Glass Top Chest Freezer.....116

**UNDERCOUNTER ICE MAKERS.....118**  
 Bullet Ice Maker.....120  
 280 Lb Ice Machine.....122

**MODULAR ICE MACHINES.....124**  
 350 Lb. Ice Machine.....126  
 530 Lb. Ice Machine.....128

**ICE STORAGE BINS.....130**  
 400 LBS AND 700 L Ice Storage Bins.....132

**WINE COOLER.....134**  
 Double Zone Wine Cooler.....136

**CAKE DISPLAY COOLER.....138**  
 Countertop Curved Glass Cake Display.....140



# GAS EQUIPMENT

## COUNTERTOP COOKING EQUIPMENT.....144

Countertop Radiant Broilers.....	146
Countertop Rock Char Broilers.....	148
Manual Griddles.....	150
Thermostatic Griddles.....	154
Countertop Range (Hot Plates).....	156
Single & Double Stock Pot Stoves.....	158

## GAS RANGES.....160

Gas Ranges (4, 6, 8 & 10 burner models).....	162
Gas Ranges with Griddle Tops.....	164
36" Combination Gas Ranges.....	166
60" Combination Gas Ranges.....	168

## CHEESE MELTER AND SALAMANDER BROILER.....171

36" Infrared Cheese Melter (Range or, wall mount).....	173
36" Infrared Salamander Broiler (Range or, wall mount).....	175

## GAS FRYERS.....177

Digital Control 50 LB Fryer.....	179
Open Bin 40,50 LB Fryer.....	181
40, 50, 75 LBS Fryer.....	183
Fryer Filters.....	185

## Gas Ovens.....187

Single   Double Convection Gas Oven.....	188
--	-----



# FOOD PREPARATION

<b>SLICERS.....</b>	<b>193</b>
10" Compact Manual Slicer.....	195
12" Compact Manual Slicer.....	197
12" Heavy Duty Manual Slicer.....	199
14" Heavy Duty Slicer.....	201
14" Heavy Duty Automatic Slicer.....	203
<b>MIXERS.....</b>	<b>205</b>
Heavy Duty 10 Quart Planetary Mixer.....	207
Heavy Duty 20 Quart Planetary Mixer.....	209
Heavy Duty 30 Quart Planetary Mixer.....	211
Heavy Duty 40 Quart Planetary Mixer.....	213
Heavy Duty 60 Quart Planetary Mixer – Floor Model.....	215
<b>CURING CABINETS.....</b>	<b>217</b>
Meat Agers.....	219
<b>PROOFER.....</b>	<b>222</b>
Insulated Heater/Proofer/Holding Cabinets.....	223
<b>FOOD PROCESSORS AND BONE SAWS.....</b>	<b>225</b>
Meat Grinder.....	227
Vegetable Chopper & Cheese Slicer.....	229
Bowl Cutter Processor.....	231
Bone Saw.....	233
Immersion Blender.....	235



# FOOD PRESENTATION & DISPLAY

**WARMERS.....237**

Display Warmes.....239

Pizza Warmer.....245

Food Warmer.....247

# DISHWASHER EQUIPMENT

**DISHWASHER EQUIPMENT.....248**

Undercounter Dishwasher.....250

Hood Type Dishwasher.....252

# UTILITIES – STAINLESS STEEL

**SINKS, TABLES AND EQUIPMENT STANDS.....254**

S/S Tables.....256

S/S Shelves & Pot Hook Racks.....267

S/S Pan Racks.....270

S/S Sinks.....271

S/S Table with Sinks.....272

S/S Clean Dish Tables.....282

Bar Sinks.....286

ACCESSORIES.....290



# ELECTRIC EQUIPMENT

**Electric Cooking Equipment .....296**

Electric Egg Boiler.....297

Electric Crepe Maker.....299

Electric Waffle Maker.....301

Electric Conveyor Toaster.....302

Electric Pasta Cooker Single | Double.....304

Electric Manual Toasters.....309

Electric Fryer.....311

## Beverage Dispensers

**Beverage Dispensers.....317**

Juice Dispenser.....318

Slush Dispenser.....319

Coffee Urn.....320

## Electric Ovens

**Electric Ovens.....322**

Pizza Single Chamber Electric oven.....324

Single | Double Convection Electric oven.....326

# FURNITURE

**FURNITURE.....330**

Restaurant Seating.....332

Restaurant Tables.....337



Toll free +1 (833) 978 8833  
 sales@mckequipment.ca  
 Visit [mckonline.ca](http://mckonline.ca) for more details

Quality Kitchen  
 Equipment & Supplies



# WARRANTY POLICY

Refrigeration, Chest Freezers, Countertop Equipment & Ice Machines.  
 .....340  
 Cooking & Holding Equipment.....342  
 Mixers, Slicers and Meat Grinders.....344  
 Stainless Steel (S/S) Equipment.....346  
 Kitchen Hoods.....348

# CONTACT

Contact us.....350  
 Showroom information.....351



Toll free +1 (833) 978 8833  
sales@mckequipment.ca  
Visit [mckonline.ca](http://mckonline.ca) for more details



# **BOTTOM MOUNT REACH-IN REFRIGERATORS & FREEZERS**



Toll free +1 (833) 978 8833  
 sales@mckequipment.ca  
 Visit [mckonline.ca](http://mckonline.ca) for more details



# Bottom Mount Reach-In Refrigerator

## FEATURES:

- Maintains temperatures from 33 degrees F to 40 degrees F
- Down duct refrigeration system ensures even air distribution
- Three pre-installed shelves per section
- Interior LED lighting
- Stainless steel interior and exterior
- Magnetic door gaskets for a secure seal
- Standard door locks
- Recessed door handles
- Dixell digital temperature controller
- Pre-installed casters for easy mobility
- Environmentally friendly R290 refrigerant with bottom mount compressor units

## OTHER ACCESSORIES

- Includes 4 clips per shelf



MCK-GD-STH27BR  
 MCK-CFD-IRR-HC



MCK-GD-STH54BR  
 MCK-CFD-2RR-HC



MCK-GD-STH81BR  
 MCK-CFD-3RR-HC

*Don't forget to leave the unit some room to breathe!  
 Please clean the condenser frequently  
 to give the unit more fresh air.*





## SPECIFICATIONS

Model	Door	Capacity (Cu. Ft.)	Shelves	Casters (Inch)	Rated Current (A)	Voltage (V/Hz/Ph)	HP	Refrigerant	Exterior Dimensions (W x D x H inch)	Net Weight (lbs)	Gross Weight (lbs)
MCK-GD-STH27BR MCK-CFD-1RR-HC	1	23	3	4	2.6	115/60/1	1/5	R290	29 x 32 1/4 x 82 1/2	261	286
MCK-GD-STH54BR MCK-CFD-2RR-HC	2	47	6	4	4.3	115/60/1	1/4+	R290	54 x 32 1/4 x 82 1/2	446	495
MCK-GD-STH81BR MCK-CFD-3RR-HC	3	72	9	2	9.1	115/60/1	3/4	R290	80 9/10 x 32 1/4 x 82 1/2	602	615

## PLAN VIEW

MCK-GD-STH27BR  
MCK-CFD-1RR-HC

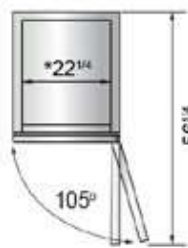

MCK-GD-STH54BR  
MCK-CFD-2RR-HC

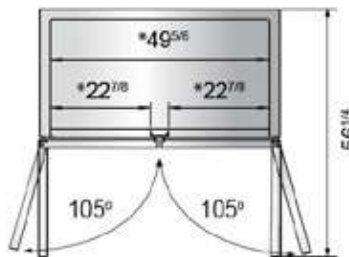

MCK-GD-STH81BR  
MCK-CFD-3RR-HC

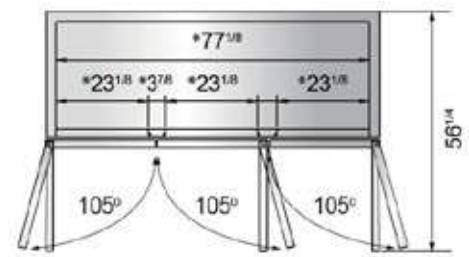

Casters



Epoxy shelves



Door lock



Down duct



Temperature control





Toll free +1 (833) 978 8833  
 sales@mckequipment.ca  
 Visit [mckonline.ca](http://mckonline.ca) for more details



# Bottom Mount Reach-In Freezer

## FEATURES:

- Maintains temperatures from -10 F to 10 F
- Down duct refrigeration system ensures even air distribution
- Three pre-installed shelves per section
- Interior LED lighting
- Stainless steel interior and exterior
- Magnetic door gaskets for a secure seal
- Standard door locks
- Recessed door handles
- Dixell digital temperature controller
- Pre-installed casters for easy mobility
- Environmentally friendly R290 refrigerant with bottom mount compressor units

## OTHER ACCESSORIES

- includes 4 clips per shelf



MCK-GD-STH-27BF  
 MCK-CFD-1FF-HC



MCK-GD-STH-54BF  
 MCK-CFD-2FF-HC



MCK-GD-STH-81BF  
 MCK-CFD-3FF-HC

*Don't forget to leave the unit some room to breathe!  
 Please clean the condenser frequently  
 to give the unit more fresh air.*





Toll free +1 (833) 978 8833  
 sales@mckequipment.ca  
 Visit [mckonline.ca](http://mckonline.ca) for more details

Quality Kitchen  
 Equipment & Supplies



## SPECIFICATIONS

Model	Door	Capacity (Cu. Ft.)	Shelves	Casters (Inch)	Rated Current (A)	Voltage (V/Hz/Ph)	HP	Refrigerant	Exterior Dimensions (W x D x H inch)	Net Weight (lbs)	Gross Weight (lbs)
MCK-GD-STH-27BF MCK-CFD-1FF-HC	1	23	3	4	7.1	115/60/1	1/5	R290	29 × 32 1/4 × 82 1/2	257	282
MCK-GD-STH-54BF MCK-CFD-2FF-HC	2	47	6	4	10.7	115/60/1	1/4+	R290	54 × 32 1/4 × 82 1/2	441	447
MCK-GD-STH-81BF MCK-CFD-3FF-HC	3	72	9	2	12	115/60/1	3/4	R290	80 9/10 × 32 1/4 × 82 1/2	602	615

## PLAN VIEW

MCK-GD-STH-27BF  
MCK-CFD-1FF-HC

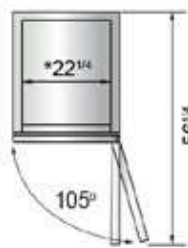

MCK-GD-STH-54BF  
MCK-CFD-2FF-HC

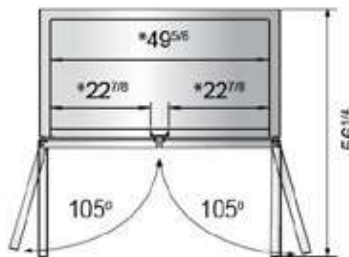

MCK-GD-STH-81BF  
MCK-CFD-3FF-HC

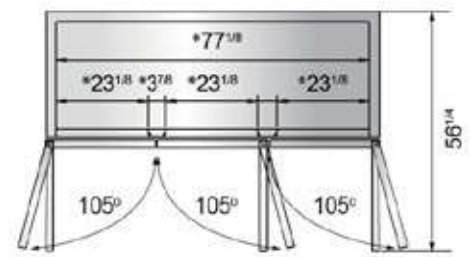

Casters

Epoxy shelves

Door lock

Down duct

Temperature control





Toll free +1 (833) 978 8833  
sales@mckequipment.ca  
Visit [mckonline.ca](http://mckonline.ca) for more details



MCK Equipment | [info@mckequipment.ca](mailto:info@mckequipment.ca)  
Visit [mckonline.ca](http://mckonline.ca) for more details

# **BUTTON MOUNT GLASS DOOR REACH-IN REFRIGERATORS & FREEZERS**



Toll free +1 (833) 978 8833  
 sales@mckequipment.ca  
 Visit [mckonline.ca](http://mckonline.ca) for more details

Quality Kitchen  
 Equipment & Supplies



# Glass Door Reach-In Refrigerator

## FEATURES:

- Stainless steel exterior & interior
- LED interior lights
- Heavy duty Embraco compressor with environmentally friendly R290 refrigerant
- Digital controller
- Maintains temperatures between 33F - 38F
- Self-closing door(s) with automatic stay open feature
- Recessed door handle(s)
- Magnetic door gasket
- Double pane glass door
- Pre-installed casters
- NEMA-5-15P plug standard
- Four(4) pre-installed shelves per section



MCK-CFD-IRRG-HC  
 MCK-GD-STH-27RG



MCK-CFD-2RRG-HC  
 MCK-GD-STH-54RG

*Don't forget to leave the unit some room to breathe!  
 Please clean the condenser frequently  
 to give the unit more fresh air.*





Toll free +1 (833) 978 8833  
 sales@mckequipment.ca  
 Visit [mckonline.ca](http://mckonline.ca) for more details



## SPECIFICATIONS

Model	Door	Capacity (Cu. Ft.)	Shelves	Casters (Inch)	Rated Current (A)	Voltage (V/Hz/Ph)	HP	Refrigerant	Exterior Dimensions (W x D x H inch)	Net Weight (lbs)	Gross Weight (lbs)
MCK-CFD-1RRG-HC MCK-GD-STH-27RG	1	21	3	4	2.1	115/60/1	1/7	R290	27 x 33 1/2 x 83 1/2	267	294
MCK-CFD-2RRG-HC MCK-GD-STH-54RG	2	46	6	4	3.2	115/60/1	1/5	R290	54 2/5 x 33 1/2 x 83 1/2	412	453

## PLAN VIEW

MCK-CFD-1RRG-HC  
MCK-GD-STH-27RG

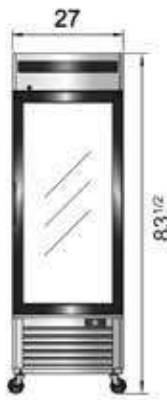

MCK-CFD-2RRG-HC  
MCK-GD-STH-54RG

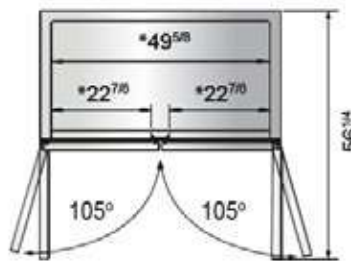
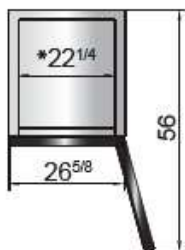

Casters

Epoxy shelves

Door lock

Down duct

Temperature control





Toll free +1 (833) 978 8833  
 sales@mckequipment.ca  
 Visit [mckonline.ca](http://mckonline.ca) for more details

Quality Kitchen  
 Equipment & Supplies



# Glass Door Reach-In Freezer

## FEATURES

- Stainless steel exterior & interior
- LED interior lights
- Heavy duty Embraco compressor with environmentally friendly R290 refrigerant
- Digital controller
- Maintains temperatures between -10°F – 10°F
- Automatic Defrosting
- Self-closing door(s) with automatic stay open feature
- Standard door lock
- Recessed door handle(s)
- Magnetic door gasket
- Double pane glass door
- Pre-installed casters
- NEMA-5-15P plug standard
- 4 Pre-installed shelves per section



**MCK-CFD-1FFG-HC**  
**MCK-GD-STH-27FG**



**MCK-CFD-2FFG-HC**  
**MCK-GD-STH-54FG**

*Don't forget to leave the unit some room to breathe!  
 Please clean the condenser frequently  
 to give the unit more fresh air.*





## SPECIFICATIONS

Model	Door	Capacity (Cu. Ft.)	Shelves	Casters (Inch)	Rated Current (A)	Voltage (V/Hz/Ph)	HP	Refrigerant	Exterior Dimensions (W x D x H inch)	Net Weight (lbs)	Gross Weight (lbs)
MCK-CFD-1FFG-HC MCK-GD-STH-27FG	1	21	3	4	2.6	115/60/1	1/3	R290	27× 33 1/2× 83 1/2	267	294
MCK-CFD-2FFG-HC MCK-GD-STH-54FG	2	46	6	4	4.0	115/60/1	1/3	R290	54 2/5 × 33 1/2× 83 1/2	412	453

## PLAN VIEW

MCK-CFD-1FFG-HC  
MCK-GD-STH-27FG

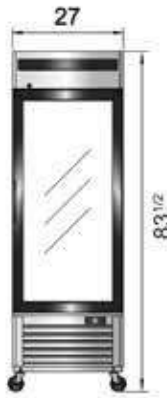

MCK-CFD-2FFG-HC  
MCK-GD-STH-54FG

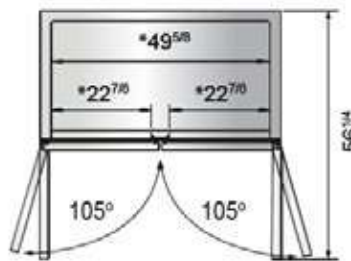
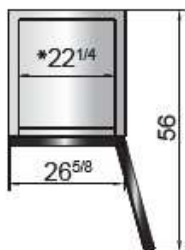

Casters

Epoxy shelves

Door lock

Down duct

Temperature control





Toll free +1 (833) 978 8833  
sales@mckequipment.ca  
Visit [mckonline.ca](http://mckonline.ca) for more details



## **GLASS DOOR MERCHANDISERS**

Countertop Glassdoor Merchandisers  
Countertop Refrigerated Display Cases -  
Curved/Square  
Black Exterior Glass Door  
Refrigerator Merchandisers



Toll free +1 (833) 978 8833  
 sales@mckequipment.ca  
 Visit [mckonline.ca](http://mckonline.ca) for more details

Quality Kitchen  
 Equipment & Supplies



# Countertop Refrigerated Display Cases

MCK-FTW-100L | MCK-FTW-120L | MCK-FTW-150L |  
 MCK-FTW-160L | MCK-FTW-200L

## FEATURES

- Stainless steel exterior and interior with black frames
- Rear mount compressor with environmentally friendly R290 refrigerant
- Digital controller
- Stainless steel shelves
- Defog feature to ensure the glass stays clear
- Maintains temperatures between 35F - 53F
- Two(2) rear sliding doors
- Leveling legs



MCK-FTW-100L



MCK-FTW-120L



MCK-FTW-150L



MCK-FTW-160L



MCK-FTW-200L

**Don't forget to leave the unit some room to breathe!**  
 Please clean the condenser frequently to give the unit more fresh air.





## SPECIFICATIONS

Model	Door	Capacity (L)	Shelves	Rated Current (A)	Voltage (V/Hz)	Power (W)	Refrigerant	Exterior Dimensions (D x W x H inch)	Net Weight (lbs)	Gross Weight (lbs)
MCK-FTW-100L	2	100	2	2	110-120/60	210	R290	18 1/10 × 26 9/10 × 26 3/5	88.2	97
MCK-FTW-120L	2	120	2	2.2	110-120/60	240	R290	22 3/5 × 27 7/10 × 27	125.6	138
MCK-FTW-150L	2	150	4	1.86	110-120/60	215	R290	21 4/5 × 26 3/10 × 35	135.5	149
MCK-FTW-160L	2	160	2	2.2	110-120/60	240	R290	22 3/5 × 34 9/10 × 27	145.5	160
MCK-FTW-200L	2	200	2	3.45	110-120/60	370	R290	22 3/5 × 48 1/5 × 27	198.4	218

## PLAN VIEW

MCK-FTW-100L

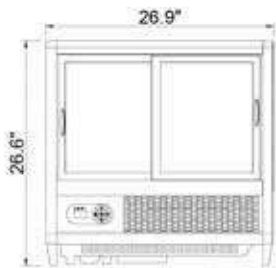

MCK-FTW-120L

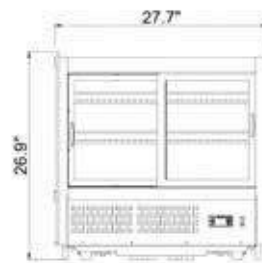

MCK-FTW-150L



MCK-FTW-160L



MCK-FTW-200L

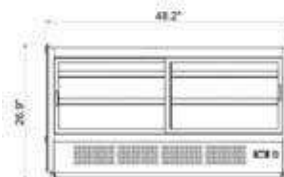

Side View



Curved Glass

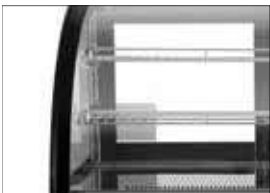

Square



Digital Controller



Leg



Sliding Doors





Toll free +1 (833) 978 8833  
 sales@mckequipment.ca  
 Visit [mckonline.ca](http://mckonline.ca) for more details

Quality Kitchen  
 Equipment & Supplies



# Refrigerated Display Cases

## FEATURES:

- Stainless steel exterior & interior with black frames
- Rear mount compressor with environmentally friendly R290 refrigerant
- Electronic temperature controller
- Defog feature to ensure the glass stays clear
- Maintains temperatures between 35°F – 38°F
- Magnetic door gasket(s) standard for positive door seal
- Two (2) rear sliding doors
- LED interior lighting



**FT-270R-1 | 370R-1 | 470R-1 | 570R-1**



**FT-270Y-1 | FT-370Y-1 | FT-470Y-1**

*Don't forget to leave the unit some room to breathe!  
 Please clean the condenser frequently  
 to give the unit more fresh air.*





Toll free +1 (833) 978 8833  
 sales@mckequipment.ca  
 Visit [mckonline.ca](http://mckonline.ca) for more details

Quality Kitchen  
 Equipment & Supplies



**FT-275Y-1 | FT-475Y-1**



**FT-270Z-1 | FT-370Z-1 | FT-470Z-1 | FT-570Z-1**



**FT-375Y-1 | FT-575Y-1**



Toll free +1 (833) 978 8833  
 sales@mckequipment.ca  
 Visit [mckonline.ca](http://mckonline.ca) for more details

Quality Kitchen  
 Equipment & Supplies



**FT-380R | FT-520R | FT-620R | FT-720R**

**Back**



**FT-380Z | FT-520Z | FT-620Z | FT-720Z**

**Back**



**SPECIFICATIONS**

<b>Model Number</b>	<b>Description</b>	<b>Size (inches)</b>	<b>Net Weight (lbs)</b>	<b>Gross Weight (lbs)</b>
<b>FT-270R-1</b>	110V/60Hz, R290, 3 LED light, US plug	37.36" x 26.97" x 47.44"	265	328
<b>FT-370R-1</b>	110V/60Hz, R290, 3 LED light, US plug	49.17" x 26.97" x 47.44"	309	381
<b>FT-470R-1</b>	110V/60Hz, R290, 3 LED light, US plug	60.98" x 26.97" x 47.44"	368	474
<b>FT-570R-1</b>	110V/60Hz, R290, 3 LED light, US plug	72.80" x 26.97" x 47.44"	452	540
<b>FT-270Y-1</b>	110V/60Hz, R290, 3 LED light, US plug	37.36" x 26.97" x 47.72"	298	340
<b>FT-370Y-1</b>	110V/60Hz, R290, 3 LED light, US plug	49.17" x 26.97" x 47.72"	342	414
<b>FT-470Y-1</b>	110V/60Hz, R290, 3 LED light, US plug	63.98" x 30.12" x 51.57"	401	507



Toll free +1 (833) 978 8833  
 sales@mckequipment.ca  
 Visit [mckonline.ca](http://mckonline.ca) for more details



**SPECIFICATIONS**

<b>Model Number</b>	<b>Description</b>	<b>Size (inches)</b>	<b>Net Weight (lbs)</b>	<b>Gross Weight (lbs)</b>
<b>ft-275Y-1</b>	110V/60Hz, R290, 3 LED light, US plug	37.36" x 27.13" x 55.31"	348	417
<b>FT-475Y-1</b>	110V/60Hz, R290, 3 LED light, US plug	60.98 x 27.13 x 55.31	463	542
<b>FT-270Z-1</b>	110V/60Hz, R290, 3 LED light, US plug	37.36 x 26.97 x 47.44	298	340
<b>FT-370Z-1</b>	110V/60Hz, R290, 3 LED light, US plug	49.17 x 26.97 x 47.44	342	414



Toll free +1 (833) 978 8833  
sales@mckequipment.ca  
Visit [mckonline.ca](http://mckonline.ca) for more details

<b>Model Number</b>	<b>Description</b>	<b>Size (inches)</b>	<b>Net Weight (lbs)</b>	<b>Gross Weight (lbs)</b>
<b>FT-470Z-1</b>	110V/60Hz, R290, 3 LED light, US plug	60.98 x 26.97 x 47.44	401	507
<b>FT-570Z-1</b>	110V/60Hz, R290, 3 LED light, US plug	72.80 x 26.97 x 47.44	496	573
<b>FT-375Y-1</b>	110V/60Hz, R290, 3 LED light, US plug	49.17 x 27.13 x 55.31	390	467
<b>FT-575Y-1</b>	110V/60Hz, R290, 3 LED light, US plug	72.80 x 27.13 x 55.31	518	617
<b>FT-380R</b>	110V/60Hz, R290, 3 LED light, US plug	35.43 x 27.56 x 49.21	298	375
<b>FT-520R</b>	110V/60Hz, R290, 3 LED light, US plug	47.24 x 27.56 x 49.21	395	483
<b>FT-620R</b>	110V/60Hz, R290, 3 LED light, US plug	59.06 x 27.56 x 49.21	496	562



Toll free +1 (833) 978 8833  
 sales@mckequipment.ca  
 Visit [mckonline.ca](http://mckonline.ca) for more details



**SPECIFICATIONS**

<b>Model Number</b>	<b>Description</b>	<b>Size (inches)</b>	<b>Net Weight (lbs)</b>	<b>Gross Weight (lbs)</b>
<b>FT-720R</b>	110V/60Hz, R290, 3 LED light, US plug	70.87 x 27.56 x 49.21	584	650
<b>FT-380Z</b>	110V/60Hz, R290, 3 LED light, US plug	38.19 x 30.31 x 52.36	298	170
<b>FT-520Z</b>	110V/60Hz, R290, 3 LED light, US plug	47.24 x 27.56 x 49.02	423	507
<b>FT-620Z</b>	110V/60Hz, R290, 3 LED light, US plug	59.06 x 27.56 x 49.02	496	562
<b>FT-720Z</b>	110V/60Hz, R290, 3 LED light, US plug	70.87 x 27.56 x 49.02	584	650



Toll free +1 (833) 978 8833  
 sales@mckequipment.ca  
 Visit [mckonline.ca](http://mckonline.ca) for more details



# Refrigerated Display Cases

MCK-FT-58L | MCK-FT-68L | MCK-FT-78L |  
 MCK-FT-98L

## FEATURES

- Four sided glass body with black framing & base. Double layer glass on all sides
- Interior LED lighting on all four sides
- Swing open front and rear door
- Locks on front and rear side to control customer access
- 2 adjustable chrome plated shelves
- Environmentally friendly R290 refrigerant
- Digital controller & defrost timer
- Maintains temperatures between 32°F – 53°F



MCK-FT-58L



MCK-FT-68L



MCK-FT-98L



MCK-FT-78L

*Don't forget to leave the unit some room to breathe!  
 Please clean the condenser frequently  
 to give the unit more fresh air.*





Toll free +1 (833) 978 8833  
 sales@mckequipment.ca  
 Visit [mckonline.ca](http://mckonline.ca) for more details

Quality Kitchen  
 Equipment & Supplies



## SPECIFICATIONS

Model	Capacity (L)	Shelves	Rated Current (A)	Voltage (V/Hz/Ph)	HP (W)	Refrigerant	Exterior Dimensions (W x L x H)	Net Weight (lbs)	Gross Weight (lbs)
MCK-FT-58L	58	2	2.45	110/60/1	235	R290	16 x 17.8 x 32.2	71	74
MCK-FT-68L	68	3	2.45	110/60/1	235	R290	16 x 17.8 x 35.2	77	81
MCK-FT-78L	78	3	2.45	110/60/1	235	R290	16 x 17.8 x 38.6	78	82
MCK-FT-98L	98	4	2.45	110/60/1	235	R290	16 x 17.8 x 44	98	103

## PLAN VIEW

MCK-FT-58L

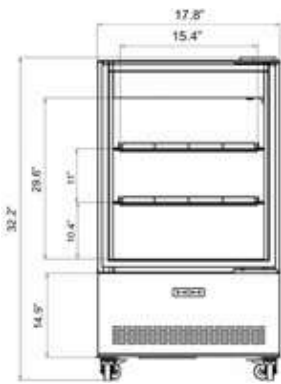

MCK-FT-68L



MCK-FT-78L



MCK-FT-98L

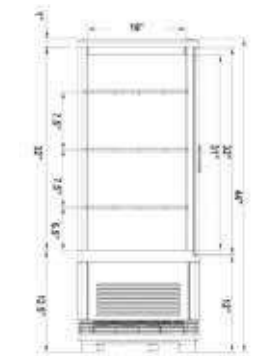

Shelves



Digital Control



Door Handle



Adjustable



Legs





Toll free +1 (833) 978 8833  
 sales@mckequipment.ca  
 Visit [mckonline.ca](http://mckonline.ca) for more details

Quality Kitchen  
 Equipment & Supplies



# Refrigerated Display Cases

MCK-FT-215L | MCK-FT-235L | MCK-FT-280L |  
 MCK-FT-290L

## FEATURES

- Four sided glass body with black framing & base. Double layer glass on all sides Interior LED lighting on all four sides
- Swing open front and rear door
- Locks on front and rear side to control customer access
- Adjustable shelves
- Environmentally friendly R290 refrigerant
- Digital controller & defrost timer • Maintains temperatures between 32°F – 53°F



MCK-FT-215L



MCK-FT-235L



MCK-FT-290L



MCK-FT-280L

*Don't forget to leave the unit some room to breathe!  
 Please clean the condenser frequently  
 to give the unit more fresh air.*





Toll free +1 (833) 978 8833  
 sales@mckequipment.ca  
 Visit [mckonline.ca](http://mckonline.ca) for more details

Quality Kitchen  
 Equipment & Supplies



## SPECIFICATIONS

Model	Capacity (L)	Shelves	Rated Current (A)	Voltage (V/Hz/Ph)	HP (W)	Refrigerant	Exterior Dimensions (W x L x H)	Net Weight (lbs)	Gross Weight (lbs)
MCK-FT-215L	215	4	3.55	110/60/1	340	R290	19.1 x 20.3 x 63.1	161	169
MCK-FT-235L	235	4	3.55	110/60/1	340	R290	19.1 x 20.3 x 67	167	176
MCK-FT-280L	270	5	3.55	110/60/1	340	R290	19.1 x 20.3 x 74	196	206
MCK-FT-290L	280	6	3.55	110/60/1	340	R290	19.1 x 20.3 x 78	201	211

## PLAN VIEW

MCK-FT-215L



MCK-FT-235L

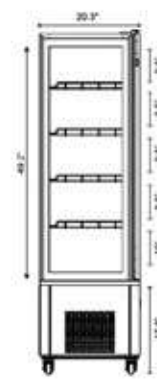
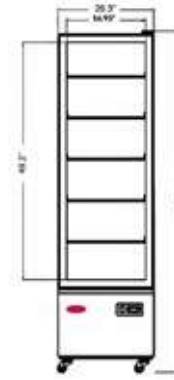
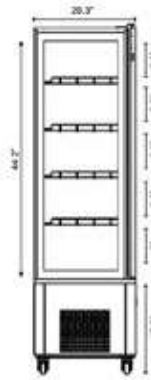

MCK-FT-280L

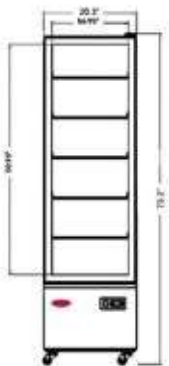

MCK-FT-290L

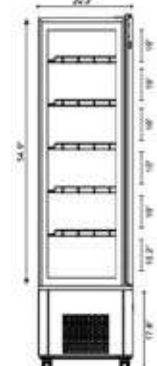
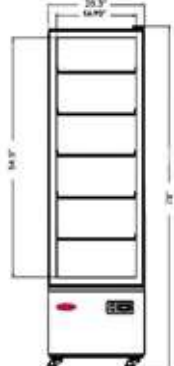
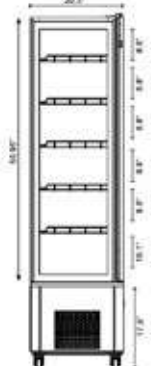

Shelves



Digital Control



Door Handle



Adjustable



Caster





Toll free +1 (833) 978 8833  
 sales@mckequipment.ca  
 Visit [mckonline.ca](http://mckonline.ca) for more details

Quality Kitchen  
 Equipment & Supplies



# Refrigerated Display Cases

MCK-FT-400L



MCK-FT-300L



## SPECIFICATIONS

Model	Capacity (L)	Shelves	Rated Current (A)	Voltage (V/Hz/Ph)	HP (W)	Refrigeration	Exterior Dimensions (W x L x H)	Net Weight (lbs)	Gross Weight (lbs)
MCK-FT-215L	215	4	3.55	110/60/1	340	R290	19.1 x 20.3 x 63.1	161	169
MCK-FT-235L	235	4	3.55	110/60/1	340	R290	19.1 x 20.3 x 67	167	176
MCK-FT-280L	270	5	3.55	110/60/1	340	R290	19.1 x 20.3 x 74	196	206
MCK-FT-290L	280	6	3.55	110/60/1	340	R290	19.1 x 20.3 x 78	201	211
MCK-FT-300L	300	3	3.55	110/60/1	340	R290	25.7 x 31.9 x 57.2	289	348
MCK-FT-400L	400	3	3.55	110/60/1	340	R290	47.2 x 31.9 x 57.2	448	503



Toll free +1 (833) 978 8833  
 sales@mckequipment.ca  
 Visit [mckonline.ca](http://mckonline.ca) for more details

Quality Kitchen  
 Equipment & Supplies



# Countertop Refrigerated Merchandiser

MCK-G138BMF-HC | MCK-G188BMF-HC

## FEATURES

- Coated steel exterior in black color.
- Aluminum interior liner with stainless steel floor.
- Rear mount compressor with environmentally friendly R290 refrigerant.
- Digital temperature controller
- Led lighting
- Adjustable PVC shelves
- Defog feature to ensure the glass stays clear
- Maintains temperatures between 33F - 41F
- One (1) swing glass door
- Leveling legs



MCK-G138BMF-HC



MCK-G188BMF-HC

*Don't forget to leave the unit some room to breathe!  
 Please clean the condenser frequently  
 to give the unit more fresh air.*





Toll free +1 (833) 978 8833  
 sales@mckequipment.ca  
 Visit [mckonline.ca](http://mckonline.ca) for more details

Quality Kitchen  
 Equipment & Supplies



## SPECIFICATIONS

Model	Door	Capacity (Cu. Ft./L)	Shelves	Legs	Rated Current (A)	Voltage (V/Hz/Ph)	HP	Refrigerant	Exterior Dimensions	Net Weight (lbs)	Gross Weight (lbs)
MCK-G138BMF-HC	1	5 / 140	2	4	1.8	115/60/1	1/5	R290	24 2/5 x 25 1/5 x 33 1/4	126	138
MCK-G188BMF-HC	1	6.4 / 180	3	4	2	115/60/1	1/5	R290	24 2/5 x 25 1/5 x 38 1/4	140	156

## PLAN VIEW

MCK-G138BMF-HC

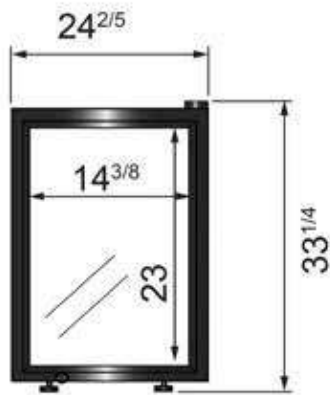

MCK-G188BMF-HC

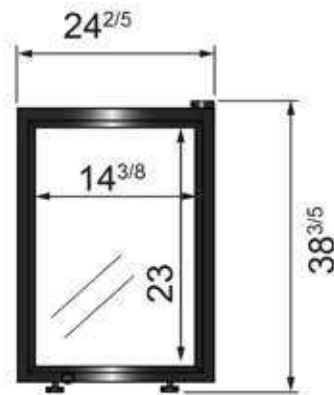

PVC Shelves



Led Lights



Legs



Adjustable





Toll free +1 (833) 978 8833  
 sales@mckequipment.ca  
 Visit [mckonline.ca](http://mckonline.ca) for more details

Quality Kitchen  
 Equipment & Supplies



# Black Ext. Glass Door Refrigerator Merchandisers

MCK-G258BMF-HC | MCK-G398BMF-HC |  
 MCK-G648BMF-HC

## FEATURES

- Black steel exterior with stainless steel interior
- LED interior lighting standard
- Electronic Temperature controller
- Adjustable shelves
- Maintains temperatures between 33 degrees F - 41 degrees F
- Self-closing door(s) with automatic stay open feature
- Door lock(s) standard and magnetic door gasket
- Self-contained bottom mount
- Environmentally R290 refrigerant



MCK-G258BMF-HC



MCK-G398BMF-HC



MCK-G648BMF-HC

*Don't forget to leave the unit some room to breathe!  
 Please clean the condenser frequently  
 to give the unit more fresh air.*





Toll free +1 (833) 978 8833  
 sales@mckequipment.ca  
 Visit [mckonline.ca](http://mckonline.ca) for more details

Quality Kitchen  
 Equipment & Supplies



## SPECIFICATIONS

Model	Door	Capacity (Cu. Ft.)	Shelves	Casters (Inch)	Rated Current (A)	Voltage (V/Hz/Ph)	HP	Refrigerant	Exterior Dimensions	Net Weight (lbs)	Gross Weight (lbs)
MCK-G258BMF-HC	1	19.4	4	4	2.88	115/60/1	1/3	R290	18.9 x 18.3 x 46.1	86	102
MCK-G398BMF-HC	1	43.8	4	4	2.88	115/60/1	1/3	R290	22.8 x 19.5 x 55.5	120	135
MCK-G648BMF-HC	1	69.5	4	4	3	115/60/1	4/9	R290	25.2 x 28.3 x 62.5	145	160

## PLAN VIEW

MCK-G258BMF-HC



MCK-G398BMF-HC



MCK-G648BMF-HC



\* Interior Dimensions

Adjustable Shelf



Door Handle



LED light



Door lock



Casters





Toll free +1 (833) 978 8833  
 sales@mckequipment.ca  
 Visit [mckonline.ca](http://mckonline.ca) for more details

Quality Kitchen  
 Equipment & Supplies



# Black Ext. Glass Door Refrigerator Merchandisers

MCK-GD-SC690F | MCK-GD-SC1390F |  
 MCK-GD-SC2090F

## FEATURES

- Black steel exterior with stainless steel interior
- Lighted header panel
- LED interior lighting standard
- Maintains temperatures between 32°F – 44°F
- Electronic Temperature controller
- Four(4) adjustable shelves standard per section
- Double pane glass door(s)
- Self-closing door(s) with automatic stay open
- Automatic defrosting every 6 hr
- Recessed door handle
- Magnetic door gasket
- Pre-installed casters
- Pre-installed shelves
- NEMA-5-15P plug standard



MCK-GD-SC690F



MCK-GD-SC1390F



MCK-GD-SC2090F

*Don't forget to leave the unit some room to breathe!  
 Please clean the condenser frequently  
 to give the unit more fresh air.*





## SPECIFICATIONS

Model	Door	Capacity (Cu. Ft.)	Shelves	Casters (Inch)	Rated Current (A)	Voltage (V/Hz/Ph)	HP	Refrigerant	Exterior Dimensions (W x D x H inch)	Net Weight (lbs)	Gross Weight (lbs)
MCK-GD-SC690F	1	19.2	4	2	3.5	115/60/1	1/6	R290	27 x 33 1/2 x 83	242	286
MCK-GD-SC1390F	2	44.7	8	2	4.6	115/60/1	1/5	R290	54 2/5 x 33 1/2 x 83	385	462
MCK-GD-SC2090F	3	70	12	2	9	115/60/1	3/8	R290	81 x 33 1/2 x 83	595	701

## PLAN VIEW

MCK-GD-SC690F

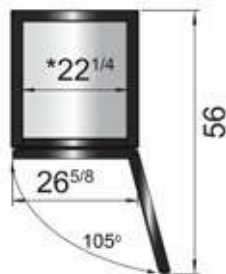

MCK-GD-SC1390F

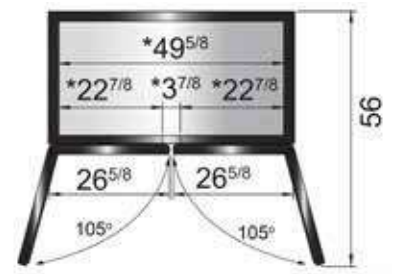

MCK-GD-SC2090F

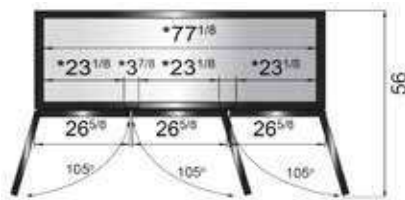

Side Dimension



\* Interior Dimensions

Door Handle



Temp. Control



LED light



Door lock



Casters





Toll free +1 (833) 978 8833  
 sales@mckequipment.ca  
 Visit [mckonline.ca](http://mckonline.ca) for more details

Quality Kitchen  
 Equipment & Supplies



# Black Ext. Sliding Glass Door Refrigerator Merch

MCK-G938YBM2-HC

## FEATURES

- Black steel exterior with stainless steel interior
- Lighted header panel
- LED interior lighting standard
- Carel electronic controller
- Maintains temperatures between 33F - 40F
- Four (4) shelves standard per section
- Double pane glass door(s)
- Door lock(s) standard
- Magnetic door gasket
- Environmentally friendly R290 refrigerant
- Pre-installed casters
- Pre-installed shelves
- NEMA-5-15P plug standard



## OTHER ACCESSORIES

- Extra shelves - includes 4 shelf clip per shelf

MCK-G938YBM2-HC

*Don't forget to leave the unit some room to breathe!  
 Please clean the condenser frequently  
 to give the unit more fresh air.*



MCK Equipment  
 mckonline.ca

**Please be informed:** Product specifications or design are subject to change without notice. Notify any special requirement to your sales representative.



Toll free +1 (833) 978 8833  
 sales@mckequipment.ca  
 Visit [mckonline.ca](http://mckonline.ca) for more details



## SPECIFICATIONS

Model	Door	Capacity (Cu. Ft./L)	Shelves	Casters (inch)	Rated Current (A)	Voltage (V/Hz/Ph)	HP	Refrigerant	Exterior Dimensions	Net Weight (lbs)	Gross Weight (lbs)
MCK-G938YBM2-HC	2	33/ 950	8	2	3.3	115/60/1	1/4	R290	39 1/2 x 28 x 83	305	511

## PLAN VIEW

MCK-G938YBM2-HC



Epoxy Shelves



Temp. Control



LED light



Door lock



Casters





Toll free +1 (833) 978 8833  
 sales@mckequipment.ca  
 Visit [mckonline.ca](http://mckonline.ca) for more details

Quality Kitchen  
 Equipment & Supplies



# Black Ext. Glass Door Freezer Merchandisers

MCK-GD-SD690F | MCK-GD-SD1390F |  
 MCK-GD-SD2090F

## FEATURES

- Black steel exterior with stainless steel interior
- Lighted header panel
- LED interior lighting standard
- Maintains temperatures between -8°F to -1°F
- Electronic Temperature controller
- Four (4) adjustable shelves standard per section
- Double pane glass door(s)
- Self-closing door(s) with automatic stay open
- Automatic defrosting every 6 hr
- Recessed door handle
- Magnetic door gasket
- Pre-installed casters
- Pre-installed shelves
- NEMA-5-15P plug standard



MCK-GD-SC690F



MCK-GD-SC1390F



MCK-GD-SC2090F

*Don't forget to leave the unit some room to breathe!  
 Please clean the condenser frequently  
 to give the unit more fresh air.*





Toll free +1 (833) 978 8833  
 sales@mckequipment.ca  
 Visit [mckonline.ca](http://mckonline.ca) for more details

Quality Kitchen  
 Equipment & Supplies



## SPECIFICATIONS

Model	Door	Capacity (Cu. Ft.)	Shelves	Casters (Inch)	Rated Current (A)	Voltage (V/Hz/Ph)	HP	Refrigerant	Exterior Dimensions (W x D x H inch)	Net Weight (lbs)	Gross Weight (lbs)
MCK-GD-SC690F	1	19.2	3	2	6.7	115/60/1	3/8	R290	27 x 33 1/2 x 83	247	291
MCK-GD-SC1390F	2	44.7	6	2	11.8	115/60/1	1	R290	54 2/5 x 33 1/2 x 83	396	474
MCK-GD-SC2090F	3	70	9	2	17	115/60/1	1/2*2	R290	81 x 33 1/2 x 83	639	745

## PLAN VIEW

MCK-GD-SC690F

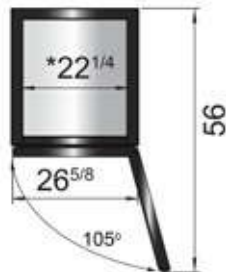

MCK-GD-SC1390F

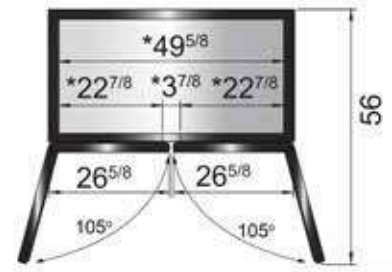

MCK-GD-SC2090F



Side Dimension



\* Interior Dimensions

Door Handle



Temp. Control



LED light



Door lock



Casters





Toll free +1 (833) 978 8833  
sales@mckequipment.ca  
Visit [mckonline.ca](http://mckonline.ca) for more details



# **Refrigerated Open Air Merchandisers**



Toll free +1 (833) 978 8833  
 sales@mckequipment.ca  
 Visit [mckonline.ca](http://mckonline.ca) for more details

Quality Kitchen  
 Equipment & Supplies



# Refrigerated Open Air Merchandisers

## FS-220L

- Brilliant Internal Lighting On Top And Under Each Shelf
- Stainless Steel Exterior
- Adjustable Stainless Steel Shelves
- Digital Temperature Control And Display
- 2 Sides Tempered Glass
- 4 Casters, 2 With Brakes
- Ventilated Cooling System
- Automatic Defrost
- With Curtain
- Condenser At Backside Maintenance Free
- Condensation Water Evaporated Automatically



**FS-220L**

*Don't forget to leave the unit some room to breathe!  
 Please clean the condenser frequently  
 to give the unit more fresh air.*





Toll free +1 (833) 978 8833  
 sales@mckequipment.ca  
 Visit [mckonline.ca](http://mckonline.ca) for more details



**SPECIFICATIONS**

Model	WIDTH (A)	DEPTH (B)	HEIGHT (C)	WEIGHT	CAPACITY	SHIPPING WIDTH	SHIPPING DEPTH	SHIPPING HEIGHT	SHIPPING WEIGHT	HP	AMPS
FS-220L	19.4"	26.7"	68.7"	209.4 LB	7.8 CU FT	22"	28.7"	75.9"	246.9 LB	3//4	11.8
	495 mm	680 mm	1745 mm	95 KG	220 L	560 mm	730 mm	1928 mm	112 KG		

VOLTAGE	NEMA PLUG	CORD LENGTH	REFRIGERANT	TEMPERATURE RANGE
110-120~	5-15P	≥1.8m	R290	0 to -12 C / 32 to -53 F

**PLAN VIEW**

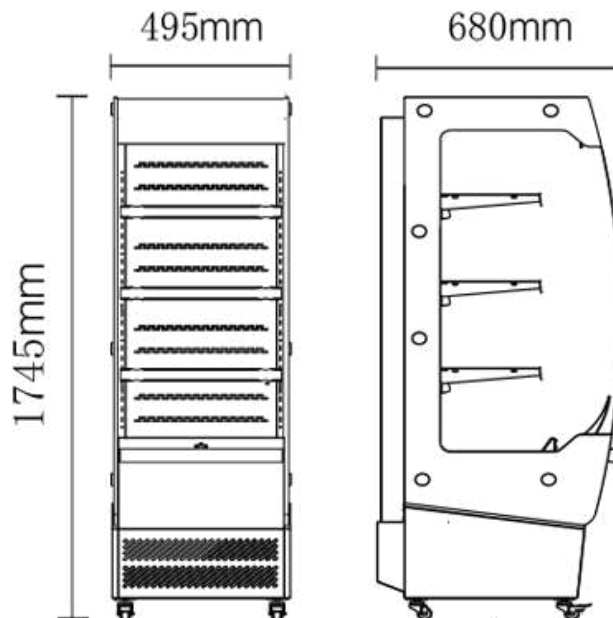



Toll free +1 (833) 978 8833  
 sales@mckequipment.ca  
 Visit [mckonline.ca](http://mckonline.ca) for more details

Quality Kitchen  
 Equipment & Supplies



# Refrigerated Open Air Merchandiser

**FS-900L | FS-1200L | FS-1500L | FS-1800L**

- Material: Stainless Steel
- Pull down curtain
- LED lighting under each shelf
- Adjustable shelves
- Digital temperature control & display
- 4 Casters
- Ventilated cooling system
- Automatic defrost



**FS-900L | FS-1200L | FS-1500L |  
 FS-1800L**

*Don't forget to leave the unit some room to breathe!  
 Please clean the condenser frequently  
 to give the unit more fresh air.*





**SPECIFICATIONS**

<b>Model Number</b>	<b>Description</b>	<b>Size (inches)</b>	<b>Net Weight (lbs)</b>	<b>Gross Weight (lbs)</b>
<b>FS-900L</b>	110V/60Hz, R290, 6 LED light, US plug	36.02 X 30.12 X 81.50	309	353
<b>FS-1200L</b>	110V/60Hz, R290, 6 LED light, US plug	47.83 × 30.12 × 81.50	419	474
<b>FS-1500L</b>	110V/60Hz, R290, 6 LED light, US plug	59.65 × 30.12 × 81.50	463	530
<b>FS-1800L</b>	110V/60Hz, R290, 6 LED light, US plug	71.46x30.12x81.5	530	617



Toll free +1 (833) 978 8833  
 sales@mckequipment.ca  
 Visit [mckonline.ca](http://mckonline.ca) for more details

Quality Kitchen  
 Equipment & Supplies



# Refrigerated Open Air Merchandiser

**OAM-30-HC | OAM-36-HC |  
 OAM-48-HC | OAM-72-HC**  
**Features:**

- Digital temperature control & display
- Efficient Cooling: Maintains ideal freshness and temperature with environmentally friendly R290 refrigerant
- Easy access for customers to grab products on the go, enhancing customer experience and satisfaction.
- Features modern cooling technology that minimizes energy use while maintaining optimal temperatures.
- Sturdy yet movable within commercial spaces.



**OAM-30-HC**

*Don't forget to leave the unit some room to breathe! Please clean the condenser frequently to give the unit more fresh air.*





Toll free +1 (833) 978 8833  
 sales@mckequipment.ca  
 Visit [mckonline.ca](http://mckonline.ca) for more details

# Quality Kitchen Equipment & Supplies



**OAM-36-HC**



**OAM-48-HC**



**OAM-72-HC**

*Don't forget to leave the unit some room to breathe! Please clean the condenser frequently to give the unit more fresh air.*





**SPECIFICATIONS**

<b>Model Number</b>	<b>Description</b>	<b>Compressor Hp</b>	<b>Size (inches)</b>	<b>Net Weight (lbs)</b>	<b>Gross Weight (lbs)</b>
<b>OAM-30-HC</b>	115 V/ 60 Hz/ 11 Amps / R290 Refrigerant/ 33 F and 44 F	1 - 1/2HP	29.9 x 27.8 x 82.8	290	334
<b>OAM-36-HC</b>	115 V/ 60 Hz/ 11 Amps / R290 Refrigerant/ 33 F and 44 F	1 - 1/2HP	36.0 x 27.8 x 82.8	312	356
<b>OAM-48-HC</b>	220 V/ 60 Hz/ 9.2 Amps / R290 Refrigerant/ 33 F and 44 F	2HP	48.0 x 27.8 x 82.8	436	488
<b>OAM-72-HC</b>	220 V/ 60 Hz/ 14.8 Amps / R290 Refrigerant/ 33 F and 44 F	3HP	71.9 x 27.8 x 82.8	614	687



Toll free +1 (833) 978 8833  
 sales@mckequipment.ca  
 Visit [mckonline.ca](http://mckonline.ca) for more details

Quality Kitchen  
 Equipment & Supplies



# Refrigerated Open Air Merchandiser

**OAM-30G-HC | OAM-36G-HC |  
 OAM-48G-HC | OAM-72G-HC**  
**Features:**



**OAM-30G-HC**

- Digital temperature control & display
- Efficient Cooling: Maintains ideal freshness and temperature with environmentally friendly R290 refrigerant
- Easy access for customers to grab products on the go, enhancing customer experience and satisfaction.
- Features modern cooling technology that minimizes energy use while maintaining optimal temperatures.
- Sturdy yet movable within commercial spaces.

*Don't forget to leave the unit some room to breathe! Please clean the condenser frequently to give the unit more fresh air.*





Toll free +1 (833) 978 8833  
 sales@mckequipment.ca  
 Visit [mckonline.ca](http://mckonline.ca) for more details

## Quality Kitchen Equipment & Supplies



**OAM-36G-HC**



**OAM-48G-HC**



**OAM-72G-HC**

*Don't forget to leave the unit some room to breathe! Please clean the condenser frequently to give the unit more fresh air.*





**SPECIFICATIONS**

<b>Model Number</b>	<b>Description</b>	<b>Compressor Hp</b>	<b>Size (inches)</b>	<b>Net Weight (lbs)</b>	<b>Gross Weight (lbs)</b>
<b>OAM-30G-HC</b>	115 V/ 60 Hz/ 11 Amps / R290 Refrigerant/ 33 F and 44 F	1 - 1/2HP	29.9 x 27.8 x 82.8	290	334
<b>OAM-36G-HC</b>	115 V/ 60 Hz/ 11 Amps / R290 Refrigerant/ 33 F and 44 F	1 - 1/2HP	36.0 x 27.8 x 82.8	312	356
<b>OAM-48G-HC</b>	220 V/ 60 Hz/ 9.2 Amps / R290 Refrigerant/ 33 F and 44 F	2HP	48.0 x 27.8 x 82.8	436	488
<b>OAM-72G-HC</b>	220 V/ 60 Hz/ 14.8 Amps / R290 Refrigerant/ 33 F and 44 F	3HP	71.9 x 27.8 x 82.8	614	687

# **BAR EQUIPMENT**

Back Bar Coolers

Back Bar Coolers with Glass Doors

Direct Draw Keg Coolers



Toll free +1 (833) 978 8833  
 sales@mckequipment.ca  
 Visit [mckonline.ca](http://mckonline.ca) for more details

Quality Kitchen  
 Equipment & Supplies



# Back Bar Coolers Solid Doors Stainless Steel

**MCK-UBB-24-48-HC-SS |**  
**MCK-UBB-24-60-HC-SS |**  
**MCK-UBB-24-72-HC-SS**  
**FEATURES**

- Stainless steel exterior and interior
- Carel digital controller, maintains temperatures between 33F - 40F
- Heavy duty Embraco compressor and R290 refrigerant
- Slide out compressor assembly for easy maintenance
- Recessed door handle(s) and interior light(s)
- Magnetic door gasket(s) standard for positive door seal
- Pre-installed epoxy coated shelves
- Pre-installed casters



**MCK-UBB-24-48-HC-SS**



**MCK-UBB-24-60-HC-SS**



**MCK-UBB-24-72-HC-SS**

*Don't forget to leave the unit some room to breathe!  
 Please clean the condenser frequently  
 to give the unit more fresh air.*





Toll free +1 (833) 978 8833  
 sales@mckequipment.ca  
 Visit [mckonline.ca](http://mckonline.ca) for more details

Quality Kitchen  
 Equipment & Supplies



### SPECIFICATIONS

Model	Door	Capacity (Cu. Ft.)	Shelves	Casters (Inch)	Rated Current (A)	Voltage (V/Hz/Ph)	HP	Refrigerant	Exterior Dimensions	Net Weight (lbs)	Gross Weight (lbs)
MCK-UBB-24-48-HC-SS	2	11.5	4	2	2.3	115/60/1	1/7	R290	48 x 24 1/2 x 40 1/8	315	343
MCK-UBB-24-60-HC-SS	2	15	4	2				R290	57 3/4 x 24 1/2 x 40 1/8	380	414
MCK-UBB-24-72-HC-SS	3	18.6	6	2				R290	68 x 24 1/2 x 40 1/8	410	447

### PLAN VIEW

MCK-UBB-24-48-HC-SS    MCK-UBB-24-60-HC-SS    MCK-UBB-24-72-HC-SS

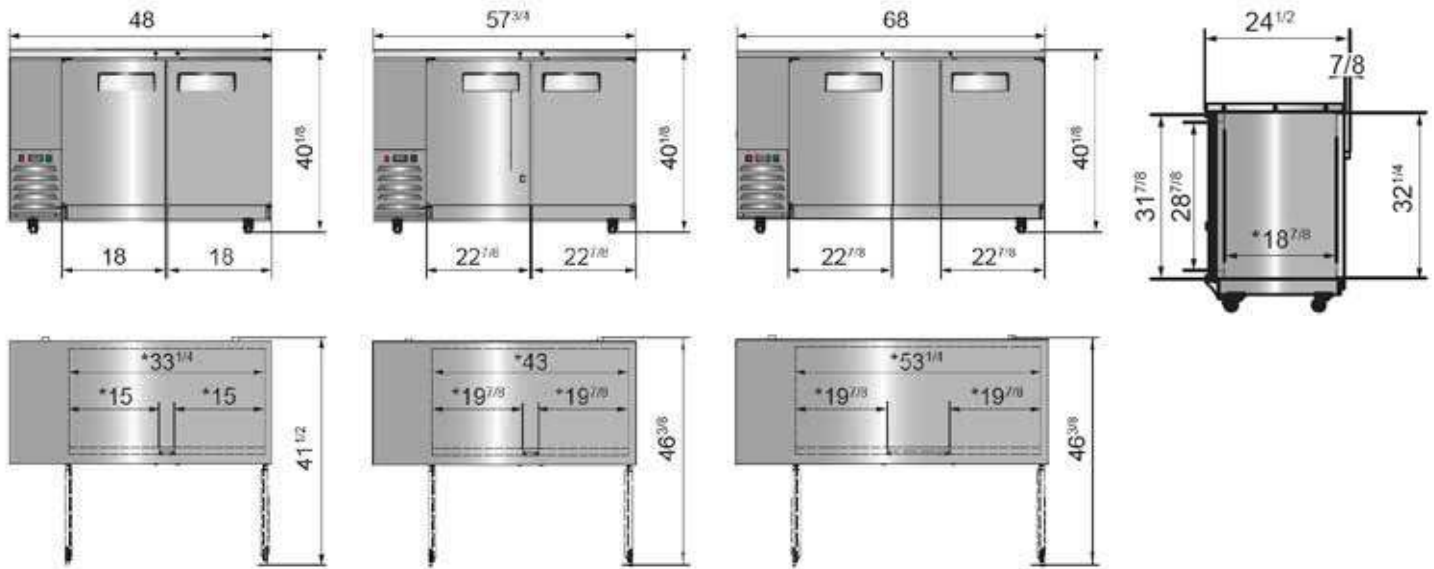

Casters



Compressor



Shelve



Door Lock



Temp. Control





Toll free +1 (833) 978 8833  
 sales@mckequipment.ca  
 Visit [mckonline.ca](http://mckonline.ca) for more details

Quality Kitchen  
 Equipment & Supplies



# Back Bar Coolers Solid Doors

**MCK-UBB-24-48-HC |**  
**MCK-UBB-24-60-HC |**  
**MCK-UBB-24-72-HC**

## FEATURES

- Carel digital controller, maintains temperatures between 33°F– 40°F
- Heavy duty Embraco compressor and R290 refrigerant
- Slide out compressor assembly for easy maintenance
- Recessed door handle(s) and interior light(s)
- Magnetic door gasket(s) standard for positive door seal
- Pre-installed epoxy coated shelves
- Pre-installed casters



**MCK-UBB-24-48-HC**



**MCK-UBB-24-60-HC**



**MCK-UBB-24-72-HC**

*Don't forget to leave the unit some room to breathe!  
 Please clean the condenser frequently  
 to give the unit more fresh air.*





Toll free +1 (833) 978 8833  
 sales@mckequipment.ca  
 Visit [mckonline.ca](http://mckonline.ca) for more details

Quality Kitchen  
 Equipment & Supplies



## SPECIFICATIONS

Model	Door	Capacity (Cu. Ft.)	Shelves	Casters (Inch)	Rated Current (A)	Voltage (V/Hz/Ph)	HP	Refrigerant	Exterior Dimensions	Net Weight (lbs)	Gross Weight (lbs)
MCK-UBB-24-48-HC	2	11.5	4	2	2.3	115/60/1	1/7	R290	48 x 24 1/2 x 40 1/8	315	343
MCK-UBB-24-60-HC	2	15	4	2				R290	57 3/4 x 24 1/2 x 40 1/8	380	414
MCK-UBB-24-72-HC	3	18.6	6	2				R290	68 x 24 1/2 x 40 1/8	410	447

## PLAN VIEW

MCK-UBB-24-48-HC

MCK-UBB-24-60-HC

MCK-UBB-24-72-HC

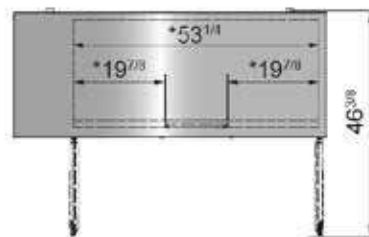
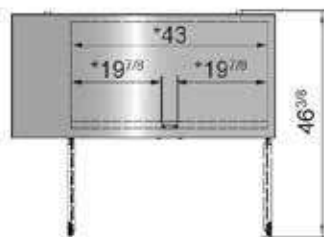
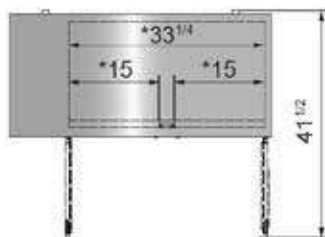
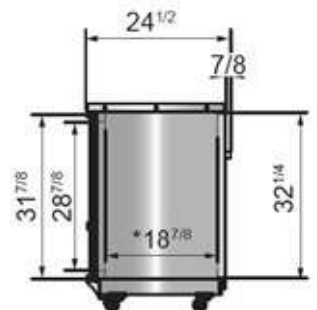
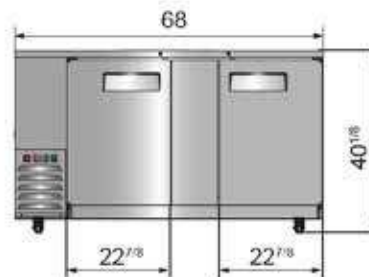

Casters



Compressor



Shelve



Door Lock



Temp. Control





Toll free +1 (833) 978 8833  
 sales@mckequipment.ca  
 Visit [mckonline.ca](http://mckonline.ca) for more details

Quality Kitchen  
 Equipment & Supplies



# Back Bar Coolers Glass Doors Stainless Steel

**MCK-UBB-24-48GSS-HC-SS |**  
**MCK-UBB-24-60GSS-HC-SS |**  
**MCK-UBB-24-72GSS-HC-SS**

## FEATURES

- Stainless steel exterior & interior
- Digital controller, maintains temperatures between 32°F– 41°F
- Heavy duty Embraco compressor and R290 refrigerant
- Slide out compressor assembly for easy maintenance
- Recessed door handle(s) and interior light(s)
- Magnetic door gasket(s) standard for positive door seal
- Pre-installed epoxy coated shelves
- Pre-installed casters



**MCK-UBB-24-48G-HC-SS**



**MCK-UBB-24-60G-HC-SS**



**MCK-UBB-24-72G-HC-SS**

*Don't forget to leave the unit some room to breathe!  
 Please clean the condenser frequently  
 to give the unit more fresh air.*





### SPECIFICATIONS

Model	Door	Capacity (Cu. Ft. / Lbs)	Shelves	Casters (Inch)	Rated Current (A)	Voltage (V/Hz/Ph)	HP	Refrigerant	Exterior Dimensions	Net Weight (lbs)	Gross Weight (lbs)
MCK-UBB-24-48G-HC-SS	2	11.8 / 335	4	2	2.8	115/60/1	1/5	R290	48 x 24 3/8 x 35 5/8	315	343
MCK-UBB-24-60G-HC-SS	2	15.8 / 446	4	2	2.8	115/60/1	1/5	R290	60 3/4 x 24 3/8 x 35 5/8	380	414
MCK-UBB-24-72G-HC-SS	3	19.5 / 556	6	2	3.96	115/60/1	1/4+	R290	72 3/4 x 24 3/8 x 35 5/8	410	447

### PLAN VIEW

MCK-UBB-24-48G-HC-SS

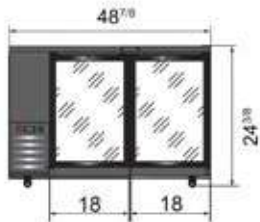

MCK-UBB-24-60G-HC-SS

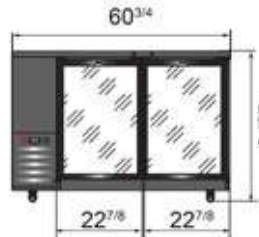

MCK-UBB-24-72G-HC-SS

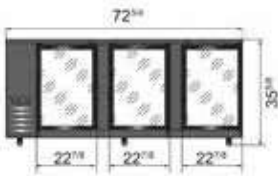

Side Dimensions



Casters



Compressor



Shelve



Door Lock



Temp. Control





Toll free +1 (833) 978 8833  
 sales@mckequipment.ca  
 Visit [mckonline.ca](http://mckonline.ca) for more details

Quality Kitchen  
 Equipment & Supplies



# Back Bar Coolers Glass Doors

**MCK-UBB-24-48G-HC |**

**MCK-UBB-24-60G-HC |**

**MCK-UBB-24-72G-HC**

## FEATURES

- Stainless steel counter
- Digital controller, maintains temperatures between 32°F– 41°F
- Heavy duty Embraco compressor and R290 refrigerant
- Slide out compressor assembly for easy maintenance
- Recessed door handle(s) and interior light(s)
- Magnetic door gasket(s) standard for positive door seal
- Pre-installed epoxy coated shelves
- Pre-installed casters



**MCK-UBB-24-48G-HC**



**MCK-UBB-24-60G-HC**



**MCK-UBB-24-72G-HC**

*Don't forget to leave the unit some room to breathe!  
 Please clean the condenser frequently  
 to give the unit more fresh air.*





Toll free +1 (833) 978 8833  
 sales@mckequipment.ca  
 Visit [mckonline.ca](http://mckonline.ca) for more details

Quality Kitchen  
 Equipment & Supplies



## SPECIFICATIONS

Model	Door	Capacity (Cu. Ft. / Lbs)	Shelves	Casters (Inch)	Rated Current (A)	Voltage (V/Hz/Ph)	HP	Refrigerant	Exterior Dimensions	Net Weight (lbs)	Gross Weight (lbs)
MCK-UBB-24-48G-HC	2	11.8 / 335	4	2	2.8	115/60/1	1/5	R290	48 x 24 3/8 x 35 5/8	315	343
MCK-UBB-24-60G-HC	2	15.8 / 446	4	2	2.8	115/60/1	1/5	R290	60 3/4 x 24 3/8 x 35 5/8	380	414
MCK-UBB-24-72G-HC	3	19.5 / 556	6	2	3.96	115/60/1	1/4+	R290	72 3/4 x 24 3/8 x 35 5/8	410	447

## PLAN VIEW

MCK-UBB-24-48G-HC

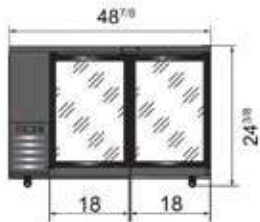

MCK-UBB-24-60G-HC

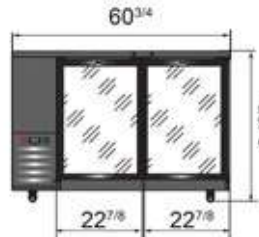

MCK-UBB-24-72G-HC

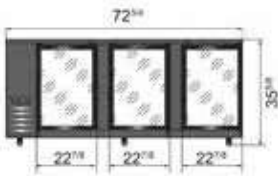

Side Dimensions



Casters



Compressor



Shelve



Door Lock



Temp. Control





Toll free +1 (833) 978 8833  
 sales@mckequipment.ca  
 Visit [mckonline.ca](http://mckonline.ca) for more details

Quality Kitchen  
 Equipment & Supplies



# Back Bar Coolers Glass Sliding Doors Stainless Steel

**MCK-UBB-24-48-G-Y-HC-SS |**  
**MCK-UBB-24-60-G-Y-HC-SS |**  
**MCK-UBB-24-72-G-Y-HC-SS**

## FEATURES

- Stainless steel exterior & interior
- Digital controller, maintains temperatures between 32°F- 41°F
- Heavy duty Embraco compressor and R290 refrigerant
- Slide out compressor assembly for easy maintenance
- Recessed door handle(s) and interior light(s)
- Magnetic door gasket(s) standard for positive door seal
- Pre-installed epoxy coated shelves
- Pre-installed casters



**MCK-UBB-24-48-G-Y-HC-SS**



**MCK-UBB-24-60-G-Y-HC-SS**



**MCK-UBB-24-72-G-Y-HC-SS**

*Don't forget to leave the unit some room to breathe!  
 Please clean the condenser frequently  
 to give the unit more fresh air.*





### SPECIFICATIONS

Model	Door	Capacity (Cu. Ft. / Lbs)	Shelves	Casters (Inch)	Rated Current (A)	Voltage (V/Hz/Ph)	HP	Refrigerant	Exterior Dimensions	Net Weight (lbs)	Gross Weight (lbs)
MCK-UBB-24-48-G-Y-HC-SS	2	11.8 / 335	4	2	2.8	115/60/1	1/5	R290	48 x 24 3/8 x 35 5/8	315	343
MCK-UBB-24-60-G-Y-HC-SS	2	15.8 / 446	4	2	2.8	115/60/1	1/5	R290	60 3/4 x 24 3/8 x 35 5/8	380	414
MCK-UBB-24-72-G-Y-HC-SS	3	19.5 / 556	6	2	3.96	115/60/1	1/4+	R290	72 3/4 x 24 3/8 x 35 5/8	410	447

### PLAN VIEW

MCK-UBB-24-60-G-Y-HC

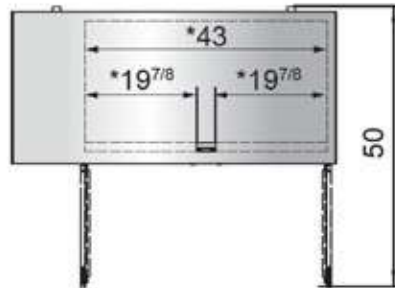
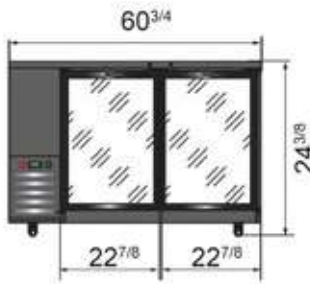

MCK-UBB-24-72-G-Y-HC

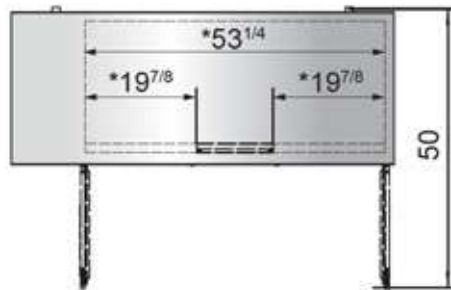
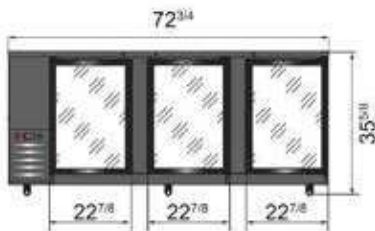

Side Dimensions

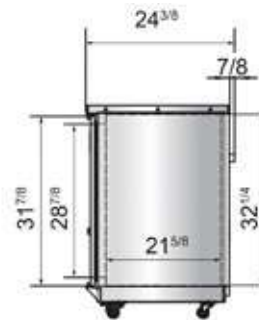

Casters



Compressor



Shelve



Door Lock



Temp. Control





Toll free +1 (833) 978 8833  
 sales@mckequipment.ca  
 Visit [mckonline.ca](http://mckonline.ca) for more details

Quality Kitchen  
 Equipment & Supplies



# Back Bar Coolers Glass Sliding Doors

**MCK-UBB-24-48-G-Y-HC |**  
**MCK-UBB-24-60-G-Y-HC |**  
**MCK-UBB-24-72-G-Y-HC**

## FEATURES

- Stainless steel counter
- Digital controller, maintains temperatures between 32°F– 41°F
- Heavy duty Embraco compressor and R290 refrigerant
- Slide out compressor assembly for easy maintenance
- Recessed door handle(s) and interior light(s)
- Magnetic door gasket(s) standard for positive door seal
- Pre-installed epoxy coated shelves
- Pre-installed casters



**MCK-UBB-24-48-G-Y-HC**



**MCK-UBB-24-60-G-Y-HC**



**MCK-UBB-24-72-G-Y-HC**

*Don't forget to leave the unit some room to breathe!  
 Please clean the condenser frequently  
 to give the unit more fresh air.*





Toll free +1 (833) 978 8833  
 sales@mckequipment.ca  
 Visit [mckonline.ca](http://mckonline.ca) for more details

Quality Kitchen  
 Equipment & Supplies



## SPECIFICATIONS

Model	Door	Capacity (Cu. Ft. / Lbs)	Shelves	Casters (Inch)	Rated Current (A)	Voltage (V/Hz/Ph)	HP	Refrigerant	Exterior Dimensions	Net Weight (lbs)	Gross Weight (lbs)
MCK-UBB-24-48-G-Y-HC	2	11.8 / 335	4	2	2.8	115/60/1	1/5	R290	48 × 24 3/8 × 35 5/8	315	343
MCK-UBB-24-60-G-Y-HC	2	15.8 / 446	4	2	2.8	115/60/1	1/5	R290	60 3/4 × 24 3/8 × 35 5/8	380	414
MCK-UBB-24-72-G-Y-HC	3	19.5 / 556	6	2	3.96	115/60/1	1/4+	R290	72 3/4 × 24 3/8 × 35 5/8	410	447

## PLAN VIEW

MCK-UBB-24-60-G-Y-HC

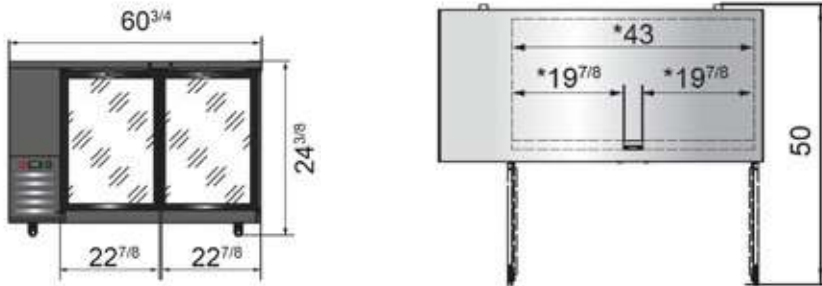

MCK-UBB-24-72-G-Y-HC

Les dimensions latérales

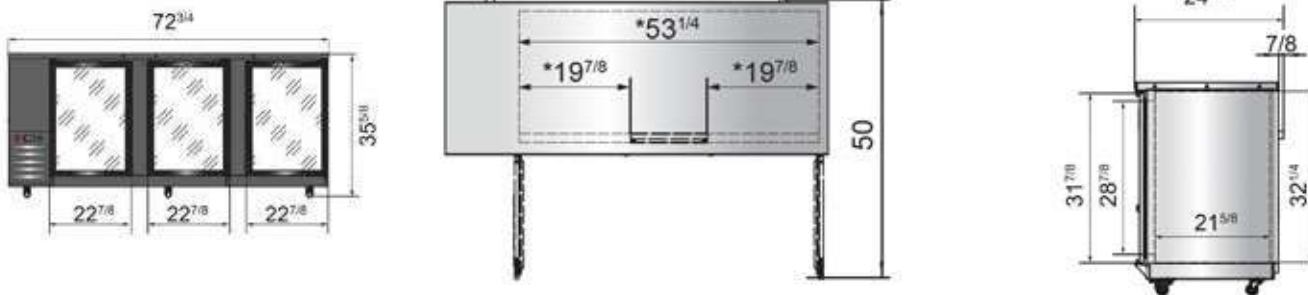

Casters

Compressor

Shelve

Door Lock

Temp. Control





Toll free +1 (833) 978 8833  
 sales@mckequipment.ca  
 Visit [mckonline.ca](http://mckonline.ca) for more details

Quality Kitchen  
 Equipment & Supplies



# Direct Draw Keg Cooler

MCK-UDD-24-48SS-HC | MCK-UDD-24-60SS-HC |  
 MCK-UDD-24-72SS-HC

## FEATURES

- Stainless steel exterior & interior
- Digital controller
- Temperatures between 33 degrees F - 40 degrees F
- Heavy duty Embraco compressor with environmentally friendly R290 refrigerant
- Slide out compressor assembly
- Stainless steel drip tray(s)
- Recessed door handle(s)
- Dual tap tower(s) standard
- Interior light(s)
- Magnetic door gasket(s) standard for positive door seal
- Manifold and ball taps included
- Door lock(s) standard
- Pre-installed casters



MCK-UDD-24-48SS-HC



MCK-UDD-24-60SS-HC



MCK-UDD-24-72SS-HC

*Don't forget to leave the unit some room to breathe!  
 Please clean the condenser frequently  
 to give the unit more fresh air.*





### SPECIFICATIONS

Model	Door	Shelves	Tap Tower	Capacity (Cu. Ft./ Barrels)	Casters (Inch)	Rated Current (A)	Voltage (V/Hz/Ph)	HP	Refrigerant	Exterior Dimensions	Net Weight (lbs)	Gross Weight (lbs)
MCK-UDD-24-48SS-HC	1	4	1 Single Tower	11.8 / 2*1/2	2	3	115/60/1	1/5	R290	48 7/8 x 24 3/8 x 35 5/8	132	188
MCK-UDD-24-60SS-HC	2	4	1 Single Tower	15.8 / 2*1/2	2	3	115/60/1	1/5	R290	60 3/4 x 24 3/8 x 35 5/8	209	243
MCK-UDD-24-72SS-HC	3	6	2 Single Tower	19.6 / 3*1/2	2	4	115/60/1	1/4+	R290	72 3/4 x 24 3/8 x 35 5/8	234	291

### PLAN VIEW

MCK-UDD-24-48SS-HC

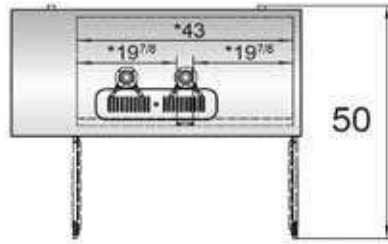

MCK-UDD-24-60SS-HC

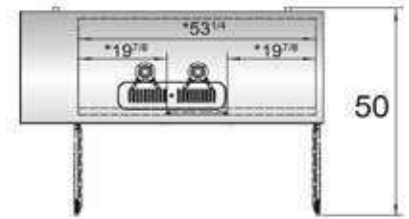
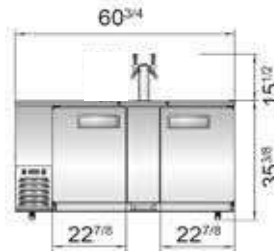

MCK-UDD-24-72SS-HC

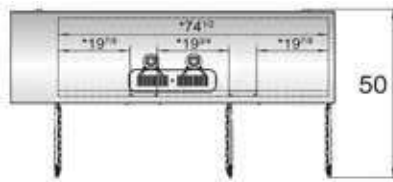
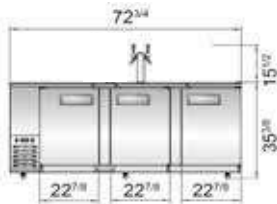

Side Dimensions

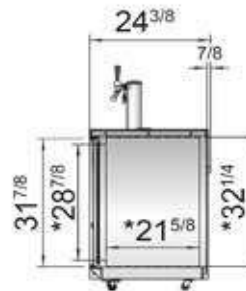

Casters



Tap Tower



Dirp tray



Door Lock



Temp. Control





Toll free +1 (833) 978 8833  
 sales@mckequipment.ca  
 Visit [mckonline.ca](http://mckonline.ca) for more details

Quality Kitchen  
 Equipment & Supplies



# Direct Draw Keg Cooler

MCK-UDD-1-HC | MCK-UDD-2-HC |  
 MCK-UDD-3-HC | MCK-UDD-4-HC

## FEATURES

- Stainless steel and Black exterior & interior
- Digital controller
- Temperatures between 33 degrees F - 40 degrees F
- Heavy duty Embraco compressor with environmentally friendly R290 refrigerant
- Slide out compressor assembly
- Stainless steel drip tray(s)
- Recessed door handle(s)
- Dual tap tower(s) standard
- Interior light(s)
- Magnetic door gasket(s) standard for positive door seal
- Manifold and ball taps included
- Door lock(s) standard
- Pre-installed casters



MCK-UDD-1-HC



MCK-UDD-2-HC



MCK-UDD-4-HC



MCK-UDD-3-HC

**Don't forget to leave the unit some room to breathe!**  
 Please clean the condenser frequently  
 to give the unit more fresh air.





### SPECIFICATIONS

Model	Door	Shelves	Tap Tower	Capacity (Cu. Ft. / Barrels)	Casters (Inch)	Rated Current (A)	Voltage (V/Hz/Ph)	HP	Refrigerant	Exterior Dimensions	Net Weight (lbs)	Gross Weight (lbs)
MCK-UDD-1-HC	1	2	1 Single Tower	6.5 / 2 x 1/2	2	1.92	115/60/1	1/6	R290	23x31 1/10x31 1/10	132	188
MCK-UDD-2-HC	2	4	1 Single Tower	19 / 2 x 1/2	2	2.88	115/60/1	1/5	R290	58 7/8x27 x35 5/8	209	243
MCK-UDD-3-HC	2	4	2 Single Tower	23.3 / 3 x 1/2	2	3.6	115/60/1	1/5	R290	59 1/8 x27 x35 5/8	234	291
MCK-UDD-4-HC	3	6	2 Single Tower	32 / 4 x 1/2	2	4.7	115/60/1	1/4+	R290	69 1/8 x27 x35 5/8	282	357

### PLAN VIEW

MCK-UDD-1-HC



MCK-UDD-2-HC

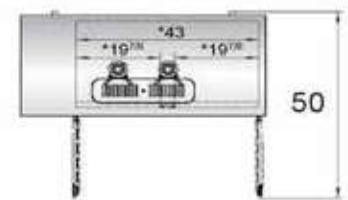
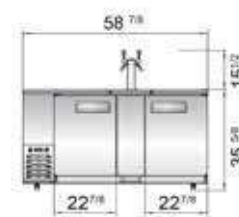
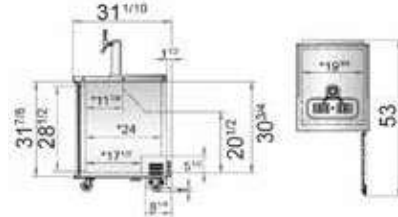

MCK-UDD-3-HC

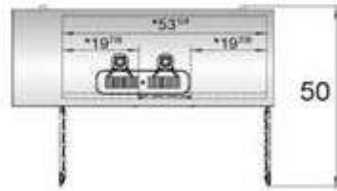
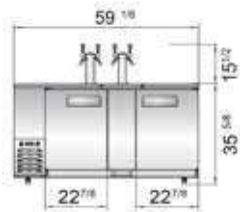

MCK-UDD-4-HC

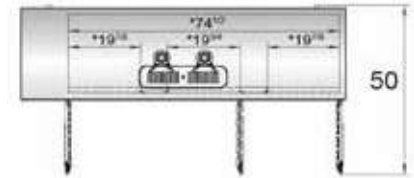
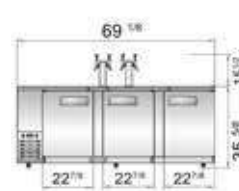

Side Dimensions

Casters



Tap Tower



Dirp tray



Door Lock



Temp. Control





Toll free +1 (833) 978 8833  
sales@mckequipment.ca  
Visit [mckonline.ca](http://mckonline.ca) for more details



# **REFRIGERATED SANDWICH PREP. TABLES**

Standard Top Sandwich Prep Tables  
Mega Top Sandwich Prep Tables



Toll free +1 (833) 978 8833  
 sales@mckequipment.ca  
 Visit [mckonline.ca](http://mckonline.ca) for more details

Quality Kitchen  
 Equipment & Supplies



# Standard Top Sandwich / Salad Prep Tables

MCK-TSSU29T | MCK-TSSU48T | MCK-TSSU60T |  
 MCK-TSSU72T

## FEATURES

- Stainless steel exterior & interior
  - Rear mount compressor with environmentally friendly R290 refrigerant
  - Dixell digital controller
  - Maintains temperatures between 33°F - 40°F
  - Pre-installed 4" deep stainless steel pans
  - 10" cutting board
  - Automatic Defrosting with ventilated cooling system
  - Recessed door handle(s)
  - Self-closing door(s) with stay open feature
- Magnetic door gasket(s) standard for positive door seal  
 One(1) pre-installed shelf per section  
 Pre-installed casters



MCK-TSSU29T



MCK-TSSU48T



MCK-TSSU60T



MCK-TSSU72T

*Don't forget to leave the unit some room to breathe!  
 Please clean the condenser frequently  
 to give the unit more fresh air.*





Toll free +1 (833) 978 8833  
 sales@mckequipment.ca  
 Visit [mckonline.ca](http://mckonline.ca) for more details

Quality Kitchen  
 Equipment & Supplies



## SPECIFICATIONS

Model	Door	Capacity (Cu. Ft.)	Shelves	Casters (Inch)	Rated Current (A)	Voltage (V/Hz/Ph)	HP	Refrigerant	Exterior Dimensions	Net Weight (lbs)	Gross Weight (lbs)
MCK-TSSU29T	1	7.59	1	5	3.6	115/60/1	1/7	R290	29 x 31 1/10 x 45 2/5	150	185
MCK-TSSU48T	2	13.8	2	5	4.3	115/60/1	1/7	R290	48 2/5 x 31 7/10 x 45 2/5	256	304
MCK-TSSU60T	2	17.8	2	5	5.6	115/60/1	1/5	R290	61 1/5 x 31 7/10 x 45 2/5	298	355
MCK-TSSU72T	3	21.22	3	5	5.6	115/60/1	1/5	R290	72 x 31 7/10 x 45 2/5	340	404

## PLAN VIEW

MCK-TSSU29T

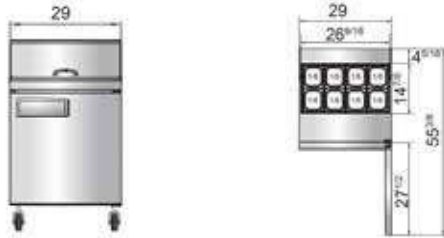

MCK-TSSU48T



MCK-TSSU60T

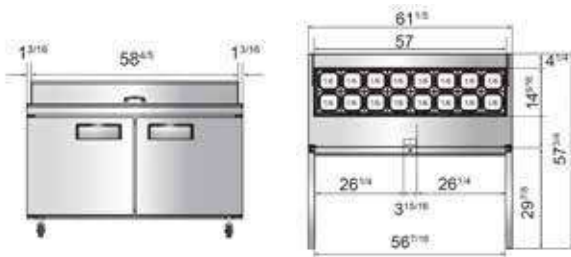

MCK-TSSU72T

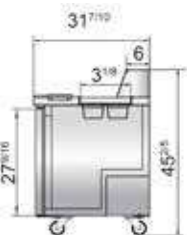

Side Dimensions

Casters



Top Handle



Shelve



Pan



Temp. Control





Toll free +1 (833) 978 8833  
 sales@mckequipment.ca  
 Visit [mckonline.ca](http://mckonline.ca) for more details

Quality Kitchen  
 Equipment & Supplies



# Standard Top Sandwich / Salad Prep Tables

MCK-SCL1-27-HC | MCK-SCL2-36-HC | MCK-SCL2-48-HC | MCK-SCL2-60-HC | MCK-SCL3-72-HC

## FEATURES

- Stainless steel exterior & interior
- Rear mount compressor with environmentally friendly R290 refrigerant
- Dixell digital controller
- Maintains temperatures between 33°F - 40°F
- Pre-installed 4" deep stainless steel pans
- 10" cutting board
- Automatic Defrosting with ventilated cooling system
- Recessed door handle(s)
- Self-closing door(s) with stay open feature
- Magnetic door gasket(s) standard for positive door seal
- One(1) pre-installed shelf per section
- Pre-installed casters



MCK-SCL1-27-HC



MCK-SCL2-36-HC



MCK-SCL2-48-HC



MCK-SCL3-72-HC



MCK-SCL2-60-HC

*Don't forget to leave the unit some room to breathe!  
 Please clean the condenser frequently  
 to give the unit more fresh air.*





Toll free +1 (833) 978 8833  
 sales@mckequipment.ca  
 Visit [mckonline.ca](http://mckonline.ca) for more details



### SPECIFICATIONS

Model	Door	Capacity (Cu. Ft.)	Shelves	Casters (Inch)	Rated Current (A)	Voltage (V/Hz/Ph)	HP	Refrigerant	Exterior Dimensions	Net Weight (lbs)	Gross Weight (lbs)
MCK-SCL1-27-HC	1	5.7	1	5	2.88	115/60/1	1/5	R290	27 1/2 x 34 x 45 9/10	176	231
MCK-SCL2-36-HC	2	7.6	2	5	3.24	115/60/1	1/5	R290	36 1/4 x 34 x 45 9/10	253	298
MCK-SCL2-48-HC	2	9.5	2	5	4.56	115/60/1	1/4+	R290	46 7/8 x 34 x 45 9/10	284	340
MCK-SCL2-60-HC	2	15	2	5	4.8	115/60/1	1/4+	R290	60 1/5 x 34 x 45 9/10	331	401
MCK-SCL3-72-HC	3	15.5	3	5	8.9	115/60/1	3/4	R290	70 2/5 x 34 x 45 9/10	344	408

### PLAN VIEW

MCK-SCL1-27-HC



MCK-SCL2-36-HC

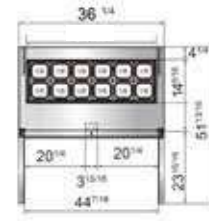

MCK-SCL2-48-HC

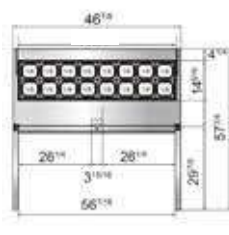

MCK-SCL2-60-HC

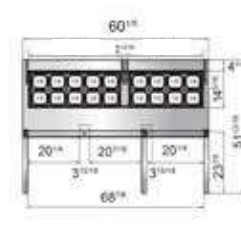

MCK-SCL2-72-HC

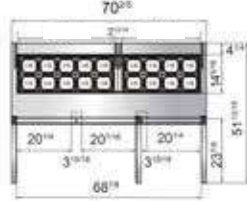

Side Dimensions

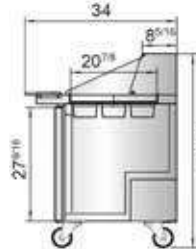

Casters



Top Handle



Shelve



Pan



Temp. Control





Toll free +1 (833) 978 8833  
 sales@mckequipment.ca  
 Visit [mckonline.ca](http://mckonline.ca) for more details

Quality Kitchen  
 Equipment & Supplies



# Mega Top Sandwich / Salad Prep Tables

MCK-TSSU29T-M | MCK-TSSU48T-M |  
 MCK-TSSU60T-M | MCK-TSSU72T-M

## FEATURES

- Stainless steel exterior & interior
  - Rear mount compressor with environmentally friendly R290 refrigerant
  - Dixell digital controller
  - Maintains temperatures between 33°F - 40°F
  - Pre-installed 4" deep stainless steel pans
  - 10" cutting board
  - Automatic Defrosting with ventilated cooling system
  - Recessed door handle(s)
  - Self-closing door(s) with stay open feature
- Magnetic door gasket(s) standard for positive door seal  
 One(1) pre-installed shelf per section  
 Pre-installed casters



MCK-TSSU29T-M



MCK-TSSU48T-M



MCK-TSSU60T-M



MCK-TSSU72T-M

*Don't forget to leave the unit some room to breathe!  
 Please clean the condenser frequently  
 to give the unit more fresh air.*





Toll free +1 (833) 978 8833  
 sales@mckequipment.ca  
 Visit [mckonline.ca](http://mckonline.ca) for more details

Quality Kitchen  
 Equipment & Supplies



## SPECIFICATIONS

Model	Door	Capacity (Cu. Ft.)	Shelves	Casters (Inch)	Rated Current (A)	Voltage (V/Hz/Ph)	HP	Refrigerant	Exterior Dimensions	Net Weight (lbs)	Gross Weight (lbs)
MCK-TSSU29T-M	1	7.59	1	5	3.6	115/60/1	1/7	R290	29 x 31 1/10 x 45 2/5	152	187
MCK-TSSU48T-M	2	13.8	2	5	4.3	115/60/1	1/7	R290	48 2/5 x 31 7/10 x 45 2/5	259	307
MCK-TSSU60T-M	2	17.8	2	5	5.6	115/60/1	1/5	R290	61 1/2 x 31 7/10 x 45 2/5	303	358
MCK-TSSU72T-M	3	21.22	3	5	5.6	115/60/1	1/5	R290	72 x 31 7/10 x 45 2/5	344	408

## PLAN VIEW

MCK-TSSU29T

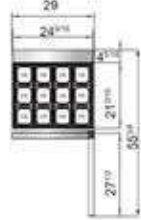

MCK-TSSU48T

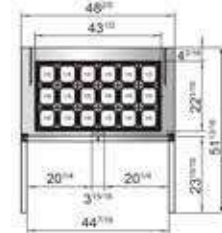

MCK-TSSU60T

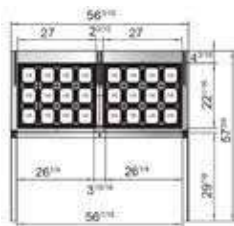

MCK-TSSU72T

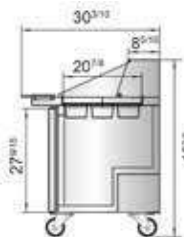
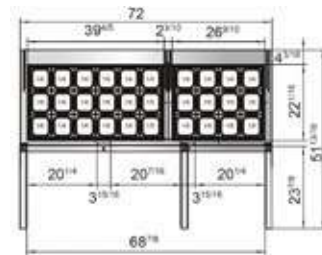

Side Dimensions

Casters



Top Handle



Shelve



Pan



Temp. Control





Toll free +1 (833) 978 8833  
 sales@mckequipment.ca  
 Visit [mckonline.ca](http://mckonline.ca) for more details

Quality Kitchen  
 Equipment & Supplies



# Mega Top Sandwich/Salad Prep Tables

MCK-SCLM1-27-HC | MCK-SCLM2-36-HC |  
 MCK-SCLM2-48-HC | MCK-SCLM2-60-HC |  
 MCK-SCLM3-72-HC

## FEATURES

- Stainless steel exterior & interior
- Rear mount compressor with environmentally friendly R290 refrigerant
- Dixell digital controller
- Maintains temperatures between 33°F - 40°F
- Pre-installed 4" deep stainless steel pans
- 10" cutting board
- Automatic Defrosting with ventilated cooling system
- Recessed door handle(s)
- Self-closing door(s) with stay open feature
- Magnetic door gasket(s) standard for positive door seal
- One(1) pre-installed shelf per section
- Pre-installed casters



MCK-SCLM1-27-HC



MCK-SCLM2-36-HC



MCK-SCLM2-48-HC



MCK-SCLM3-72-HC



MCK-SCLM2-60-HC

**Don't forget to leave the unit some room to breathe!**  
 Please clean the condenser frequently  
 to give the unit more fresh air.





### SPECIFICATIONS

Model	Door	Capacity (Cu. Ft.)	Shelves	Casters (Inch)	Rated Current (A)	Voltage (V/Hz/Ph)	HP Refrigerant	Exterior Dimensions	Net Weight (lbs)	Gross Weight (lbs)	
MCK-SCLM1-27-HC	1	5.7	1	5	2.88	115/60/1	R290	27.5 x 34 x 45.9	170	212	
MCK-SCLM2-36-HC	2	7.6	2		3.24			1/5	36.2 x 34 x 45.9	243	293
MCK-SCLM2-48-HC	2	9.5	2		4.56			1/4+	46.8 x 34 x 45.9	284	340
MCK-SCLM2-60-HC	2	15	2		4.8			1/4+	60.2 x 34 x 45.9	331	401
MCK-SCLM3-72-HC	3	15.5	3		8.9			3/4	70.4 x 34 x 45.9	344	408

### PLAN VIEW



MCK-SCLM1-27-HC

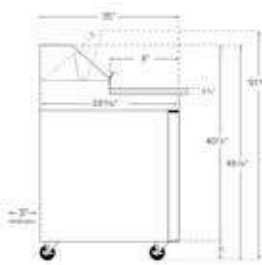

MCK-SCLM2-36-HC

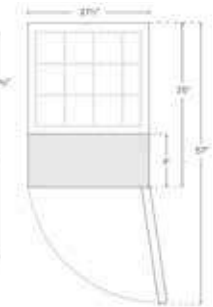

MCK-SCLM2-48-HC

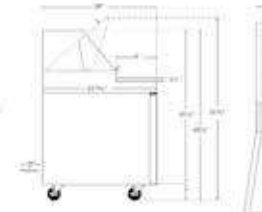

MCK-SCLM2-60-HC

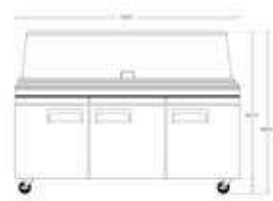
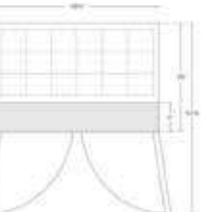

MCK-SCLM3-72-HC

Casters



Top Handle



Shelves



Pan



Temp. Control





Toll free +1 (833) 978 8833  
sales@mckequipment.ca  
Visit [mckonline.ca](http://mckonline.ca) for more details



# **REFRIGERATED PIZZA PREP. TABLES**

44",67"or94"  
Pizza Preparation Table



Toll free +1 (833) 978 8833  
 sales@mckequipment.ca  
 Visit [mckonline.ca](http://mckonline.ca) for more details

Quality Kitchen  
 Equipment & Supplies



# Refrigerated Pizza Prep Tables

MCK-GD-TPP-47 | MCK-GD-TPP-67 |  
 MCK-GD-TPP-94

## FEATURES

- Stainless steel exterior & interior
- Electronic Temperature Controller
- Maintains temperatures between 34 degrees F to 40 degrees F
- Stainless steel 1/3 size pans included
- 19-1/4 inch cutting board standard
- Automatic defrosting with ventilated cooling system
- Self-closing door(s) with stay open feature
- Recessed door handle(s)
- Magnetic door gasket(s) standard for positive door seal
- Two (2) pre-installed shelves per section
- Side mount compressor with environmentally friendly R290 refrigerant
- Pre-installed casters



MCK-GD-TPP-47



MCK-GD-TPP-67



MCK-GD-TPP-94

*Don't forget to leave the unit some room to breathe!  
 Please clean the condenser frequently  
 to give the unit more fresh air.*





## SPECIFICATIONS

Model	Door	Capacity (Cu. Ft.)	Shelves	Casters (Inch)	Rated Current (A)	Voltage (V/Hz/Ph)	HP	Refrigerant	Exterior Dimensions	Net Weight (lbs)	Gross Weight (lbs)
MCK-GD-TPP-47	1	11	2	5	4	115/60/1	1/4	R290	47 x 34 3/5 x 42	238	295
MCK-GD-TPP-67	2	21	4	5	5.8	115/60/1	1/2	R290	71 x 34 3/5 x 42	335	406
MCK-GD-TPP-94	3	31	6	5	5.8	115/60/1	3/4	R290	94 x 34 3/5 x 42	428	527

## PLAN VIEW

MCK-GD-TPP-47

MCK-GD-TPP-67

MCK-GD-TPP-94

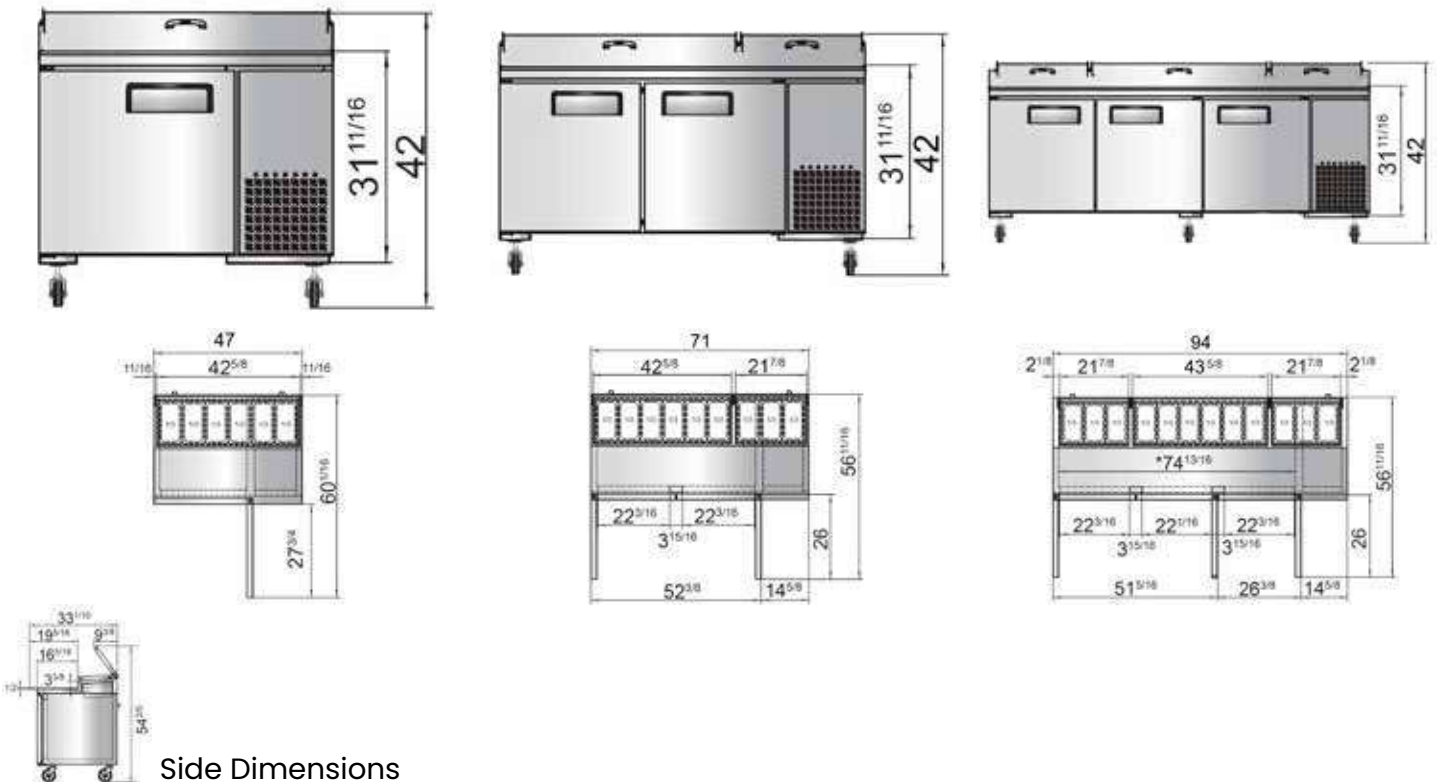

Side Dimensions

Casters



Epoxy shelves

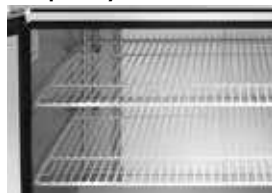

SS Pan



Control





Toll free +1 (833) 978 8833  
 sales@mckequipment.ca  
 Visit [mckonline.ca](http://mckonline.ca) for more details

Quality Kitchen  
 Equipment & Supplies



# Refrigerated Pizza Prep Tables

MCK-PICL1-HC | MCK-PICL2-HC | MCK-PICL3-HC

## FEATURES

- Stainless steel exterior & interior
- Electronic Temperature Controller
- Maintains temperatures between 34 degrees F to 40 degrees F
- Stainless steel 1/3 size pans included
- 19-1/4" cutting board standard
- Automatic defrosting with ventilated cooling system
- Self-closing door(s) with stay open feature
- Recessed door handle(s)
- Magnetic door gasket(s) standard for positive door seal
- Two(2) pre-installed shelves per section
- Side mount compressor with environmentally friendly R290 refrigerant
- Pre-installed casters



MCK-PICL1-HC



MCK-PICL2-HC



MCK-PICL3-HC

*Don't forget to leave the unit some room to breathe!  
 Please clean the condenser frequently  
 to give the unit more fresh air.*





## SPECIFICATIONS

Model	Door	Capacity (Cu. Ft.)	Shelves	Casters (Inch)	Rated Current (A)	Voltage (V/Hz/Ph)	HP	Refrigerant	Exterior Dimensions	Net Weight (lbs)	Gross Weight (lbs)
MCK-PICL1-HC	1	13.8	2	5	2.64	115/60/1	1/5	R290	49 7/8 x 31 1/2 x 42	238	295
MCK-PICL2-HC	2	16.9	4	5	3.42	115/60/1	1/5	R290	70 9/10 x 31 1/2 x 42	335	406
MCK-PICL3-HC	3	24.2	6	5	5.28	115/60/1	1/4+	R290	91 9/10 x 31 1/2 x 42	428	527

## PLAN VIEW

MCK-PICL1-HC

MCK-PICL2-HC

MCK-PICL3-HC

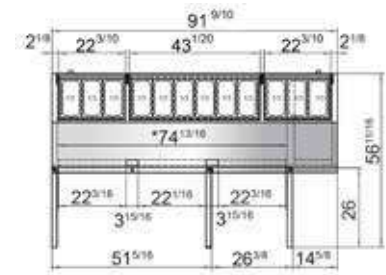
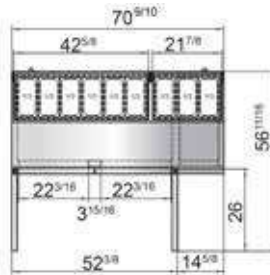
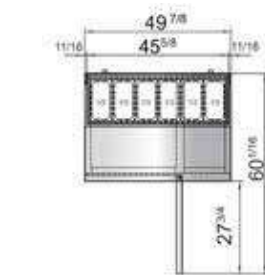
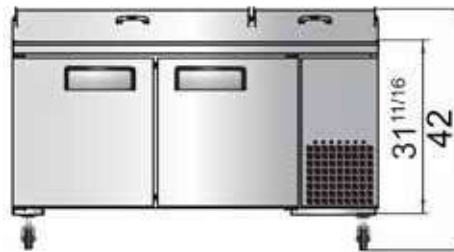
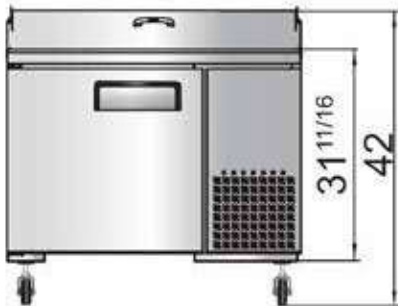

Side Dimensions

Casters



Epoxy shelves

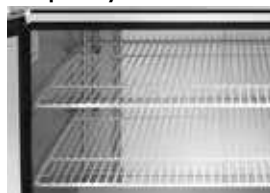

SS Pan



Control





Toll free +1 (833) 978 8833  
sales@mckequipment.ca  
Visit [mckonline.ca](http://mckonline.ca) for more details



# **UNDERCOUNTER & WORKTOPS REFRIGERATORS**

Worktop Refrigerator

Worktop Freezer

Undercounter Refrigerators

Undercounter Freezers



Toll free +1 (833) 978 8833  
 sales@mckequipment.ca  
 Visit [mckonline.ca](http://mckonline.ca) for more details

Quality Kitchen  
 Equipment & Supplies



# Worktop Refrigerators

MCK-UWT-27R-HC | MCK-UWT-48R-HC |  
 MCK-UWT-60R-HC | MCK-UWT-72R-HC

## FEATURES

- Stainless steel exterior & interior
- Rear mount compressor with environmentally friendly R290 refrigerant
- Dixell digital controller
- Maintains temperatures between 33°F - 41°F
- Recessed door handle(s)
- Self-closing door(s) with stay open feature
- Adjustable shelves with heavy duty PVC coat
- Magnetic door gasket(s) standard for positive door seal
- One(1) pre-installed shelf per section
- Pre-installed casters with breaks



MCK-UWT-27R-HC



MCK-UWT-48R-HC



MCK-UWT-72R-HC



MCK-UWT-60R-HC

*Don't forget to leave the unit some room to breathe!  
 Please clean the condenser frequently  
 to give the unit more fresh air.*





## SPECIFICATIONS

Model	Door	Capacity (Cu. Ft.)	Casters	Shelves (Inch)	Rated Current (A)	Voltage (V/Hz/Ph)	HP	Refrigerant	Exterior Dimensions	Net Weight (lbs)	Gross Weight (lbs)
MCK-UWT-27R-HC	1	6.3	1	2	1.9	115/60/1	1/6	R290	27 x 29 1/2 x 38 3/4	137	172
MCK-UWT-48R-HC	2	12	2	2	2.7	115/60/1	1/5	R290	47 1/5 x 29 1/2 x 38 3/4	192	231
MCK-UWT-60R-HC	2	15	2	2	2.9	115/60/1	1/5	R290	60 1/5 x 29 1/2 x 38 3/4	218	265
MCK-UWT-72R-HC	3	15.5	3	2	3.2	115/60/1	1/5	R290	72 x 29 1/2 x 38 3/4	254	315

## PLAN VIEW

MCK-UWT-27R-HC



MCK-UWT-48R-HC

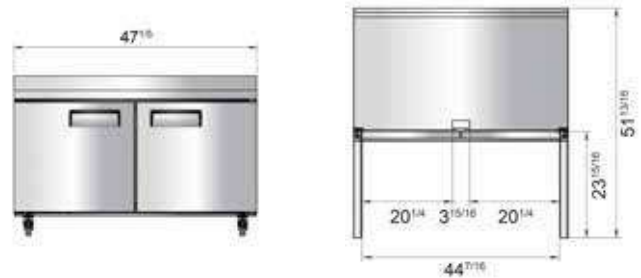

MCK-UWT-60R-HC

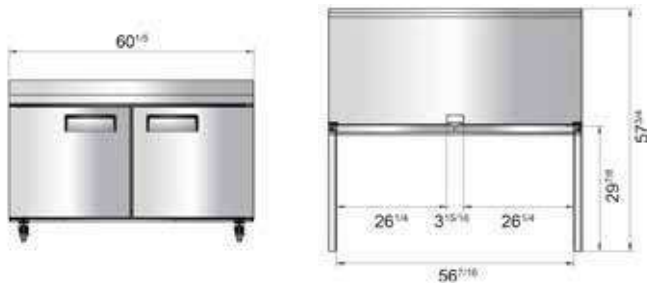

MCK-UWT-72R-HC



Side Dimensions



Casters



Rear



Shelve level



Control





Toll free +1 (833) 978 8833  
 sales@mckequipment.ca  
 Visit [mckonline.ca](http://mckonline.ca) for more details

Quality Kitchen  
 Equipment & Supplies



# Worktop Freezer

MCK-UWT-27F-HC | MCK-UWT-48F-HC |  
 MCK-UWT-60F-HC | MCK-UWT-72F-HC

## FEATURES

- Stainless steel exterior & interior
- Rear mount compressor with environmentally friendly R290 refrigerant
- Digital controller
- Maintains temperatures between -8°F - -0°F
- Recessed door handle(s)
- Self-closing door(s) with stay open feature
- Magnetic door gasket(s) standard for positive door seal
- One(1) pre-installed shelf per section
- Pre-installed casters



MCK-UWT-27F-HC



MCK-UWT-48F-HC



MCK-UWT-72F-HC



MCK-UWT-60F-HC

**Don't forget to leave the unit some room to breathe!**  
 Please clean the condenser frequently  
 to give the unit more fresh air.





### SPECIFICATIONS

Model	Door	Capacity (Cu. Ft.)	Shelves	Casters (Inch)	Rated Current (A)	Voltage (V/Hz/Ph)	HP	Refrigerant	Exterior Dimensions	Net Weight (lbs)	Gross Weight (lbs)
MCK-UWT-27F-HC	1	6.3	1	2	2.1	115/60/1	1/5	R290	27 1/2 x 30 x 34 1/4	146	137
MCK-UWT-48F-HC	2	12	2	2	4.5	115/60/1	1/4+	R290	48 1/4 x 30 x 34 1/4	172	222
MCK-UWT-60F-HC	2	15	2	2	6.36	115/60/1	1/2+	R290	60 1/4 x 30 x 34 1/4	203	245
MCK-UWT-72F-HC	3	15.5	3	2	6.36	115/60/1	5/8	R290	72 x 29 1/2 x 38 3/4	360	408

### PLAN VIEW

MCK-UWT-27F-HC



MCK-UWT-48F-HC

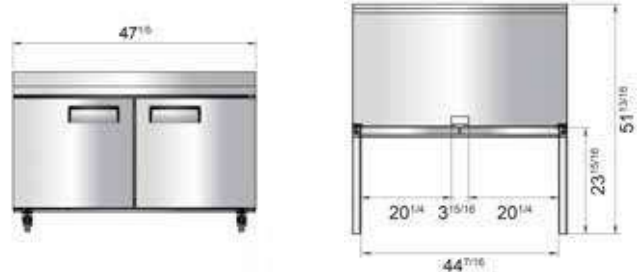

MCK-UWT-60F-HC



MCK-UWT-72F-HC



Side Dimensions



Casters



Rear



Shelve level



Control





Toll free +1 (833) 978 8833  
 sales@mckequipment.ca  
 Visit [mckonline.ca](http://mckonline.ca) for more details

Quality Kitchen  
 Equipment & Supplies



# Undercounter Refrigerators

MCK-UUC-27R-HC | MCK-UUC-48R-HC |  
 MCK-UUC-60R-HC

## FEATURES

- Stainless steel exterior & interior
- Rear mount compressor with environmentally friendly R290 refrigerant
- Dixell digital controller
- Maintains temperatures between 33°F - 41°F
- Recessed door handle(s)
- Self-closing door(s) with stay open feature
- Magnetic door gasket(s) standard for positive door seal
- One(1) pre-installed shelf per section
- Pre-installed casters



MCK-UUC-27R-HC



MCK-UUC-48R-HC



MCK-UUC-72R-HC



MCK-UUC-60R-HC

*Don't forget to leave the unit some room to breathe!  
 Please clean the condenser frequently  
 to give the unit more fresh air.*





## SPECIFICATIONS

Model	Door	Capacity (Cu. Ft.)	Shelves	Casters (Inch)	Rated Current (A)	Voltage (V/Hz/Ph)	HP	Refrigerant	Exterior Dimensions	Net Weight (lbs)	Gross Weight (lbs)
MCK-UUC-27R-HC	1	6.3	1	2	1.9	115/60/1	1/6	R290	27 1/2 x 30 x 34 1/5	137	172
MCK-UUC-48R-HC	2	12	2	2	2.7	115/60/1	1/5	R290	48 1/4 x 30 x 34 1/5	192	231
MCK-UUC-60R-HC	2	15	2	2	2.9	115/60/1	1/5	R290	60 1/5 x 30 x 34 1/5	218	265
MCK-UUC-72R-HC	3	15.5	3	2	3.2	115/60/1	1/5	R290	72 x 30 x 34 1/5	254	315

## PLAN VIEW

MCK-UUC-27R-HC

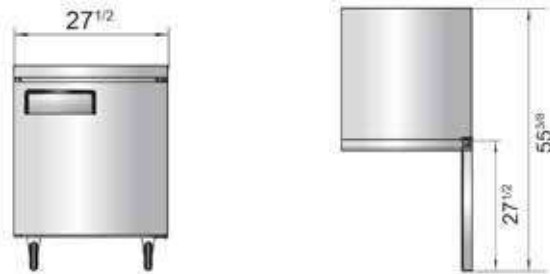

MCK-UUC-48R-HC



MCK-UUC-60R-HC



MCK-UUC-72R-HC

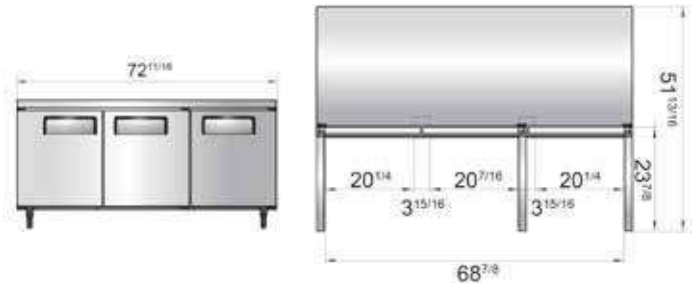

### Side Dimensions



Casters



Rear



Shelve level



Control





Toll free +1 (833) 978 8833  
 sales@mckequipment.ca  
 Visit [mckonline.ca](http://mckonline.ca) for more details

Quality Kitchen  
 Equipment & Supplies



# Undercounter Freezer

MCK-UUC-27F-HC | MCK-UUC-48F-HC |  
 MCK-UUC-60F-HC

## FEATURES

- Stainless steel exterior & interior
- Rear mount compressor with environmentally friendly R290 refrigerant
- Digital controller
- Maintains temperatures between -8°F - -0°F
- Recessed door handle(s)
- Self-closing door(s) with stay open feature
- Magnetic door gasket(s) standard for positive door seal
- One(1) pre-installed shelf per section
- Pre-installed casters



MCK-UUC-27F-HC



MCK-UUC-48F-HC



MCK-UUC-60F-HC

*Don't forget to leave the unit some room to breathe!  
 Please clean the condenser frequently  
 to give the unit more fresh air.*





### SPECIFICATIONS

Model	Door	Capacity (Cu. Ft.)	Shelves	Casters (Inch)	Rated Current (A)	Voltage (V/Hz/Ph)	HP	Refrigerant	Exterior Dimensions	Net Weight (lbs)	Gross Weight (lbs)
MCK-UUC-27F-HC	1	6.3	1	2	2.1	115/60/1	1/5	R290	27 1/2 x 30 x 34 1/5	146	137
MCK-UUC-48F-HC	2	12	2	2	4.5	115/60/1	1/4+	R290	48 1/4 x 30 x 34 1/5	172	222
MCK-UUC-60F-HC	2	15	2	2	6.36	115/60/1	1/2+	R290	60 1/5 x 30 x 34 1/5	203	245

### PLAN VIEW

MCK-UUC-27F-HC



MCK-UUC-48F-HC

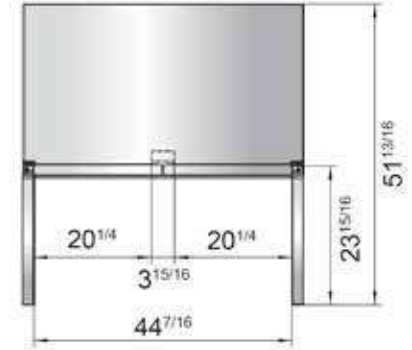

MCK-UUC-60F-HC

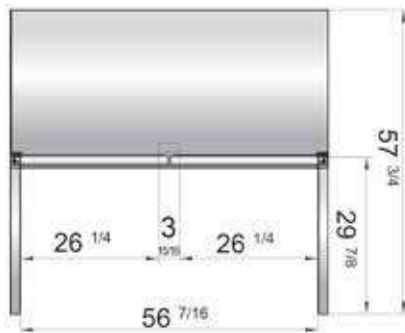

Side Dimensions



Casters



Rear



Shelve level



Control





Toll free +1 (833) 978 8833  
sales@mckequipment.ca  
Visit [mckonline.ca](http://mckonline.ca) for more details



# **REFRIGERATED CHEF BASE**

48",52",60", 72"and76"  
Refrigerated Chef Base



Toll free +1 (833) 978 8833  
 sales@mckequipment.ca  
 Visit [mckonline.ca](http://mckonline.ca) for more details

Quality Kitchen  
 Equipment & Supplies



# Refrigerated Chef Bases

MCK-CB36-HC | MCK-CB52-HC | MCK-CB72-HC

## FEATURES

- Stainless steel exterior and interior
- Stainless steel pans included
- Electronic temperature controller
- Maintains temperatures between 34F - 40F
- Heavy duty compressor with R290 refrigerant
- Stainless steel drawer slides and rollers
- Magnetic drawer gaskets
- Recessed door handles
- Pre-installed casters
- One-piece heavy duty reinforced stainless steel top to support counter top equipment
- Corner guards included
- Pull out handles included

## OTHER ACCESSORIES

- Extra shelves – includes 4 shelf clips per shelf



MCK-CB36-HC



MCK-CB52-HC



MCK-CB72-HC

*Don't forget to leave the unit some room to breathe!  
 Please clean the condenser frequently  
 to give the unit more fresh air.*





### SPECIFICATIONS

Model	Drawers	Capacity (Cu. Ft.)	Pans per Drawer	Casters (Inch)	Rated Current (A)	Voltage (V/Hz/Ph)	HP	Refrigerant	Exterior Dimensions	Net Weight (lbs)	Gross Weight (lbs)
MCK-CB36-HC	2	5.9	2* 1/1 + 6* 1/6	5	2.52	115/60/1	1/6	R290	36 3/8 × 32 1/8 × 25 3/8	170	218
MCK-CB52-HC	2	9.9	6* 1/1	5	3.48	115/60/1	1/6	R290	52 7/8 × 32 1/8 × 25 3/8	234	282
MCK-CB72-HC	4	15	8* 1/1	5	4.68	115/60/1	1/5	R290	72 3/8 × 32 1/8 × 25 3/8	300	364

### PLAN VIEW

MCK-CB36-HC

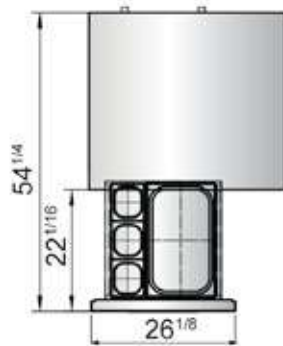

MCK-CB52-HC

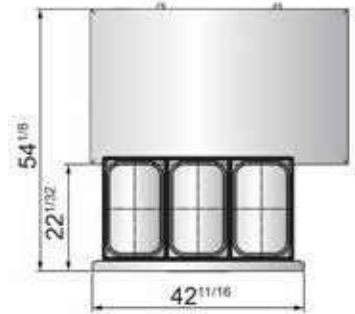
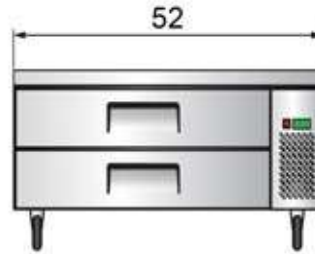

MCK-CB72-HC

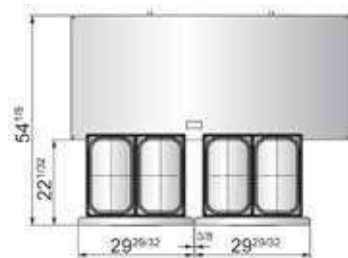

Side Dimensions

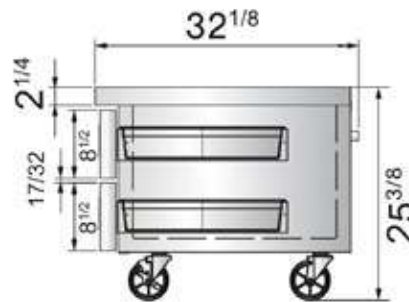

Casters



Rear



SS Pans



Temp. Control





Toll free +1 (833) 978 8833  
 sales@mckequipment.ca  
 Visit [mckonline.ca](http://mckonline.ca) for more details

Quality Kitchen  
 Equipment & Supplies



# Refrigerated Chef Bases

MCK-CB48-HC | MCK-CB60-HC | MCK-CB84-HC

## FEATURES

- Stainless steel exterior and interior
- Stainless steel pans included
- Electronic temperature controller
- Maintains temperatures between 34F - 40F
- Heavy duty compressor with R290 refrigerant
- Stainless steel drawer slides and rollers
- Magnetic drawer gaskets
- Recessed door handles
- Pre-installed casters
- One-piece heavy duty reinforced stainless steel top to support counter top equipment
- Corner guards included
- Pull out handles included

## OTHER ACCESSORIES

- Extra shelves – includes 4 shelf clips per shelf



MCK-CB48-HC



MCK-CB60-HC



MCK-CB84-HC

*Don't forget to leave the unit some room to breathe!  
 Please clean the condenser frequently  
 to give the unit more fresh air.*





## SPECIFICATIONS

Model	Drawers	Capacity (Cu. Ft.)	Pans per Drawer	Casters (Inch)	Rated Current (A)	Voltage (V/Hz/Ph)	HP	Refrigerant	Exterior Dimensions	Net Weight (lbs)	Gross Weight (lbs)
MCK-CB48-HC	2	9.6	4*1/1 + 6*1/6	5	2.52	115/60/1	1/6	R290	48 3/8 × 32 1/8 × 25 4/5	170	218
MCK-CB60-HC	2	12.7	6*1/1 + 6*1/6	5	3.48	115/60/1	1/6	R290	60 × 32 1/8 × 25 4/5	234	282
MCK-CB84-HC	4	19	10*1/1	5	4.68	115/60/1	1/5	R290	84 × 32 1/8 × 25 4/5	300	364

## PLAN VIEW

MCK-CB48-HC

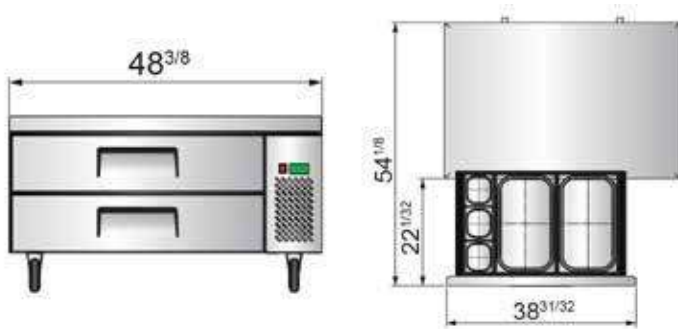

MCK-CB60-HC

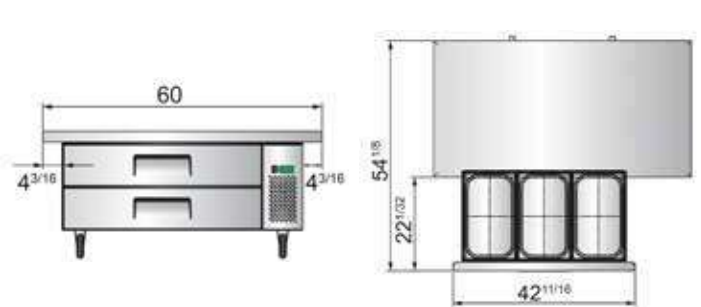

MCK-CB84-HC



Side Dimensions

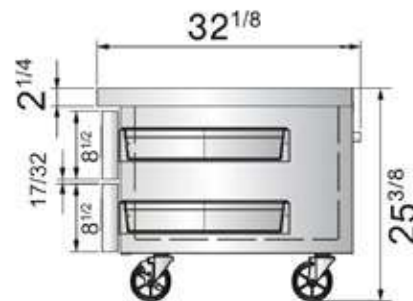

Casters



Rear



SS Pans



Temp. Control





Toll free +1 (833) 978 8833  
sales@mckequipment.ca  
Visit [mckonline.ca](http://mckonline.ca) for more details



# **CHEST FREEZER**

Solid Top Chest Freezer  
Angle Curved Glass Top Chest Freezer



Toll free +1 (833) 978 8833  
 sales@mckequipment.ca  
 Visit [mckonline.ca](http://mckonline.ca) for more details

Quality Kitchen  
 Equipment & Supplies



# Solid Top Chest Freezers

MCK-GD-BD-450 | MCK-GD-BD-550

## FEATURES

- Solid top freezers, designed to store ice cream and all types of frozen merchandise or seasonal specialties
- 3" insulation foam wall secure cold
- Environmentally friendly refrigeration system
- Manual temperature control
- Temperature -10 degrees F to -1 degree F
- Exterior white pre-coated steel cabinet is durable and permanent
- Interior white pre-coated aluminum is NSF sanitation approved
- Durable and easy to clean
- Standard door locks
- Manual defrosting with convenient defrost drain hole
- 1" diameter stem casters
- Standard Epoxy coated white basket



MCK-GD-BD-450



MCK-GD-BD-550

*Don't forget to leave the unit some room to breathe!  
 Please clean the condenser frequently  
 to give the unit more fresh air.*





### SPECIFICATIONS

Model	Door	Capacity (L/cu ft.)	Baskets	Watts (W)	Rated Current (A)	Voltage (V/Hz/Ph)	HP	Refrigerant	Exterior Dimensions	Net Weight (lbs)	Gross Weight (lbs)
MCK-GD-BD-450	1	368 / 22	1	86	1.5	110/60/1	1/8	R600a	48 x 27 x 33	134	152
MCK-GD-BD-550	1	459 / 34	1	91	2.6	110/60/1	1/5	R600a	60 x 27 x 33	163	185

### PLAN VIEW

MCK-GD-BD-450

MCK-GD-BD-550

Side Dimension

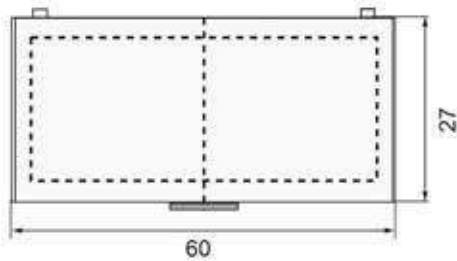
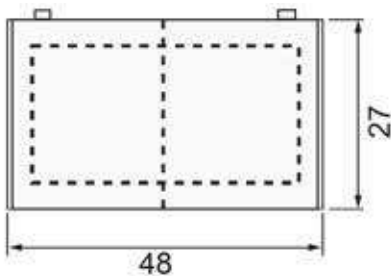
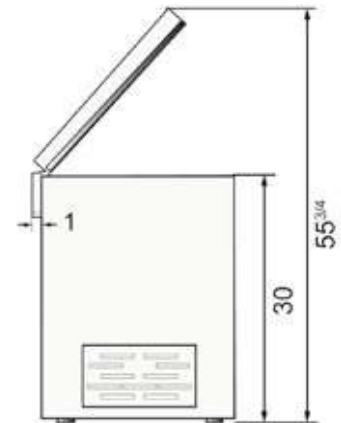
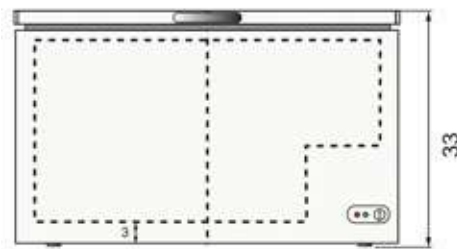
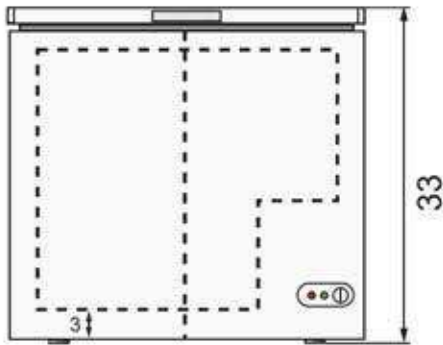

Casters



Drain Plug



Temp. Control



Epoxy Basket





Toll free +1 (833) 978 8833  
 sales@mckequipment.ca  
 Visit [mckonline.ca](http://mckonline.ca) for more details

Quality Kitchen  
 Equipment & Supplies



# Angle Curved Glass Top Chest Freezers

MCK-GD-SD-420Q | MCK-GD-SD-620Q

## FEATURES

- Solid top freezers, designed to store ice cream and all types of frozen merchandise or seasonal specialties
- 3" insulation foam wall secure cold
- Environmentally friendly refrigeration system
- Temperature -10 degrees F to -1 degree F
- Exterior white pre-coated steel cabinet is durable and permanent
- Interior white pre-coated aluminum is NSF sanitation approved
- Durable and easy to clean
- Standard door locks
- Convenient defrost drain
- 1" diameter stem casters
- Standard Epoxy coated white basket



MCK-GD-SD-420Q



MCK-GD-SD-620Q

*Don't forget to leave the unit some room to breathe!  
 Please clean the condenser frequently  
 to give the unit more fresh air.*





## SPECIFICATIONS

Model	Door	Baskets	Capacity (Cu. Ft.)	Casters (Inch)	Rated Current (A)	Voltage (V/Hz/Ph)	HP	Refrigerant	Exterior Dimensions	Net Weight (lbs)	Gross Weight (lbs)
MCK-GD-SD-420Q	2	3	9.6	2	1.6	115/60/1	1/8	R290	40 3/4 x 26 3/4 x 33 3/8	126	132
MCK-GD-SD-620Q	2	4	12.5	2	1.6	115/60/1	1/5	R290	50 1/8 x 26 3/4 x 33 3/8	145	150

## PLAN VIEW

MCK-GD-SD-420Q

MCK-GD-SD-620Q

Side Dimension

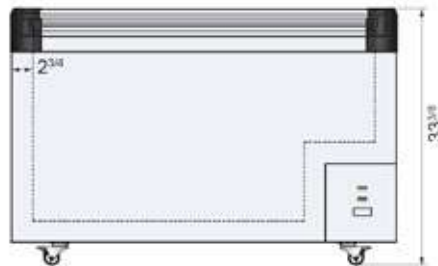
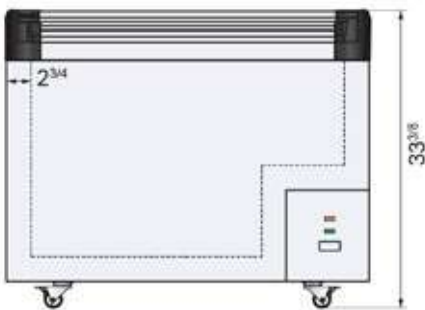

Casters



Drain Plug



Temp. Control



Epoxy Basket





Toll free +1 (833) 978 8833  
sales@mckequipment.ca  
Visit [mckonline.ca](http://mckonline.ca) for more details



# **UNDERCOUNTER ICE MAKERS**

Bullet Ice Maker  
280 lb. Ice Machine



Toll free +1 (833) 978 8833  
 sales@mckequipment.ca  
 Visit [mckonline.ca](http://mckonline.ca) for more details



# Bullet Ice Maker

MCK-GD-ZB-50A | MCK-GD-ZB-50B

## FEATURES

- Compact design, fits under counter.
- Full automatic running and easy to use
- Air cooling system, ventilate from front to rear
- Automatic detection and protection of overload, water shortage and ice full
- High efficiency CFC free compressor, economical and low energy consumption
- Ice production test conditions: ambient temperature of 21°C, water temperature 10°C



MCK-GD-ZB-50A



MCK-GD-ZB-50B

*Don't forget to leave the unit some room to breathe!  
 Please clean the condenser frequently  
 to give the unit more fresh air.*





Toll free +1 (833) 978 8833  
 sales@mckequipment.ca  
 Visit [mckonline.ca](http://mckonline.ca) for more details



### SPECIFICATIONS

Model	Ice Type	Ice Bin Capacity (lb.)	Capacity (lbs/hr)	Legs (inch)	Rated Current (A)	Voltage (V/Hz/Ph)	Power (w)	Refrigerant	Exterior Dimensions (inch)	Net Weight (lbs)	Gross Weight (lbs)
MCK-GD-ZB-50A	Bullet Ice	15.4	100	6	5.15	115/60/1	425	R134a	15.69 x 21.33 x 26.85	72	81
MCK-GD-ZB-50B		19.84	132						15.69 x 24.09 x 35.15	112	123

### PLAN VIEW

MCK-GD-ZB-50A

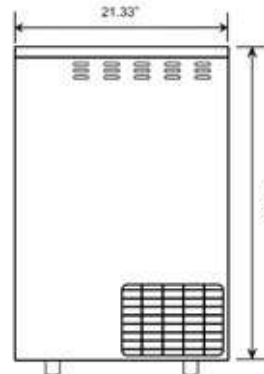
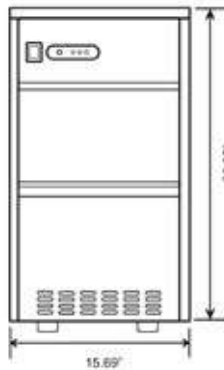

MCK-GD-ZB-50B

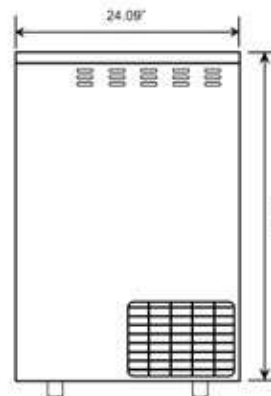
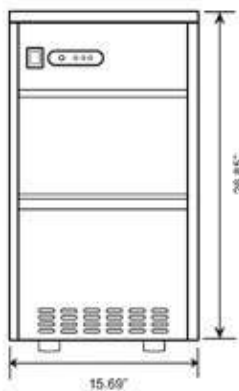

Bullet Ice



Short Legs



Inlet Hose



Drain Hose



Scoop





Toll free +1 (833) 978 8833  
 sales@mckequipment.ca  
 Visit [mckonline.ca](http://mckonline.ca) for more details

Quality Kitchen  
 Equipment & Supplies



# 280 lb. Ice Machine

MCK-IM-280AA-H-HC

## FEATURES

- Up to 280 lb. production ice machine (per 24 hrs)
- Built-in storage capacity of 88 lbs.
- Durable stainless steel exterior
- Slanted black plastic bin door
- Ice scoop included
- Height includes leg levelers
- Air cooled condenser
- For freestanding or built-in applications
- Requires use of a drain
- ETL Listed and ETL Sanitation Listed
- Removable air filter
- Power switch accessible without panel removal



## OTHER ACCESSORIES

- Inlet hose
- Drain hose
- Ice scooper

MCK-IM-280AA-H-HC

*Don't forget to leave the unit some room to breathe!  
 Please clean the condenser frequently  
 to give the unit more fresh air.*





Toll free +1 (833) 978 8833  
 sales@mckequipment.ca  
 Visit [mckonline.ca](http://mckonline.ca) for more details



### SPECIFICATIONS

Model	Type	Capacity (lbs/hr)	Leg (inch)	Watts (W)	Rated Current (A)	Voltage (V/Hz/Ph)	kWh/100 lbs Ice	Refrigerant	Exterior Dimensions	Ice Dimensions	Gross Weight (lbs)
MCK-IM-280AA-H-HC	Cube Ice	80	6	726	6.9	110/60/1	6.13	R290	26 x 27 3/5 x 38 1/2	3/8" x 7/8" x 7/8"	147

### PLAN VIEW

MCK-IM-280AA-H-HC

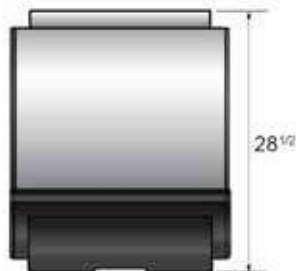

Side Dimensions



Half Cube



Inlet Hose



Drain Hose



Scoop



Connection





Toll free +1 (833) 978 8833  
sales@mckequipment.ca  
Visit [mckonline.ca](http://mckonline.ca) for more details



## **MODULAR ICE MAKERS**

350 lb. Ice Machine

530 lb. Ice Machine



Toll free +1 (833) 978 8833  
 sales@mckequipment.ca  
 Visit [mckonline.ca](http://mckonline.ca) for more details

Quality Kitchen  
 Equipment & Supplies



# 350 lb. Ice Machine

MCK-IM-350AA-H-HC

## FEATURES

- Up to 350 lb. production ice machine (per 24 hrs)
- Durable stainless steel exterior
- Air cooled condenser
- Requires use of a drain
- ETL Listed and ETL Sanitation Listed
- Removable air filter
- Power switch accessible without panel removal
- Optional Ice Bins available MCK-123, MCK-321

## OTHER ACCESSORIES

- Inlet hose
- Drain hose
- Ice scooper



MCK-IM-350AA-H-HC

*Don't forget to leave the unit some room to breathe!  
 Please clean the condenser frequently  
 to give the unit more fresh air.*





### SPECIFICATIONS

Model	Type	Capacity (lbs/hr)	Leg (inch)	Watts (W)	Rated Current (A)	Voltage (V/Hz/Ph)	kWh/100 lbs Ice	Refrigerant	Exterior Dimensions	Ice Dimensions	Gross Weight (lbs)
MCK-IM-350AA-H-HC	Cube Ice	350/24	6	790	6.5	220/60/1	5.18	R290	22 x 32 1/2 x 67 1/2	3/8" x 7/8" x 7/8"	350

### PLAN VIEW

MCK-IM-350AA-H-HC

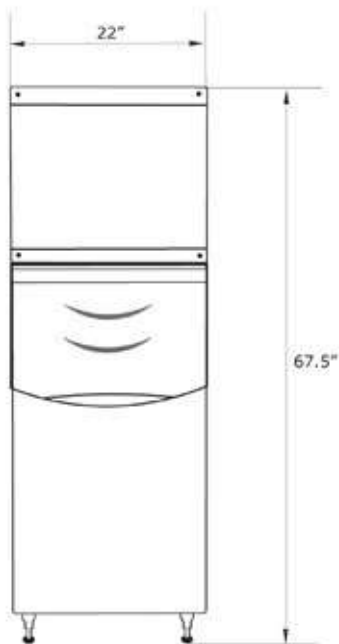

Side Dimensions

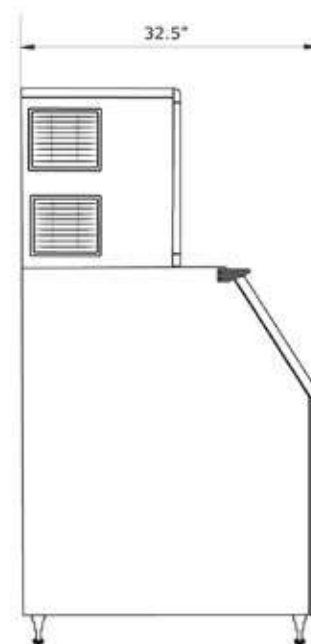

Half Cube



Inlet Hose



Drain Hose



Compressor





Toll free +1 (833) 978 8833  
 sales@mckequipment.ca  
 Visit [mckonline.ca](http://mckonline.ca) for more details

Quality Kitchen  
 Equipment & Supplies



# 530 lb. Ice Machine

MCK-IM-530AA-H-HC

## FEATURES

- Up to 350 lb production ice machine (per 24 hrs)
- Durable stainless steel exterior
- Air cooled condenser
- Requires use of a drain
- NSF and ETL listed
- Removable air filter
- Power switch accessible without panel removal
- Ice machine includes a 3M water filter
- Ice dimension: 3/8" x 7/8" x 7/8"
- NEMA L14-20P plug standard

## OTHER ACCESSORIES

- Inlet hose
- Drain hose
- Ice scooper



MCK-IM-530AA-H-HC

*Don't forget to leave the unit some room to breathe!  
 Please clean the condenser frequently  
 to give the unit more fresh air.*





### SPECIFICATIONS

Model	Type	Capacity (lbs/hr)	Leg (inch)	Watts (W)	Rated Current (A)	Voltage (V/Hz/Ph)	kWh/100 lbs Ice	Refrigerant	Exterior Dimensions	Ice Dimensions	Gross Weight (lbs)
MCK-IM-530AA-H-HC	Cube Ice	810/24	6	704	7.5	220/60/1	5.18	R-404a	31 x 24 x 22 3/8	3/8" x 7/8" x 7/8"	231

### PLAN VIEW

MCK-IM-530AA-H-HC

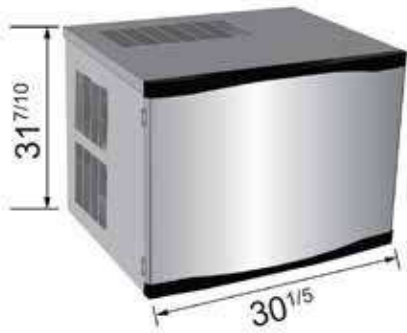

Side Dimensions

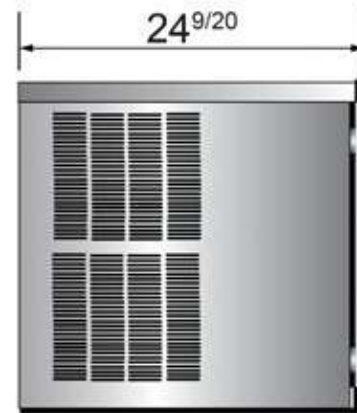

Half Cube



Inlet Hose



Drain Hose



Compressor





Toll free +1 (833) 978 8833  
sales@mckequipment.ca  
Visit [mckonline.ca](http://mckonline.ca) for more details



# **ICE STORAGE BINS**

400 lb & 700 lb. Ice Storage Bins



Toll free +1 (833) 978 8833  
 sales@mckequipment.ca  
 Visit [mckonline.ca](http://mckonline.ca) for more details

Quality Kitchen  
 Equipment & Supplies



# 400 lbs and 700 lbs Ice Storage Bins

MCK-IM-350AA | MCK-IM-530AA BIN

## FEATURES

- Bin holds up to 395 or 700 lb. of ice
- Durable stainless steel exterior
- Slanted black plastic bin door
- Ice scoop included
- Ice bins come standard with bin adapter
- Designed to work with MCK ice machines model MCK-1 and MCK-2

## OTHER ACCESSORIES

- Inlet hose
- Drain hose
- Ice scooper



MCK-IM-350AA Bin



MCK-IM-530AA Bin

*Don't forget to leave the unit some room to breathe!  
 Please clean the condenser frequently  
 to give the unit more fresh air.*





### SPECIFICATIONS

Model	Type	Capacity (lbs)	Leg (inch)	Foaming Material	Exterior Dimensions	Gross Weight (lbs)
MCK-IM-350AA Bin	Ice Bin	380	6	C5H10	23 X 32 X45	141
MCK-IM-530AA Bin	Ice Bin	500	6	C5H10	48 1/4 X 32 1/2 X 41	154

**Compatible for Ice machines**

- MCK-IM-350AA-H-HC
- MCK-IM-530AA-H-HC

### PLAN VIEW

MCK-IM-350AA Bin



MCK-IM-530AA Bin

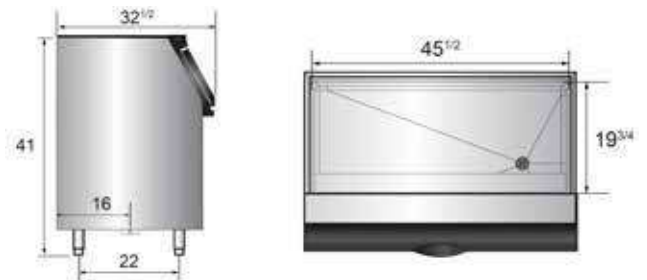
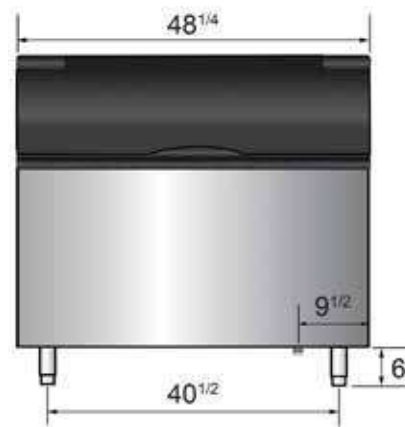

Half Cube



Inlet Hose



Drain Hose



Bin





Toll free +1 (833) 978 8833  
sales@mckequipment.ca  
Visit [mckonline.ca](http://mckonline.ca) for more details



# **WINE COOLER**

## Dual Zone Wine Coolers



Toll free +1 (833) 978 8833  
 sales@mckequipment.ca  
 Visit [mckonline.ca](http://mckonline.ca) for more details

Quality Kitchen  
 Equipment & Supplies



# Dual Zone Wine Cooler (54-168 Bottles)

MCK-GD-W54D | MCK-GD-W168D

## FEATURES

- Black finish with Seamless SS door frame with 2 layers of anti-UV brown glass
- Capacity to store 46 to 166 bottles
- 5-15 beechwood shelves
- Touchpad controller with LED displayer
- Fan cooling system for even temperature distribution
- Upper and lower temperature zones
- Temperature range:  
 Upper zone 5-12°C (41-54°F)  
 Lower zone 12-22°C (54-72°F)
- Blue LED top light
- Lock for added security
- Embraco compressor and R600a refrigerant for efficient operation
- Interior white LED light
- Interior temperature control
- Adjustable feet



MCK-GD-W54D



MCK-GD-W168D





Toll free +1 (833) 978 8833  
 sales@mckequipment.ca  
 Visit [mckonline.ca](http://mckonline.ca) for more details

Quality Kitchen  
 Equipment & Supplies



## SPECIFICATIONS

Model	Installation	Net Capacity C.F.	Capacity (Bottles)	Shelves	Temperature Control Range (°F)	Current (A)	Refrigerant	Gross Weight (lbs)	Exterior Dimensions (inch)	Net Weight (lbs)	Gross Weight (lbs)
MCK-GD-W54D	Built-in/ Free-standing installation	9.15	54	5	Upper 41-54 Lower 54-72	1.2	R600A	168	23.4 x 22.75 x 34.2	43	50
MCK-GD-W168D	Built-in/ Free-standing installation	27.46	168	15	Upper 41-54 Lower 54-72	1.6	R600A	212	23.4 x 26.75 x 70.4	92	98

## PLAN VIEW

MCK-GD-W54D | MCK-GD-W168D

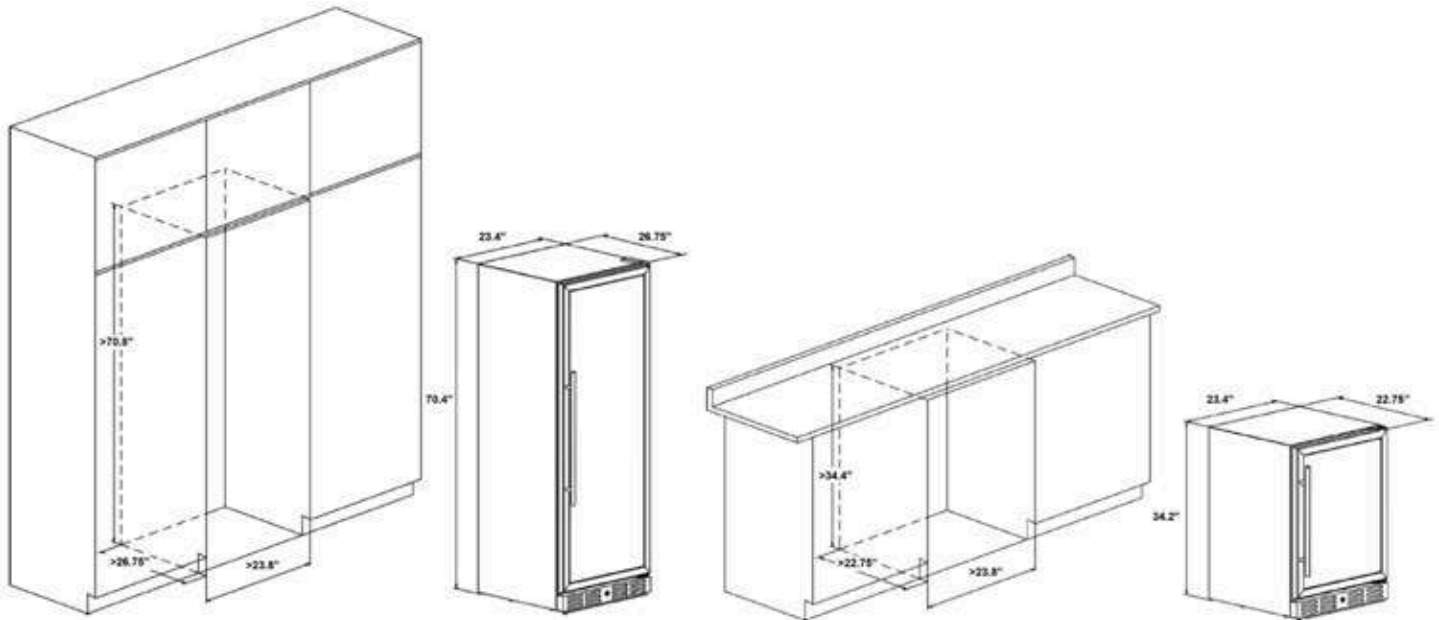

Steady Environment



Removable Racks



Stainless Steel



Lock Control





Toll free +1 (833) 978 8833  
sales@mckequipment.ca  
Visit [mckonline.ca](http://mckonline.ca) for more details



# **CAKE DISPLAY COOLER**

Countertop Cake Display



Toll free +1 (833) 978 8833  
 sales@mckequipment.ca  
 Visit [mckonline.ca](http://mckonline.ca) for more details

Quality Kitchen  
 Equipment & Supplies



# Countertop Curved Glass Cake Display

MCK-FT-100R

## FEATURES

- Brilliant Internal LED lighting at 2 sides.
- Adjustable glass shelves.
- One shelf is rotatable manually.
- Digital temperature control and display.
- Double tempered glass.
- 5 Castors (wheels) with front 2 brakes (Note: This is specified as "Only ARC-400R," suggesting it may be a model-specific feature).
- Ventilated cooling system.
- Automatic Defrost.
- Automatic closing door.
- Stainless steel body base.



MCK-FT-100R





Toll free +1 (833) 978 8833  
 sales@mckequipment.ca  
 Visit [mckonline.ca](http://mckonline.ca) for more details



## SPECIFICATIONS

Model	Temperature Range	Input Power	Refrigerant	Class Mate	Exterior Dimensions (inch)	Packaging Dimensions (inch)	Net Weight (lbs)	Gross Weight
MCK-FT-100R	2-8° (35.6-46.4 °F)	230W/ 210W	R134a/R600a	4/6	18.9 × 18.9 × 40.6	22.2 × 22.2 × 43.3	110.2	121.3
MCK-FT-400R	2-8° (35.6-46.4 °F)	480W/ 460W	R134a/R290	4	26.8 × 26.8 × 68.9	29.5 × 29.5 × 76	208	308.6

## PLAN VIEW

MCK-FT-400R

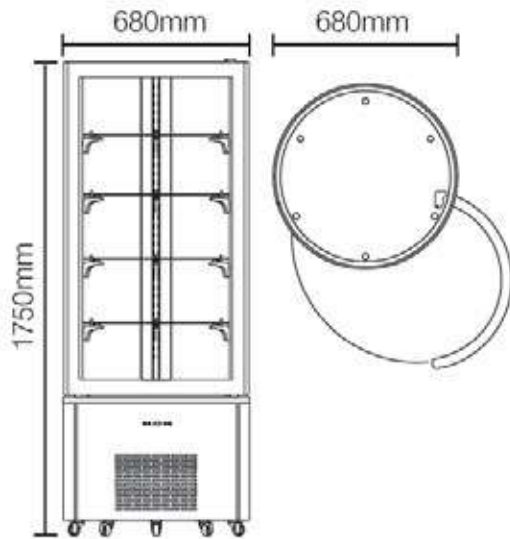

MCK-FT-100R

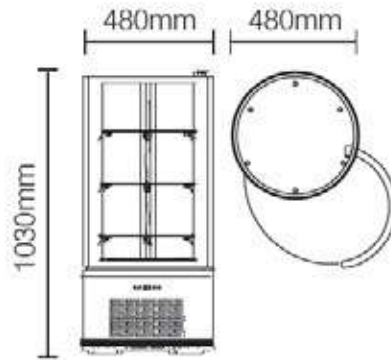

Interior LED lighting



3.53 cu. ft. capacity



S/S construction



Digital temp controller





Toll free +1 (833) 978 8833  
 sales@mckequipment.ca  
 Visit [mckonline.ca](http://mckonline.ca) for more details

Quality Kitchen  
 Equipment & Supplies



# Countertop Curved Glass Cake Display

MCK-RTC-72L | MCK-RTC-73L

## FEATURES

- Brilliant Internal LED illumination on 2 sides
- Digital temperature controller and display
- Rotational chrome plated shelves
- Round double glass
- Ventilated cooling system
- Automatic defrost



MCK-RTC-72L | MCK-RTC-73L





## SPECIFICATIONS

Model	Temperature Range	Input Power	Refrigerant	Class Mate	Exterior Dimensions (inch)	Packaging Dimensions (inch)	Net Weight (lbs)	Gross Weight (lbs)
MCK-RTC-72L	0-10° (32-50 °F)	190W/170W	R134a/R600a	4/N	17.7 x 17.7 x 38.7	19.7 x 19.7 x 41.3	84.9	90.4
MCK-RTC-73L	2-12° (35.6-53.6 °F)	209W/190W	R134a/R600a	4	19.8 x 19.8 x 41.7	20.7 x 20.7 x 43.3	45	47.5

## PLAN VIEW

MCK-RTC-72L

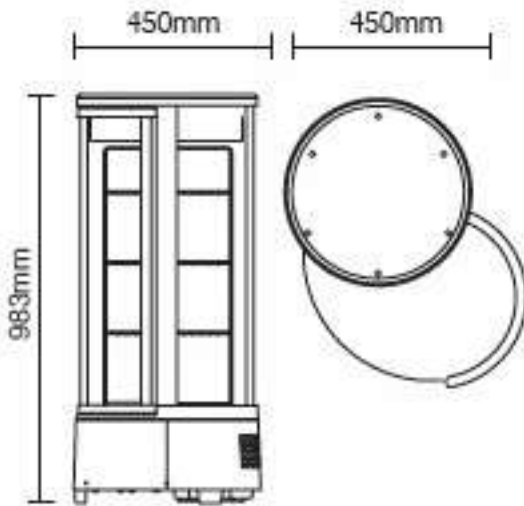

MCK-RTC-73L

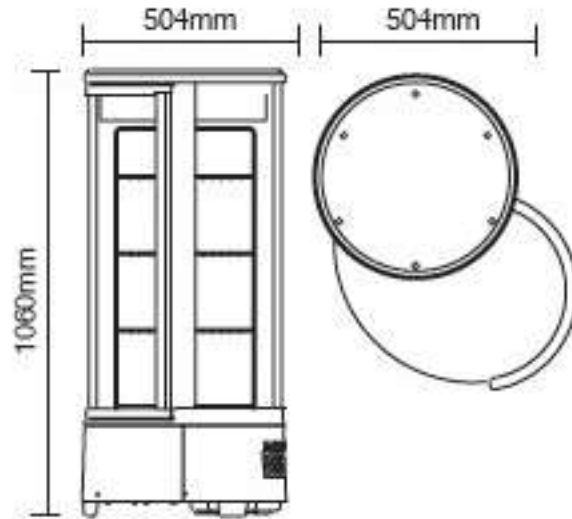

Double glass



Digital controller



Decrease condensation





Toll free +1 (833) 978 8833  
sales@mckequipment.ca  
Visit [mckonline.ca](http://mckonline.ca) for more details



# **COUNTERTOP COOKING EQUIPMENT**

Countertop Radiant Broilers  
Countertop Char Rock Broilers  
Manual Griddles  
Thermostatic Griddles  
Countertop Range (Hot Plates)  
Single & Double Stock Pot Stoves



Toll free +1 (833) 978 8833  
 sales@mckequipment.ca  
 Visit [mckonline.ca](http://mckonline.ca) for more details

Quality Kitchen  
 Equipment & Supplies



# Countertop Radiant Broilers

MCK-RB-24 | MCK-RB-36 | MCK-RB-48

## FEATURES

- Stainless steel exterior and interior
- 35,000 BTU stainless steel burners with standby pilot
- Independent manual controls every 12"
- Heavy-duty, reversible cast iron grates
- Top grates are adjustable multi-level
- Adjustable, stainless steel legs standard
- 3/4" NPT rear gas connection and regulator standard
- With LP conversion kit



MCK-RB-24



MCK-RB-36



MCK-RB-48





Toll free +1 (833) 978 8833  
 sales@mckequipment.ca  
 Visit [mckonline.ca](http://mckonline.ca) for more details

Quality Kitchen  
 Equipment & Supplies



## SPECIFICATIONS

Model	Door	Gas Type	Intake Tube Pressure (in. W.C.)	Per BTU B.T.U/h	Total BTU B.T.U/h	Regulator	Work Area (inch)	Exterior Dimensions (inch)	Net Weight (lbs)	Gross Weight (lbs)
MCK-RB-24	2 Burners, Independent Manual Control	NG	4	35,000	70,000	4" w.c	23 9/10 x 20 1/5	24 x 27 3/5 x 15 1/5	117	147
		LP	10	35,000	70,000	10" w.c				
MCK-RB-36	3 Burners, Independent Manual Control	NG	4	35,000	105,000	4" w.c	35 7/10 x 20 1/5	36 x 27 3/5 x 15 1/5	159	205
		LP	10	35,000	105,000	10" w.c				
MCK-RB-48	4 Burners, Independent Manual Control	NG	4	35,000	140,000	4" w.c	47 9/10 x 20 1/5	48 x 27 3/5 x 15 1/5	201	256

## PLAN VIEW

MCK-RB-24

MCK-RB-36

MCK-RB-48

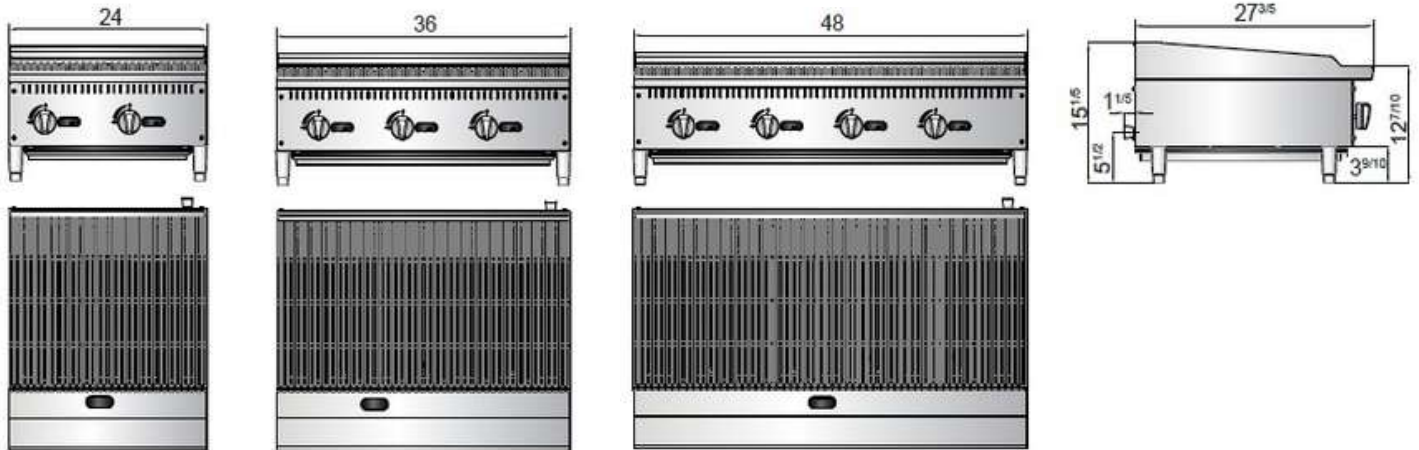

Stainless steel knobs



Inlet pipe



Radiant



Stainless steel legs



Cast iron grates





Toll free +1 (833) 978 8833  
 sales@mckequipment.ca  
 Visit mckonline.ca for more details

Quality Kitchen  
 Equipment & Supplies



# Countertop Char Rock Broilers

MCK-CB-24 | MCK-CB-36 | MCK-CB-48

## FEATURES

- Stainless steel exterior and interior
- 35,000 BTU stainless steel burners with standby pilot
- Independent manual controls every 12"
- Heavy-duty, reversible cast iron grates
- Top grates are adjustable multi-level
- Adjustable, stainless steel legs standard
- 3/4" NPT rear gas connection and regulator standard
- With LP conversion kit



MCK-CB-24



MCK-CB-36



MCK-CB-48





### SPECIFICATIONS

Model	Door	Gas Intake Tube Type	Pressure (in. W.C.)	Per BTU B.T.U/h	Total BTU B.T.U/h	Regulator	Work Area (inch)	Exterior Dimensions (inch)	Net Weight (lbs)	Gross Weight (lbs)
MCK-CB-24	2 Burners, Independent Manual Control	NG	4	35,000	70,000	4" w.c	23 9/10 x 20 1/5	24 x 27 3/5 x 15 1/5	137	168
MCK-CB-36	3 Burners, Independent Manual Control	NG	4	35,000	105,000	4" w.c	35 7/10 x 20 1/5	36 x 27 3/5 x 15 1/5	191	238
MCK-CB-48	4 Burners, Independent Manual Control	NG	4	35,000	140,000	4" w.c	47 9/10 x 20 1/5	48 x 27 3/5 x 15 1/5	248	314

### PLAN VIEW

MCK-CB-24

MCK-CB-36

MCK-CB-48

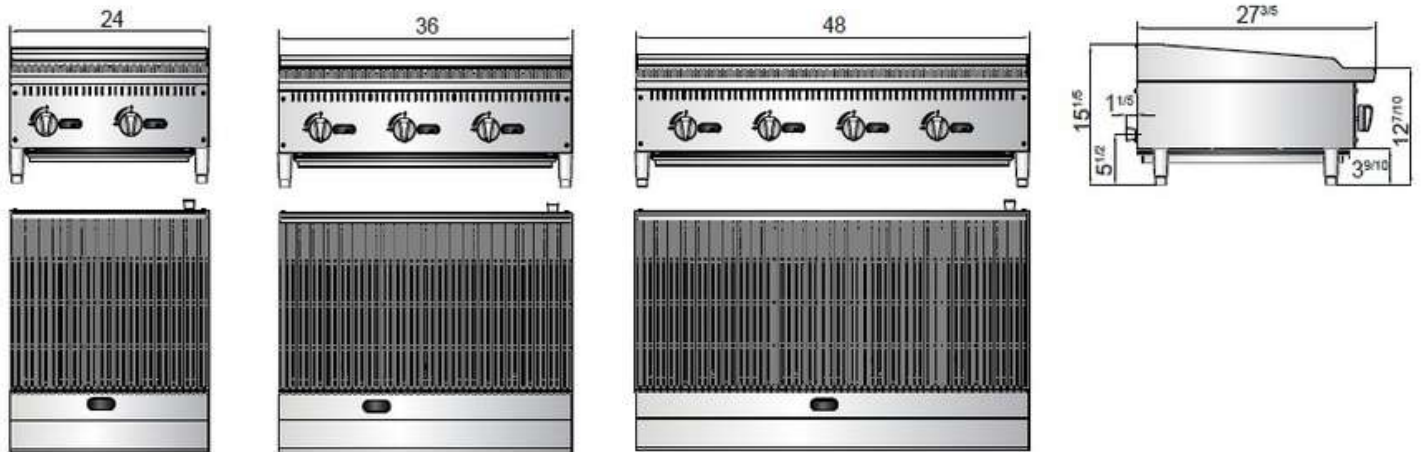

Stainless steel knobs



Cast iron grates



Stainless steel legs





Toll free +1 (833) 978 8833  
 sales@mckequipment.ca  
 Visit [mckonline.ca](http://mckonline.ca) for more details

Quality Kitchen  
 Equipment & Supplies



# Manual Griddles

MCK-GG-24 | MCK-GG-36 | MCK-GG-48

## FEATURES

- Stainless steel exterior & interior
- Stainless steel grease drawer
- Heavy duty 3/4" thick polished steel griddle plate
- 30,000 BTU burners per 12" section with standby pilots
- Independent manual controls for each 12" section
- Stainless steel legs standard
- 3/4" NPT rear gas connection and regulator standard
- With LP conversion kit



MCK-GG-24



MCK-GG-36



MCK-GG-48





Toll free +1 (833) 978 8833  
 sales@mckequipment.ca  
 Visit [mckonline.ca](http://mckonline.ca) for more details

Quality Kitchen  
 Equipment & Supplies



## SPECIFICATIONS

Model	Door	Gas Type	Intake Tube Pressur (in. W.C.)	Per BTU B.T.U/h	Total BTU B.T.U/h	Reguiator	WorkArea (inch)	Exterior Dimensions (inch)	Net Weight (lbs)	Gross Weight (lbs)
MCK-GG-24	2 Burners, Independent Manual Control	NG	4	30,000	60,000	4" w.c	23 9/10 x 19 9/10	24 x 28 3/5 x 15 1/5	161	195
		LP	10	30,000	60,000	10" w.c				
MCK-GG-36	3 Burners, Independent Manual Control	NG	4	30,000	90,000	4" w.c	35 7/10 x 19 9/10	36 x 28 3/5 x 15 1/5	229	281
		LP	10	30,000	90,000	10" w.c				
MCK-GG-48	4 Burners, Independent Manual Control	NG	4	30,000	120,000	4" w.c	47 9/10 x 19 9/10	48 x 28 3/5 x 15 1/5	294	414
		LP	10	30,000	120,000	10" w.c				

## PLAN VIEW

MCK-GG-24

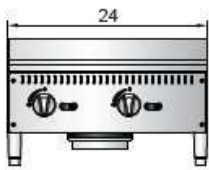

MCK-GG-36

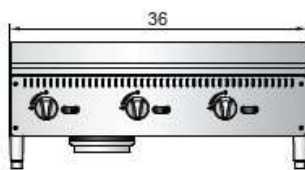

MCK-GG-48

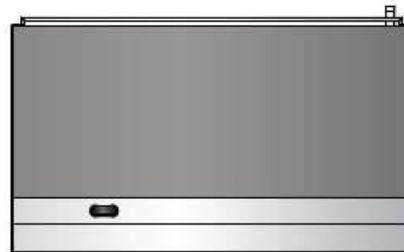
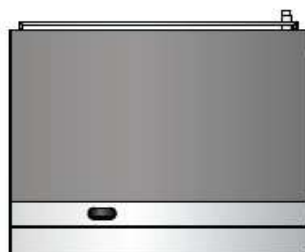
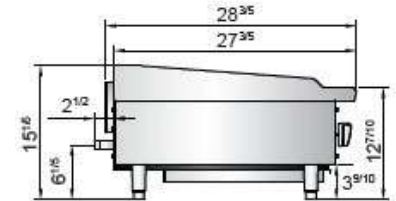
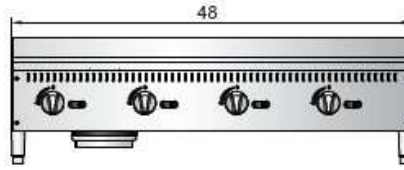

Stainless steel knobs



Dripping hole



Dripping pan



Stainless steel legs





# Manual Griddles

## FEATURES:

- Stainless steel exterior & interior
- Stainless steel grease drawer
- Heavy duty 3/4" thick polished steel griddle plate
- 30,000 BTU burners per 12" section with standby pilots
- Independent manual controls for each 12" section
- Stainless steel legs standard
- 3/4" NPT rear gas connection and regulator standard
- With LP conversion kit



**MCK-CG-24**



**MCK-CG-36**





Toll free +1 (833) 978 8833  
 sales@mckequipment.ca  
 Visit [mckonline.ca](http://mckonline.ca) for more details



**SPECIFICATIONS**

Model	Burners /Controls	Gas Type	Per BTU	Total BTU	Work Area (inch)	Exterior Dimensions (inch)	Net Weight (lbs)	Gross Weight (lbs)
MCK-CG-24	2 Burners, 2 Controls	NG / LPG	30,000	60,000	23.60" x 18.98"	23.78" x 26.03" x 15.92"	125.6	172
MCK-CG-36	3 Burners, 3 Controls	NG / LPG	30,000	90,000	35.41" x 18.98"	36.00" x 26.11" x 15.92"	165.3	212

**PLAN VIEW**

MCK-CG-24

MCK-CG-36

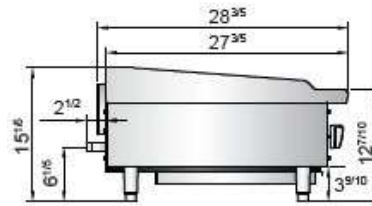
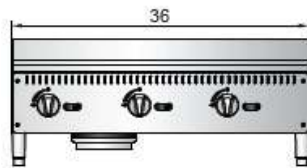
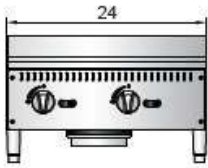

Stainless steel knobs



Dripping hole



Dripping pan



Stainless steel legs





Toll free +1 (833) 978 8833  
 sales@mckequipment.ca  
 Visit [mckonline.ca](http://mckonline.ca) for more details

Quality Kitchen  
 Equipment & Supplies



# Thermostatic Griddles

MCK-GG-24T | MCK-GG-36T | MCK-GG-48T

## FEATURES

- Stainless steel exterior & interior
- Stainless steel grease drawer
- Heavy duty 1" thick polished steel griddle plate
- 25,000 BTU burners per 12" section with standby pilots
- Independent manual controls for each 12" section
- Stainless steel legs standard
- 3/4" NPT rear gas connection and regulator standard
- With LP conversion kit



MCK-GG-24T



MCK-GG-36T



MCK-GG-48T





Toll free +1 (833) 978 8833  
 sales@mckequipment.ca  
 Visit [mckonline.ca](http://mckonline.ca) for more details

Quality Kitchen  
 Equipment & Supplies



## SPECIFICATIONS

Model	Door	Gas Type	Intake Tube Pressure (in. W.C.)	Per BTU B.T.U/h	Total BTU B.T.U/h	Reguiator	WorkArea (inch)	Exterior Dimensions (inch)	Net Weight (lbs)	Gross Weight (lbs)
MCK-GG-24T	2 Burners, Independent Manual Control	NG	4	25,000	50,000	4" w.c	23 9/10 x 19 9/10	24 x 28 3/5 x 15 1/5	161	195
		LP	10	25,000	50,000	10" w.c				
MCK-GG-36T	3 Burners, Independent Manual Control	NG	4	25,000	75,000	4" w.c	35 7/10 x 19 9/10	36 x 28 3/5 x 15 1/5	229	281
		LP	10	25,000	75,000	10" w.c				
MCK-GG-48T	4 Burners, Independent Manual Control	NG	4	25,000	100,000	4" w.c	47 9/10 x 19 9/10	48 x 28 3/5 x 15 1/5	295	415
		LP	10	25,000	100,000	10" w.c				

## PLAN VIEW

MCK-GG-24T

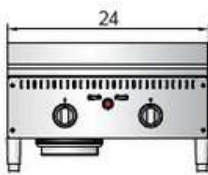

MCK-GG-36T

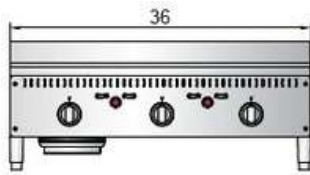

MCK-GG-48T

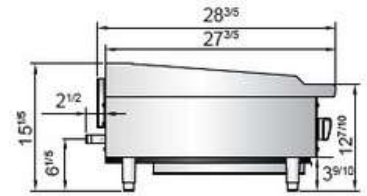
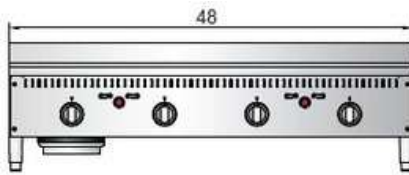

Stainless steel knobs



Dripping hole



Dripping pan



Stainless steel legs





Toll free +1 (833) 978 8833  
 sales@mckequipment.ca  
 Visit [mckonline.ca](http://mckonline.ca) for more details

Quality Kitchen  
 Equipment & Supplies



# Countertop Ranges (Hot Plates)

MCK-HP2 | MCK-HP4 | MCK-HP6

## FEATURES

- Stainless steel exterior and interior
- Stainless steel full width crumb tray
- 32,000 BTU burners
- Heavy duty burners with a standing pilot for open top burners
- Heavy duty cast iron top grates
- Independent manual controls for each burner
- Stainless steel legs standard
- 3/4 inch NPT rear gas connection and regulator standard
- With LP conversion kit



MCK-HP2



MCK-HP4



MCK-HP6





Toll free +1 (833) 978 8833  
 sales@mckequipment.ca  
 Visit [mckonline.ca](http://mckonline.ca) for more details

Quality Kitchen  
 Equipment & Supplies



## SPECIFICATIONS

Model	Door	Gas Type	Intake Tube Pressure (in. w.c.)	Per BTU B.T.U/h	Total BTU B.T.U/h	Regulator	Exterior Dimensions (inch)	Net Weight (lbs)	Gross Weight (lbs)
MCK-HP2	2 Burners, Independent Manual Control	NG	4	32,000	64,000	4" w.c.	12 x 27 3/5 x 13 1/10	54	74
		LP	10	32,000	64,000	10" w.c.			
MCK-HP4	4 Burners, Independent Manual Control	NG	4	32,000	128,000	4" w.c.	24 x 27 3/5 x 13 1/10	94	125
		LP	10	32,000	128,000	10" w.c.			
MCK-HP6	6 Burners, Independent Manual Control	NG	4	32,000	192,000	4" w.c.	36 x 27 3/5 x 13 1/10	134	180
		LP	10	32,000	192,000	10" w.c.			

## PLAN VIEW

MCK-HP2

MCK-HP4

MCK-HP6

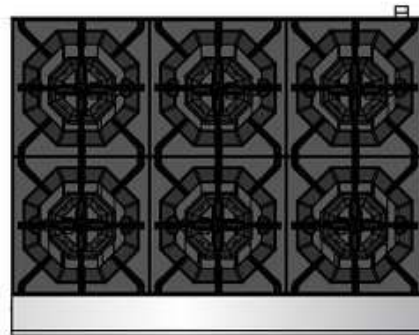
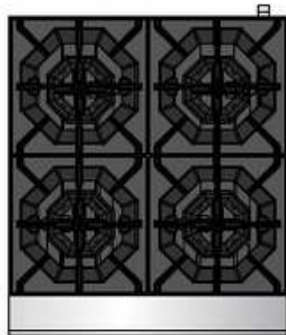
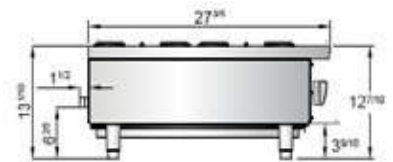
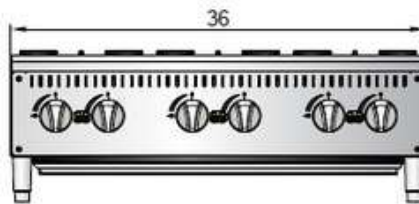
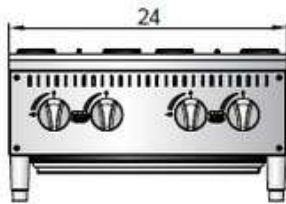

Heavy duty burners

Heavy duty cast iron top grates

Stainless steel knobs

Stainless steel legs



MCK Equipment  
[mckonline.ca](http://mckonline.ca)

**Please be informed:** Product specifications or design are subject to change without notice. Notify any special requirement to your sales representative.



Toll free +1 (833) 978 8833  
 sales@mckequipment.ca  
 Visit [mckonline.ca](http://mckonline.ca) for more details

Quality Kitchen  
 Equipment & Supplies



# Single & Double Stock Pot Stoves

MCK-SP-1 | MCK-SP-2

## FEATURES

- Stainless steel sides and front valve cover
- Full width, removable stainless steel drip pan for easy cleanup
- Heavy duty cast iron top grates
- Heavy duty cast iron three-ring burner, rated at a total of 80,000 BTU/hr
- Cast iron burners and top grates
- Stainless steel tubing for pilots and pilot tips per burner ring
- Each burner is equipped with two continuous pilots
- Two manual controls to operate the inner and outer rings independently
- Stainless steel legs standard
- 3/4" NPT rear gas connection and regulator standard
- With LP conversion kit



**MCK-SP-1**



**MCK-SP-2**





Toll free +1 (833) 978 8833  
 sales@mckequipment.ca  
 Visit [mckonline.ca](http://mckonline.ca) for more details

Quality Kitchen  
 Equipment & Supplies



## SPECIFICATIONS

Model	Door	Gas Type	Intake Tube Pressure (in. W.C.)	Per BTU B.T.U/h	Total BTU B.T.U/h	Regulator	Exterior Dimensions (inch)	Net Weight (lbs)	Gross Weight (lbs)
MCK-SP-1	2 Burners, Independent Manual Control	NG	4	90,000	180,000	4" w.c	18 x 20 9/10 x 22 4/5	106	119
		LP	10	50,000	100,000	10" w.c			
MCK-SP-2	4 Burners, Independent Manual Control	NG	4	90,000	360,000	4" w.c	18 x 41 7/10 x 22 4/5	202	222
		LP	10	80,000	320,000	10" w.c			

## PLAN VIEW

MCK-SP-1

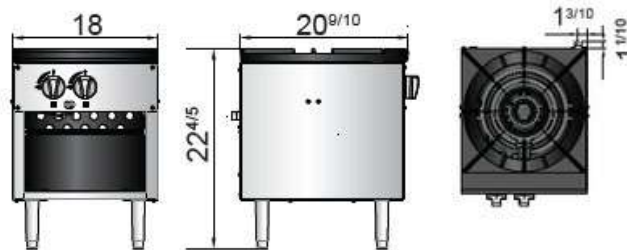

MCK-SP-2

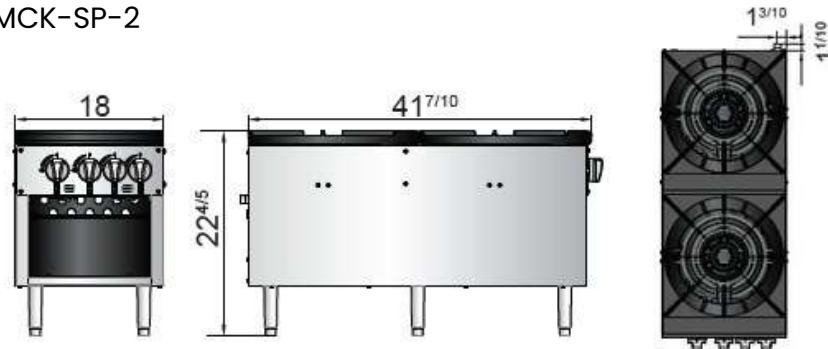

Heavy duty  
burners



Stainless steel  
legs



Cast iron top  
grates



Stainless steel  
knobs



Stainless steel  
drip pan





Toll free +1 (833) 978 8833  
sales@mckequipment.ca  
Visit [mckonline.ca](http://mckonline.ca) for more details



# **GAS RANGES**

Gas Ranges  
(4, 6, 8 & 10 burner models)  
Gas Ranges with Griddle Tops  
36" Combination Gas Ranges  
60" Combination Gas Ranges



Toll free +1 (833) 978 8833  
 sales@mckequipment.ca  
 Visit [mckonline.ca](http://mckonline.ca) for more details

Quality Kitchen  
 Equipment & Supplies



# Gas Ranges (4, 6, 8 & 10 Burner models)

MCK-R4B | MCK-R6B | MCK-R8B | MCK-R10B

## FEATURES

- Stainless steel exterior including front, back sides, kick plate, back guard and over shelf
- Heavy duty 12 inch X 12 inch removable, cast iron top grates
- Drip tray provided under burners to catch grease drippings
- 32,000 BTU top burners and 27,000 BTU oven burners
- Oven temperature range between 175 degrees F to 550 degrees F
- Standing pilot for open top burners
- Oven pilot with 100% safety shut off
- Enamel interior oven for easy cleaning
- Multiple position oven rack guides
- Two (2) chrome oven rack per oven standard
- Available in Natural and Propane
- 3/4 inch NPT rear gas connection and regulator provided
- Four (4) casters standard
- With LP conversion kit



MCK-R4B



MCK-R6B



MCK-R8B



MCK-R10B





Toll free +1 (833) 978 8833  
 sales@mckequipment.ca  
 Visit [mckonline.ca](http://mckonline.ca) for more details

Quality Kitchen  
 Equipment & Supplies



## SPECIFICATIONS

Model	Gas Type	Burner Name	Total BTU B.T.U./h	# of Burners	Valve Types	Oven Size (inch)	Hot Plates Working Area (inch)	Exterior Dimensions (inch)	Net Weight (lbs)	Gross Weight (lbs)
MCK-R4B	NG	Hot plates	128,000	4	Pilot Light	20 x 26 x 14	4 pcs 11 4/5 x 11 4/5	24 x 31 x 57 3/8	326	428
		Oven	24,000	1						
	LP	Hot plates	92,000	4						
		Oven	24,000	1						
MCK-R6B	NG	Hot plates	192,000	6		26 1/2 x 26 x 14	6 pcs 11 4/5 x 11 4/5	36 x 31 x 57 3/8	440	568
		Oven	27,000	1						
	LP	Hot plates	192,000	6						
		Oven	27,000	1						
MCK-R8B	NG	Hot plates	256,000	8		20 x 26 x 14	8 pcs 11 4/5 x 11 4/5	48 x 31 x 57 3/8	607	765
		Oven	48,000	2						
	LP	Hot plates	256,000	8						
		Oven	48,000	2						
MCK-R10B	NG	Hot plates	320,000	10	26 1/2 x 26 x 14	10 pcs 11 4/5 x 11 4/5	60 x 31 x 57 3/8	732	897	
		Oven	54,000	2						
	LP	Hot plates	230,000	10						
		Oven	54,000	2						

## PLAN VIEW

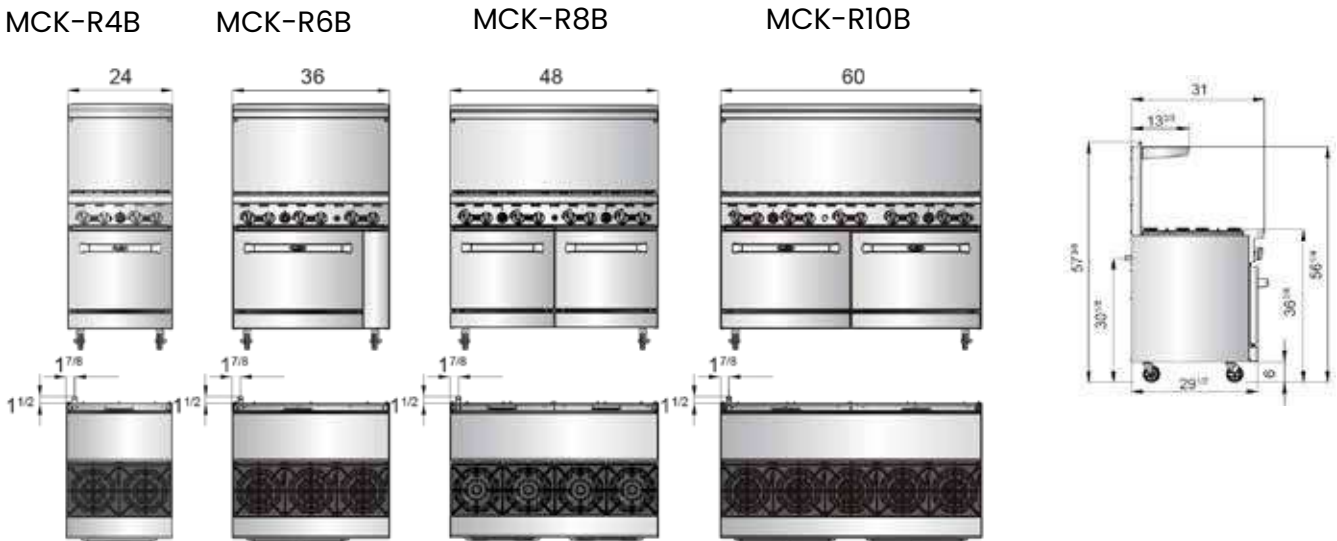

Heavy duty burners



Chrome oven rack



Stainless steel knobs





Toll free +1 (833) 978 8833  
 sales@mckequipment.ca  
 Visit [mckonline.ca](http://mckonline.ca) for more details

Quality Kitchen  
 Equipment & Supplies



# Gas Ranges with Griddle Tops

MCK-RGR24-GT | MCK-RGR36-GT

## FEATURES

- Stainless steel exterior including front, back sides, kick plate, back guard and over shelf
- Heavy duty 3/4" thick polished steel griddle plate
- Drip tray provided under burners to catch grease drippings
- 27,000 BTU griddles & 27,000 BTU oven burners
- Oven temperature range between 175°F to 550°F
- Standing pilot for open top burners
- Oven pilot with 100% safety shut off
- Enamel interior oven for easy cleaning
- Multiple position oven rack guides
- Two(2) chrome oven rack per oven standard
- Available in Natural and Propane
- 3/4" NPT rear gas connection and regulator provided
- Four(4) casters standard
- With LP conversion kit



**MCK-RGR24-GT**



**MCK-RGR36-GT**





Toll free +1 (833) 978 8833  
 sales@mckequipment.ca  
 Visit [mckonline.ca](http://mckonline.ca) for more details



### SPECIFICATIONS

Model	Gas Type	Burner Name	Total BTU B.T.U./h	# of Burners	Valve Types	Oven Size (inch)	Griddle Working Area (inch)	Exterior Dimensions (inch)	Net Weight (lbs)	Gross Weight (lbs)
MCK-RGR24-GT	NG	Griddle	48,000	2	Pilot Light	20 x 26 x 14	24 x 20 5/8	24 x 31 x 57 3/8	367	469
		Oven	24,000	1						
	LP	Griddle	48,000	2						
		Oven	24,000	1						
MCK-RGR36-GT	NG	Griddle	75,000	3	Pilot Light	26 1/2 x 26 x 14	36 x 20 5/8	36 x 31 x 57 3/8	494	622
		Oven	27,000	1						
	LP	Griddle	75,000	3						
		Oven	27,000	1						

### PLAN VIEW

MCK-RGR24-GT

MCK-RGR36-GT

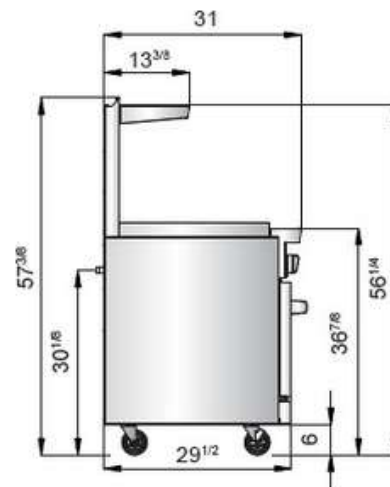

Dripping hole



Stainless steel drip tray



Stainless steel knobs



Stainless steel legs





Toll free +1 (833) 978 8833  
 sales@mckequipment.ca  
 Visit [mckonline.ca](http://mckonline.ca) for more details

Quality Kitchen  
 Equipment & Supplies



# 36" Combination Gas Ranges

MCK-R4B12G | MCK-R2B24G

## FEATURES

- Stainless steel exterior including front, back, sides, kick plate, back guard, and over shelf
- 36" combination ranges with either a 12" or 24" griddle top with 2 or 4 burners
- Heavy duty 3/4" thick polished steel griddle plate
- Drip tray provided under burners to catch grease drippings
- 32,000 BTU top burners, 27,000 BTU griddle, & 27,000 BTU oven burners
- Oven temperature range between 175°F to 550°F
- Standing pilot for open top burners
- Oven pilot with 100% safety shut off
- Enamel interior oven for easy cleaning
- Multiple position oven rack guides
- Two (2) chrome oven racks per oven standard
- Available in Natural Gas or Propane
- 3/4" NPT rear gas connection and regulator provided
- Four (4) casters standard
- With LP conversion kit



**MCK-R4B12G**



**MCK-R2B24G**



Intertek



Intertek



Intertek



Toll free +1 (833) 978 8833  
 sales@mckequipment.ca  
 Visit [mckonline.ca](http://mckonline.ca) for more details

Quality Kitchen  
 Equipment & Supplies



## SPECIFICATIONS

Model	Gas Type	Burner Name	Total BTU B.T.U./h	# of Burners	Valve Types	Oven Size (inch)	Hot Plates Working Area (inch)	Griddle Working Area (inch)	Exterior Dimensions (inch)	Net Weight (lbs)	Gross Weight (lbs)
MCK-R4B12G	NG	Hot Plates	64,000	2	Pilot Light	26 1/2 x 26 x 14	2pcs 11 4/5 x 11 4/5	24 x 20 3/8	36 x 31 x 57 3/8	479	607
		Griddle Oven	48,000	2							
		Hot Plates	24,000	1							
	LP	Griddle Oven	46,000	2							
		Hot Plates	48,000	2							
		Griddle Oven	27,000	1							
MCK-R2B24G	NG	Hot Plates	128,000	4	Pilot Light	26 1/2 x 26 x 14	4pcs 11 4/5 x 11 4/5	12 x 20 3/8	36 x 31 x 57 3/8	462	590
		Griddle Oven	21,000	1							
		Hot Plates	27,000	1							
	LP	Griddle Oven	92,000	4							
		Hot Plates	21,000	1							
		Griddle Oven	27,000	1							

## PLAN VIEW

MCK-R4B12G | MCK-R2B24G

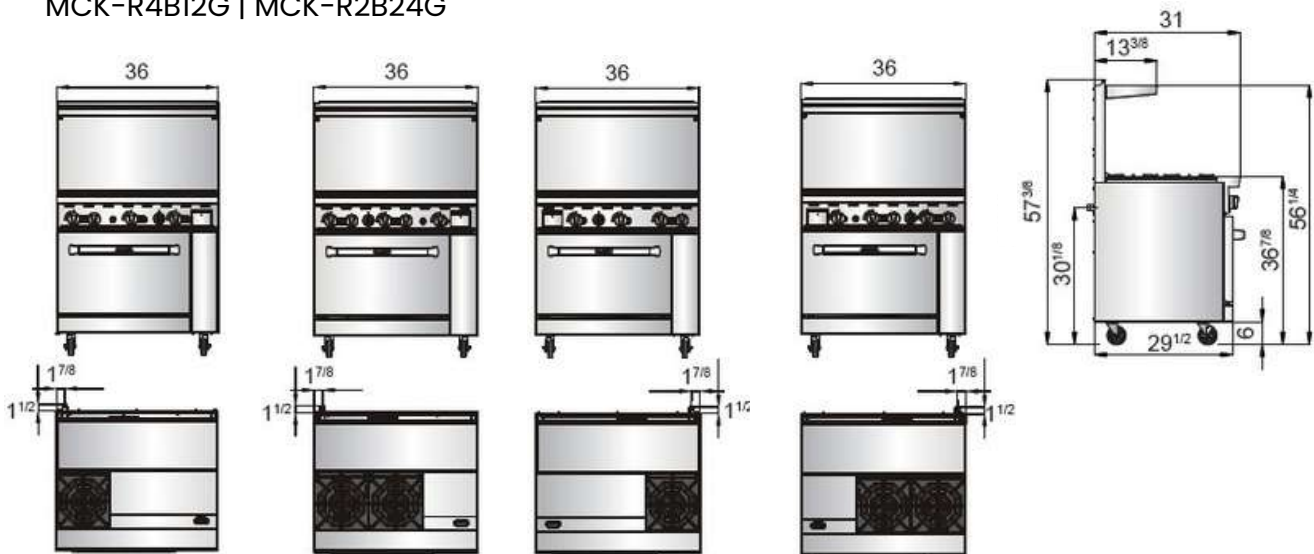

Dripping hole



Stainless steel drip tray



Stainless steel knobs



Stainless steel drip tray





# 60" Combination Gas Ranges

## FEATURES:

- Stainless steel exterior including front, back, sides, kick plate, back guard, and over shelf
- 60" combination ranges standard with either a 24", 36" or 48" griddle top with 2, 4 or 6 burners
- Heavy duty 3/4" thick polished steel griddle plate
- Drip tray provided under burners to catch grease drippings
- 32,000 BTU top burners, 27,000 BTU griddle & 27,000 BTU oven burners
- Oven temperature range between 175°F to 550°F
- Standing pilot for open top burners
- Oven pilot with 100% safety shut off
- Enamel interior oven for easy cleaning
- Multiple position oven rack guides
- Two (2) chrome oven racks per oven standard
- Available in Natural and Propane
- 3/4" NPT rear gas connection and regulator provided
- Four (4) casters standard
- With LP konversion kit



**MCK-R6B24G-S**



**MCK-R6B24G**



Toll free +1 (833) 978 8833  
 sales@mckequipment.ca  
 Visit [mckonline.ca](http://mckonline.ca) for more details



**SPECIFICATIONS**

Model	Gas Type	Burner Name	Total BTU	# of Burners	Valve Types	Oven Size (inch)	Hot Plates Working Area (inch)	Griddle Working Area (inch)	Exterior Dimensions (inch)	Net Weight (lbs)	Gross Weight (lbs)
MCK-R6B24 G	NG	Hot Plates	192,000	6	Pilot Light	26 1/2 x26x14	6 pcs 11 4/5x11 4/5	24x20 3/8	60x31x 57 3/8	775	941
		Griddle	48,000	2							
		Oven	54,000	2							
MCK-R6B24 G-S	NG	Hot Plates	192,000	6	Pilot Light	26 1/2 x26x14	6 pcs 11 4/5x11 4/5	24x20 3/8	60x31x 57 3/8	775	941
		Griddle	48,000	2							
		Oven	54,000	2							
MCK-R6B24 G	LP	Hot Plates	138,000	6							
		Griddle	48,000	2							
		Oven	54,000	2							
MCK-R6B24 G-S	LP	Hot Plates	138,000	6							
		Griddle	48,000	2							
		Oven	54,000	2							



Toll free +1 (833) 978 8833  
 sales@mckequipment.ca  
 Visit [mckonline.ca](http://mckonline.ca) for more details

Quality Kitchen  
 Equipment & Supplies



PLAN VIEW

MCK-R6B24G | MCK-R6B24G-S

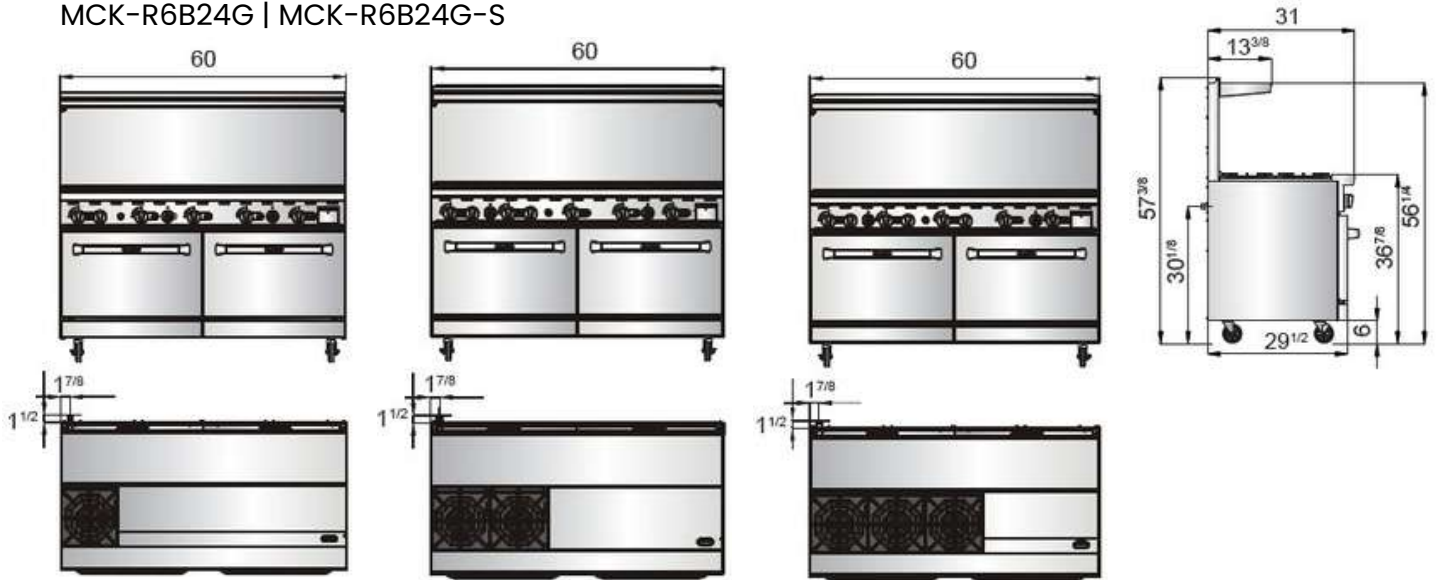

Heavy duty burners



Chrome oven rack



Stainless steel knobs



Stainless steel  
 drip tray





Toll free +1 (833) 978 8833  
sales@mckequipment.ca  
Visit [mckonline.ca](http://mckonline.ca) for more details



## **CHEESE MELTER AND SALAMANDER BROILER**

36" Infrared Cheese Melter  
(Range mount or wall mount)  
36" Infrared Salamander Broiler  
(Range mount or wall mount)



Toll free +1 (833) 978 8833  
 sales@mckequipment.ca  
 Visit [mckonline.ca](http://mckonline.ca) for more details

Quality Kitchen  
 Equipment & Supplies



# 36" Infrared Cheese Melter

MCK-GD-RCM-36

## FEATURES

- Range Mount or Wall Mount
- Stainless steel exterior and interior
- Dual valve controls for left and right-side independent operation
- Two (2) 21,500 BTU high efficiency ceramic infrared burners
- Standby pilots totals 43,000 BTU's
- Removable broiler rack
- Removable crumb catcher
- Range mount kit ships with cheesemelter
- With LP conversion kit



MCK-GD-RCM-36

## OTHER ACCESSORIES

- Wall mount brackets





Toll free +1 (833) 978 8833  
 sales@mckequipment.ca  
 Visit [mckonline.ca](http://mckonline.ca) for more details



## SPECIFICATIONS

Model	Shelves	Type	Gas Intake- Tube Pressure (in.W.C.)	Per BTU B.T.U./H	Total BTU B.T.U./H	Regulator	Exterior Dimensions (inch)	Net Weight (lbs)	Gross Weight (lbs)
MCK-GD-RCMN-36	2 Burners Independent Manual Control	NG	5	15,000	30,000	5" w.c.	36 x 18 x 17 1/3	130	170
		LP	10	15,000	30,000	10" w.c.			

## PLAN VIEW

MCK-GD-RCM-36

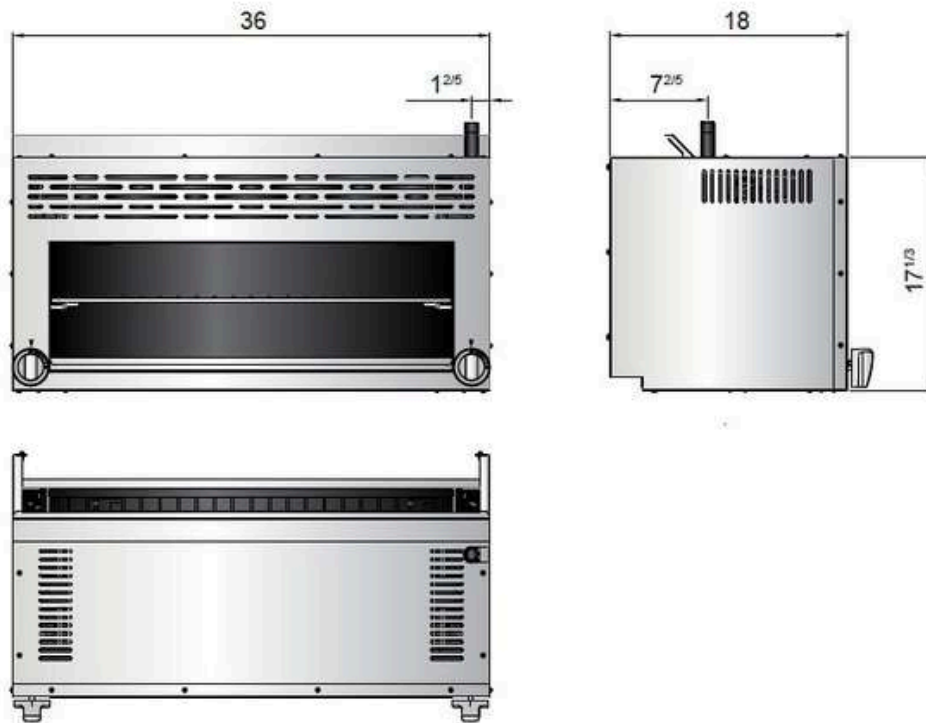

Stainless steel knobs



Stainless steel exterior



Wall mounts



Broiler rack





Toll free +1 (833) 978 8833  
 sales@mckequipment.ca  
 Visit [mckonline.ca](http://mckonline.ca) for more details

Quality Kitchen  
 Equipment & Supplies



# 36" Infrared Salamander Broiler

MCK-GD-RCM-36L

## FEATURES

- Range Mount or Wall Mount
- Stainless steel exterior and interior
- Dual valve controls for left and right-side independent operation
- Two (2) 21,500 BTU high efficiency ceramic infrared burners and standby pilots – totals 43,000 BTU's
- 1 minute pre-heat time
- 4 position rack adjustments on salamander broiler
- One (1) removable broiler chrome rack
- Removable crumb/grease tray
- Range mount kit ships with salamander broiler
- With LP conversion kit



## OTHER ACCESSORIES

- Wall mount brackets

MCK-GD-RCM-36L





Toll free +1 (833) 978 8833  
 sales@mckequipment.ca  
 Visit [mckonline.ca](http://mckonline.ca) for more details

Quality Kitchen  
 Equipment & Supplies



## SPECIFICATIONS

Model	Burners	Gas Type	Intake-Tube Pressure (in.W.C.)	PerBTU B.T.U./H	Total BTU B.T.U./H	Regulator	Exterior Dimensions (inch)	Net Weight (lbs)	Gross Weight (lbs)
MCK-GD-RCM-36L	2 Burners Independent Manual Control	NG	5	21,500	43,000	5"w.c.	36 x 18 x 17 1/3	143	169
		LP	10	21,500	43,000	10"w.c.			

## PLAN VIEW

MCK-GD-RCM-36L

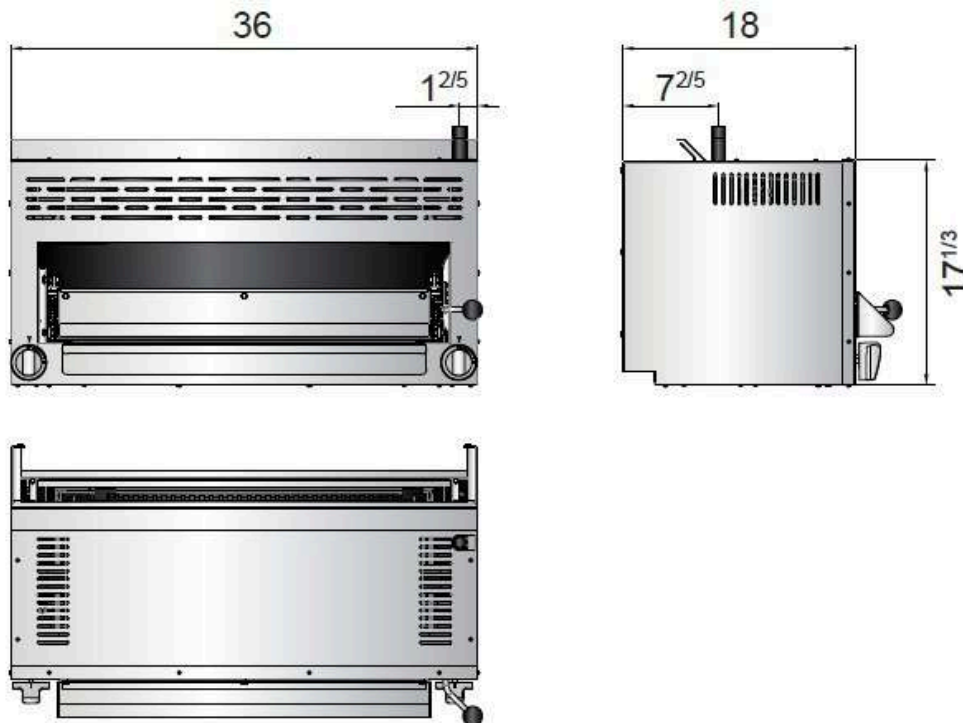

Stainless steel exterior



Crumb/grease tray



Stainless steel knobs



Broiler chrome rack



4 position controller





Toll free +1 (833) 978 8833  
sales@mckequipment.ca  
Visit [mckonline.ca](http://mckonline.ca) for more details



## **FRYERS**

Digital Control Fryer  
Open Bin Fryer  
40, 50, 75 lb. Fryer  
Fryer Filters



Toll free +1 (833) 978 8833  
 sales@mckequipment.ca  
 Visit [mckonline.ca](http://mckonline.ca) for more details

Quality Kitchen  
 Equipment & Supplies



# Digital Control 50 lb Deep Fryer

MCK-SGF45E | MCK-SGF45EL

## FEATURES

- Digital control gas deep fryer, compatible with natural gas and propane
- Made from durable stainless steel and iron for longevity and easy cleaning
- Each basket holds 5.5L, with an oil tank capacity of 20-23L (50lb)
- Features 3 cast iron burners with a BTU output of 90,000 BTU/h
- Equipped with a pilot ignition system for reliable startup
- Thermostat display in Celsius for precise temperature management
- Free-standing unit with 6" adjustable feet or castors for flexibility in placement
- Perfect for high-volume kitchens requiring efficient and reliable deep frying capabilities
- With LP conversion kit



MCK-SGF45E | MCK-SGF45EL





Toll free +1 (833) 978 8833  
 sales@mckequipment.ca  
 Visit [mckonline.ca](http://mckonline.ca) for more details



### SPECIFICATIONS

Model	Shelves	Gas Type	Oil Tank Capacity	Basket Capacity (each)	Total BTU B.T.U./H	Kw	Dimensions (inch)	Packaging Dimensions (inch)	Gross Weight (lbs)
MCK-SGF45E	3 Burners Digital Control	NG	20-23L/50lb	5.5L	90,000	26.4	15.5 x 32.7 x 45.3	17.7 x 35.2 x 44.2	192
MCK-SGF45EL		LP							

Gas Inlet: 3/4 NPT or R1/2  
 Gas type: Natural/Propane gas

### PLAN VIEW

MCK-SGF45E | MCK-SGF45EL

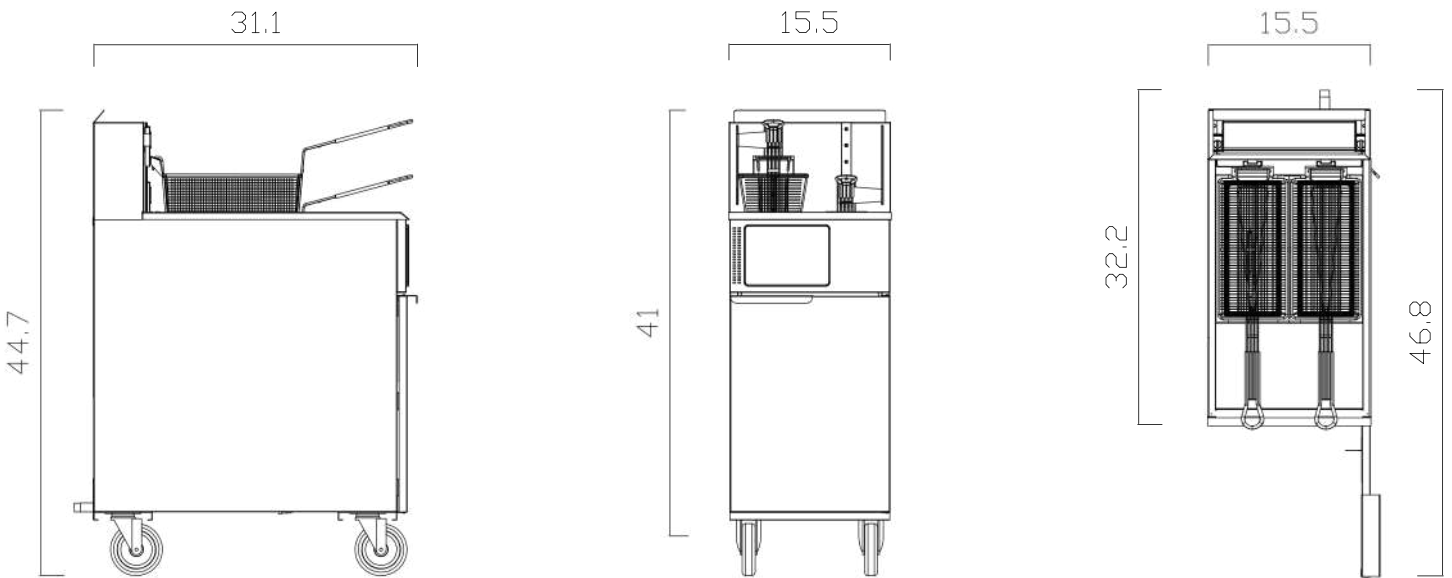

Stainless steel tank



Baskets



Basket hanger



Digital Temperature Control





Toll free +1 (833) 978 8833  
 sales@mckequipment.ca  
 Visit [mckonline.ca](http://mckonline.ca) for more details

Quality Kitchen  
 Equipment & Supplies



# Open Bin 40/50 lb Deep Fryer

MCK-GF120-OB | MCK-GF150-OB |

MCK-PF120-OB | MCK-PF150-OB

## FEATURES

- Holds up to 40 lbs. of oil, ideal for high-volume frying
- The Open Pot Design is easy to clean and maintain, especially for routine daily operations
- Millivolt Control System, ensures easy ignition and consistent heating performance
- Capable of delivering high BTU performance for rapid heating
- Durable, corrosion-resistant build for longevity in commercial environments
- Accurate thermostat for consistent oil temperature regulation
- Reliable pilot ignition system for hassle-free operation
- High-Performance Burners for efficient and even heat distribution
- With LP conversion Kit



MCK-GF150-OB





### SPECIFICATIONS

Model	Design	Gas Type	Oil Tank Capacity	Total BTUs (B.T.U./H)	Frying Area (inch)	Dimensions (inch)	Net Weight (lbs)	Gross Weight (lbs)
MCK-PF120-OB	Open Bin Design	LP	40lb	75,000	14 x 15 x 5	15 5/8 x 30 7/8 x 46 1/8	131	176
MCK-GF120-OB		NG	40lb	100,000	14 x 15 x 5	15 5/8 x 30 7/8 x 46 1/8	131	176
MCK-PF150-OB		LP	50lb	95,000	14 x 15 x 5	15 5/8 x 30 7/8 x 46 1/8	131	176
MCK-GF150-OB		NG	50lb	130,000	14 x 15 x 5	15 5/8 x 30 7/8 x 46 1/8	131	176

### PLAN VIEW

MCK-GF120-OB | MCK-GF150-OB | MCK-PF120-OB | MCK-PF150-OB

Open Bin

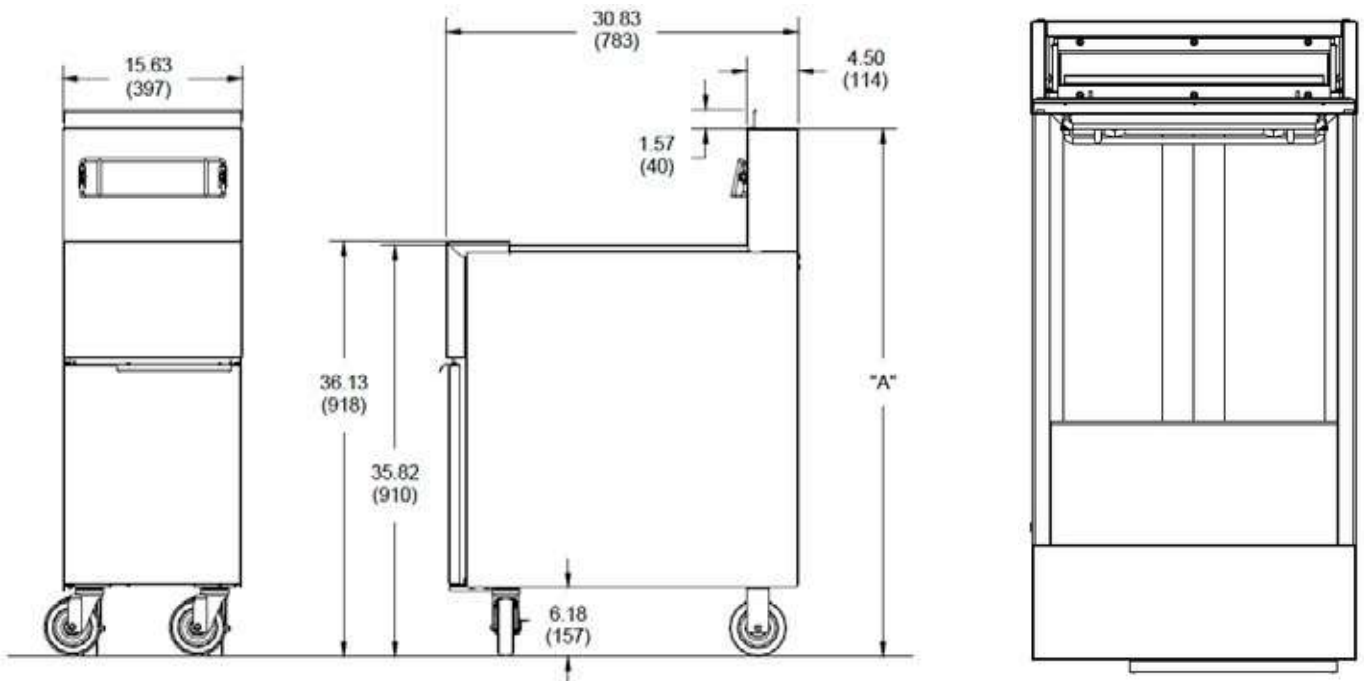

Stainless steel tank



Baskets



Basket hanger



Open Pot





Toll free +1 (833) 978 8833  
 sales@mckequipment.ca  
 Visit [mckonline.ca](http://mckonline.ca) for more details



# Deep Fryers (40, 50, 75lb)

MCK-GF90 | MCK-GF120 | MCK-GF150

## FEATURES

- Stainless steel exterior and interior
- Welded stainless steel tank
- Heavy duty burners with a standing flame, standby pilots
- High quality thermostat maintains select temperature automatically between 200°F-400°F
- Oil cooling zone in the bottom of the tank captures food particles and extends oil life
- Safety valve with an automatic voltage stabilizing function
- Self-reset high temperature limiting device
- Two(2) nickel plated baskets with coated handles standard
- Wire mesh crumb screen and basket hanger standard
- Available in Natural & Propane gas 3/4" NPT rear gas connection and regulator
- Four(4) casters standard
- With leg kit, fryer splash guard and LP Conversion Kit



MCK-GF90



MCK-GF120



MCK-GF150





Toll free +1 (833) 978 8833  
 sales@mckequipment.ca  
 Visit [mckonline.ca](http://mckonline.ca) for more details

Quality Kitchen  
 Equipment & Supplies



## SPECIFICATIONS

Model	Shelves	Gas Type	Intake-Tube Pressure (in.W.C.)	Per BTU B.T.U./H	Total BTU B.T.U./H	Regulator	Basket Dimensions (inch)	Exterior Dimensions (inch)	Net Weight (lbs)	Gross Weight (lbs)
MCK-GF90	3 Burners, Independent Manual Control	NG	4	34,000	100,000	4" w.c.	13 3/10 x 6 1/2 x 5 9/10	15 3/5 x 30 1/10 x 44 2/5	131	160
		LP	10	30,000	90,000	10" w.c.				
MCK-GF120	4 Burners, Independent Manual Control	NG	4	34,000	120,000	4" w.c.	13 3/10 x 6 1/2 x 5 9/10	15 3/5 x 30 1/10 x 44 2/5	143	171
		LP	10	30,000	100,000	10" w.c.				
MCK-GF150	5 Burners, Independent Manual Control	NG	4	34,000	150,000	4" w.c.	13 3/10 x 9 3/10 x 5 9/10	21 1/10 x 30 1/10 x 44 2/5	168	200
		LP	10	30,000	150,000	10" w.c.				

## PLAN VIEW

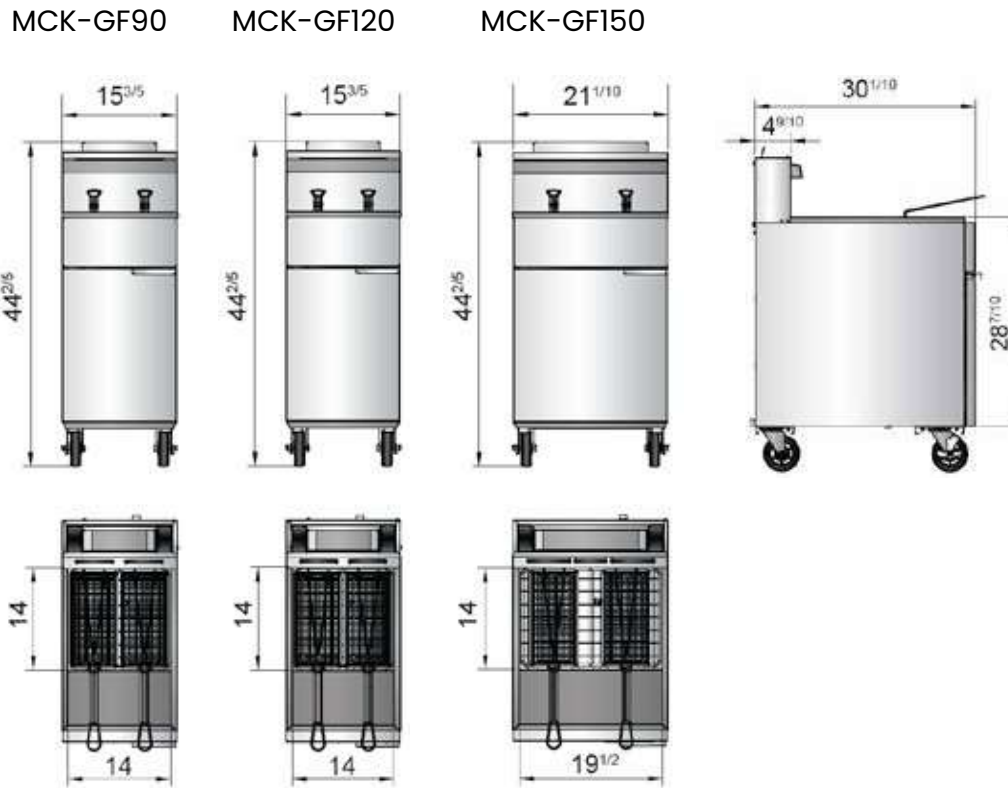

Stainless steel tank

Baskets

Basket hanger

Temperature limiting device





Toll free +1 (833) 978 8833  
 sales@mckequipment.ca  
 Visit [mckonline.ca](http://mckonline.ca) for more details

Quality Kitchen  
 Equipment & Supplies



# Portable Fryer Filter (50-80lb)

MCK-FPOF-50 | MCK-FPOF-80

## FEATURES

- Stainless steel exterior & interior
- Welded steel frame with swivel casters
- 50 lb and 80 lb capacity
- Low profile design for placement under the fryer drain
- Lift-out filter pan for easy cleaning
- Easy to remove filter assembly for easy filter paper replacement
- Reversible heavy duty pump
- Controls: On/Off/Heater
- Pre-installed casters
- 5' flexible, high temperature return hose and wand with heat resistant handle
- Quick-disconnect hose connection makes it easy to assemble
- Includes a filter catch basket and clean out scoop
- With filter paper and LP conversion kit



MCK-FPOF-50



MCK-FPOF-80





Toll free +1 (833) 978 8833  
 sales@mckequipment.ca  
 Visit [mckonline.ca](http://mckonline.ca) for more details



### SPECIFICATIONS

Model	Capacity (lb)	Casters (inch)	Amps (A)	Voltage (V/Hz/Ph)	HP	RPM	Gallons per Min	Exterior Dimensions (inch)	Packing Dimensions (inch)	Net Weight (lbs)	Gross Weight (lbs)
MCK-FFOF-50	50	3	6	115/650/1	1/3	1450	3.43	16 1/4 × 29 1/2 × 24	18 7/8 × 31 7/8 × 29 3/4	81	135
MCK-FFOF-80	80							20 1/4 × 33 1/2 × 24	22 7/8 × 35 7/8 × 29 3/4	97	156

### PLAN VIEW

MCK-FPOF-50

MCK-FPOF-80

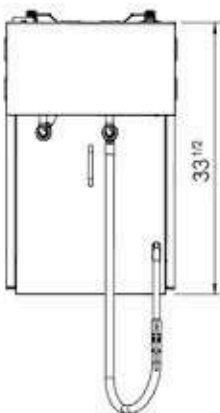
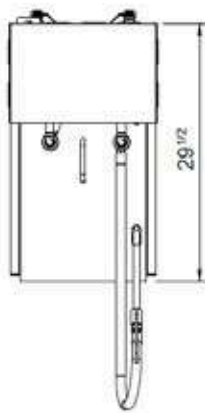
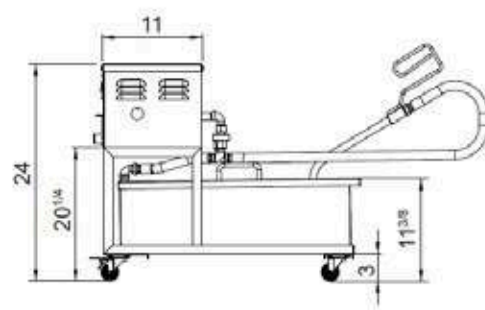
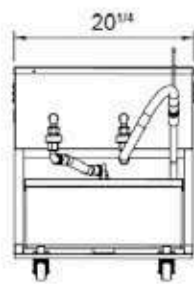
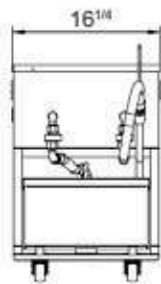

# Ovens

Single | Double Convection  
Gas oven



Toll free +1 (833) 978 8833  
 sales@mckequipment.ca  
 Visit [mckonline.ca](http://mckonline.ca) for more details

Quality Kitchen  
 Equipment & Supplies



# Gas Convection Oven

## FEATURES:

- 29" (Width) x 21.5" (Depth) x 20" (Height)
- 60,000 BTU/hr total
- Temperature range: 150°F to 500°F
- Available in Natural Gas (NG) or Propane (LPG) models
- Four atmospheric burners with air shutters for wide range application
- 1/2 HP two speed fan motor (High: 1710 RPM, Low: 1120 RPM)
- Porcelain enamel lining, seamless interior & corners for easy cleaning
- With LP conversion kit



## MCK-GCO

- 10 position guide rack with 1.5" spacing
- 5 heavy duty adjustable chrome-plated racks
- Trapezoidal leg with casters.





Toll free +1 (833) 978 8833  
 sales@mckequipment.ca  
 Visit [mckonline.ca](http://mckonline.ca) for more details

Quality Kitchen  
 Equipment & Supplies



# Gas Convection Oven Double

**MCK-GCO-D**





Toll free +1 (833) 978 8833  
sales@mckequipment.ca  
Visit [mckonline.ca](http://mckonline.ca) for more details

Quality Kitchen  
Equipment & Supplies



## Construction:

- Top and front constructed with stainless steel for durability and hygiene
- Double pane thermal 5mm thickness glass windows on the doors
- Doors are equipped with an interlock switch that automatically turns the fan off when opened



## SPECIFICATIONS

Model	BTU/HR.	Gas Type	Oven Interior measure	Temperature Range
MCK-GCO	60,000	natural	29"(W) x 21.5"(D) x 20"(H)	150-500F
MCK-GCO	60,000	propane	29"(W) x 21.5"(D) x 20"(H)	150-500F
MCK-GCO-D	60,000	natural	29"(W) x 21.5"(D) x 20"(H)	150-500F
MCK-GCO-D	60,000	propane	29"(W) x 21.5"(D) x 20"(H)	150-500F

## PLAN VIEW

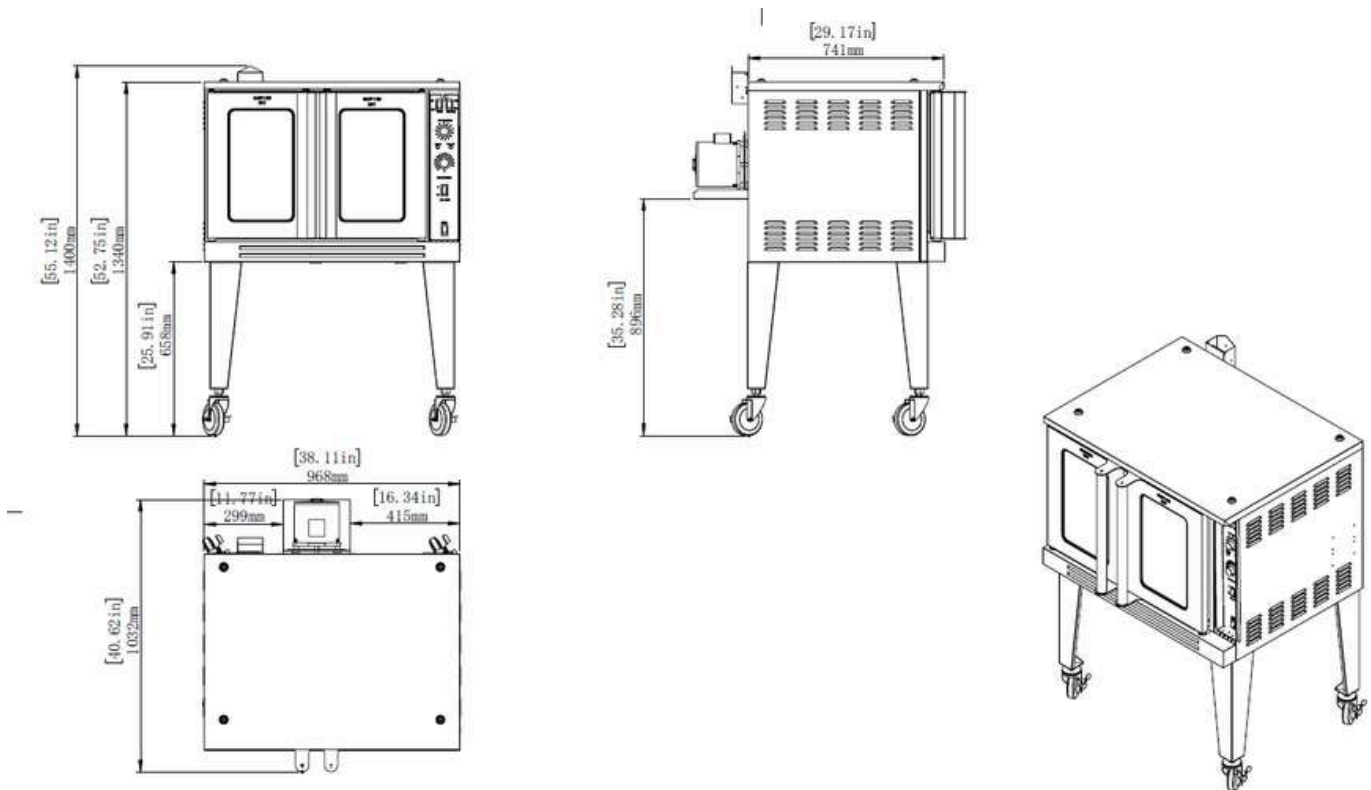



## Detailed Structure

Four atmospheric burners with adjustable air shutters, providing a wide range of application.



Optimized smoke/flue gas routing ensures uniform temperature distribution throughout the chamber.

A three way heat circulation system directs smoke along the sides and rear, pulling it into the cooking chamber through two rear suction ports. This design uses a powerful combination of direct heat and radiant heat from four heated surfaces to guarantee superior and uniform cooking results.

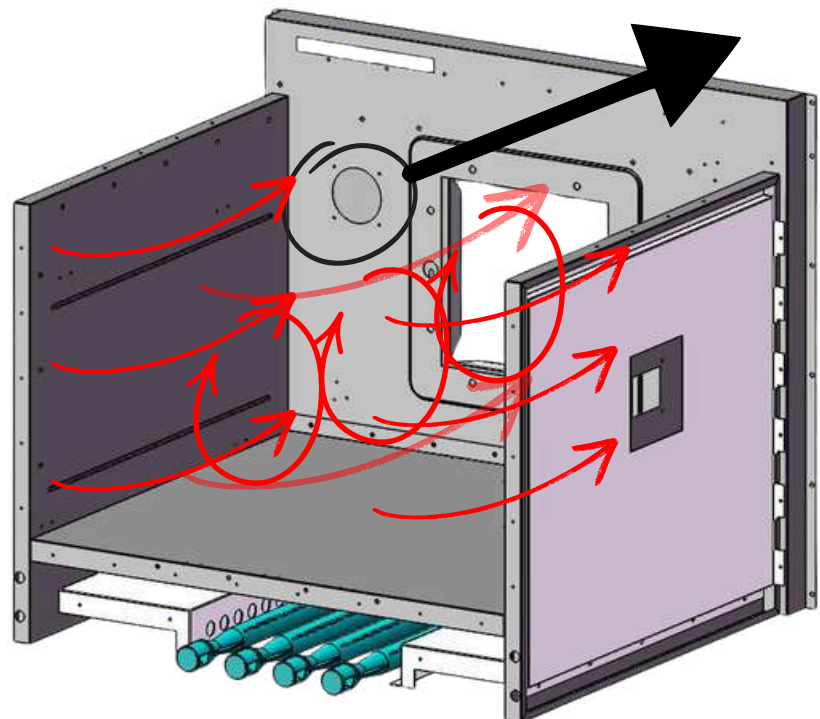



Toll free +1 (833) 978 8833  
sales@mckequipment.ca  
Visit [mckonline.ca](http://mckonline.ca) for more details

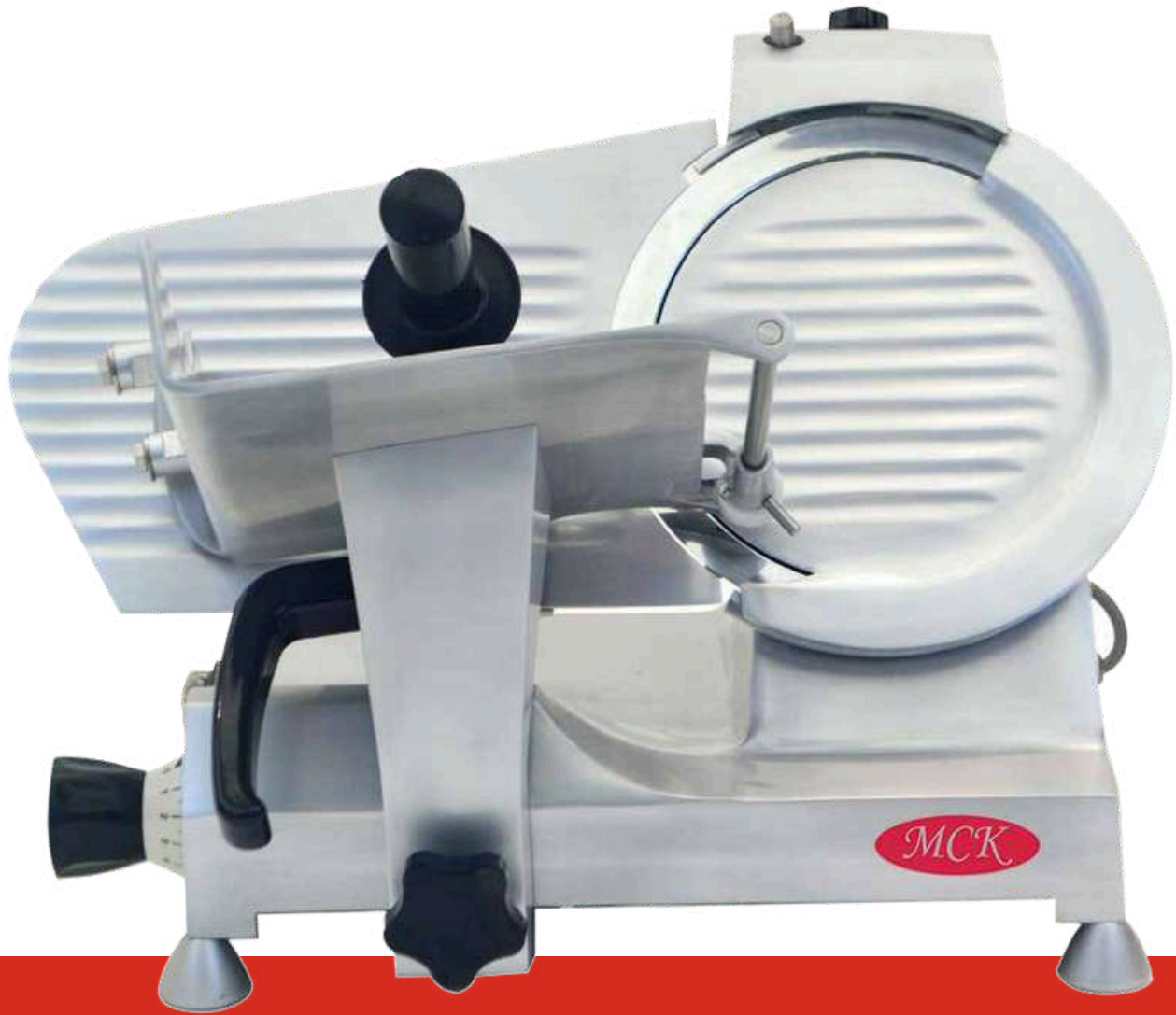

## **SLICERS**

10" Compact Manual Slicer  
12" Compact Manual Slicer  
12" Heavy Duty Manual Slicer  
14" Heavy Duty Slicer 14"  
Heavy Automatic Slicer



Toll free +1 (833) 978 8833  
 sales@mckequipment.ca  
 Visit [mckonline.ca](http://mckonline.ca) for more details

Quality Kitchen  
 Equipment & Supplies



# 10" Compact Manual Slicer

MCK-GD-HBS-250

## FEATURES

- 10" special alloy knife (Rasspe<sup>e</sup>, high quality brand made in Italy), longer lasting and easier to sharpen 1/4 HP knife
- motor with permanently lubricated ball bearings, overload protection Aluminum alloy one-piece base with stain resistant and easy clean anodized finish Top mounted, removable all metal knife sharpener with two stones for a razor sharp cutting edge Index knob control gets 0 to 9/16" (14 mm) precision slice thickness adjustment
- Permanent ring guard protects entire nonslicing portion of the knife, with removable cover and deflector Knife cover interlock prevents slicer from operating without knife cover in place
- Sealed splash zones for added sanitation and protection of electronics
- Angled gravity feed food chute
- Power switch secures no voltage release preventing inadvertent reactivation of slicer in the event of power or interlock interruption
- High quality aluminum base, food chute and feet



MCK-GD-HBS-250





Toll free +1 (833) 978 8833  
 sales@mckequipment.ca  
 Visit [mckonline.ca](http://mckonline.ca) for more details

## SPECIFICATIONS

Model	HP	Watts (W)	Voltage (V/Hz/Ph)	Amps (A)	Drive Type	Exterior Dimensions (Inch)	Net Weight (lbs)	Gross Weight (lbs)
MCK-GD-HBS-250	1/4	180	110/60/1	1.7	Belt driven	26 1/4 x 20 3/10 x 20 3/4	51	57

## PLAN VIEW

MCK-GD-HBS-250

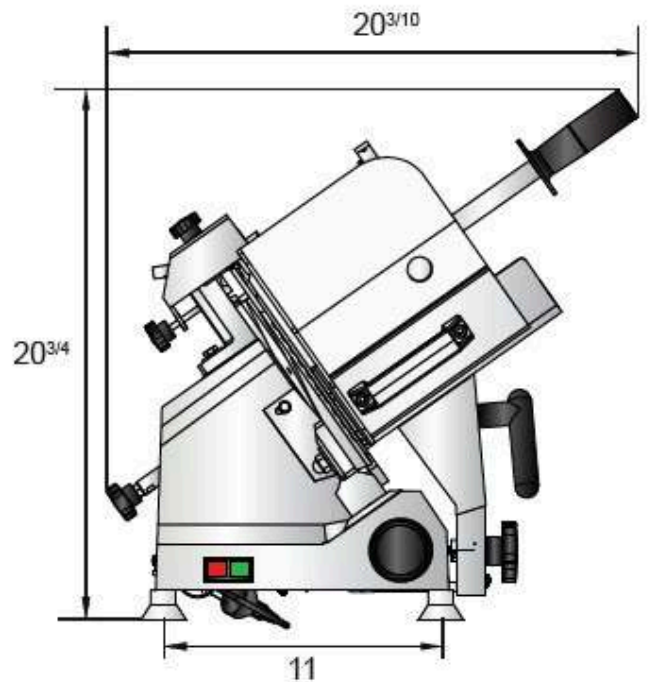
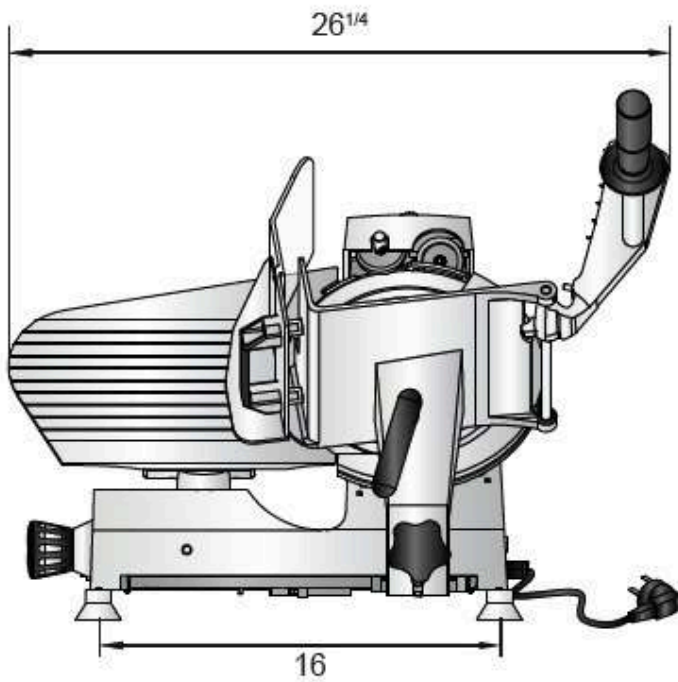

Sealed splash



Indicator light



Metal index knob





Toll free +1 (833) 978 8833  
 sales@mckequipment.ca  
 Visit [mckonline.ca](http://mckonline.ca) for more details

Quality Kitchen  
 Equipment & Supplies



# 12" Compact Manual Slicer

MCK-GD-HBS-300C

## FEATURES

- 12" special alloy knife (Rasspe®, high quality brand made in Italy), longer lasting and easier to sharpen
- 1/3 HP knife motor with permanently lubricated ball bearings, overload protection
- Aluminum alloy one-piece base with stain resistant and easy clean anodized finish
- Top mounted, removable all metal knife sharpener with two stones for a razor sharp cutting edge
- Index knob control gets 0 to 9/16" (14 mm) precision slice thickness adjustment
- Permanent ring guard protects entire non-slicing portion of the knife, with removable cover and deflector
- Knife cover interlock prevents slicer from operating without knife cover in place
- Sealed splash zones for added sanitation and protection of electronics
- Angled gravity feed food chute
- Power switch secures no voltage release preventing inadvertent reactivation of slicer in the event of power or interlock interruption
- High quality anodized aluminum base, food chute and feet



MCK-GD-HBS-300C





Toll free +1 (833) 978 8833  
 sales@mckequipment.ca  
 Visit [mckonline.ca](http://mckonline.ca) for more details

**SPECIFICATIONS**

Model	HP	Watts (W)	Voltage (V/Hz/Ph)	Amps (A)	Drive Type	Exterior Dimensions (Inch)	Net Weight (lbs)	Gross Weight (lbs)
MCK-GD-HBS-300C	1/3	250	110/60/1	2.3	Belt driven	29 1/2 x 22 x 22	62	70

**PLAN VIEW**

MCK-GD-HBS-300C

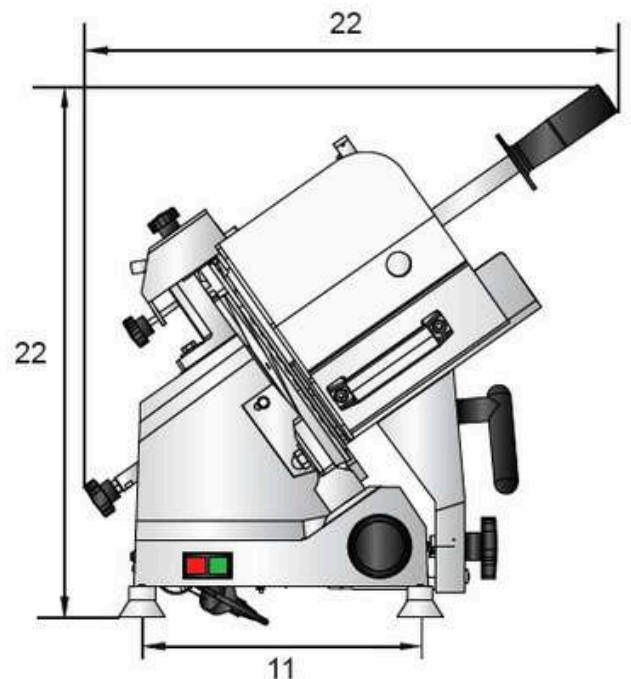
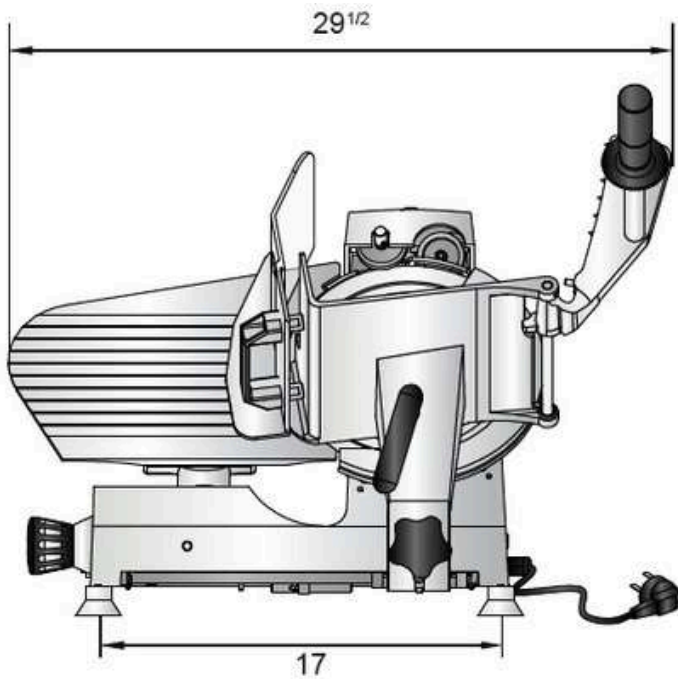

Sealed splash



Indicator light



Metal index knob





Toll free +1 (833) 978 8833  
 sales@mckequipment.ca  
 Visit [mckonline.ca](http://mckonline.ca) for more details

Quality Kitchen  
 Equipment & Supplies



# 12" Heavy Duty Manual Slicer

MCK-GD-HBS-300

## FEATURES

- 12" special alloy knife (Rasspe®, high quality brand made in Italy), longer lasting and easier to sharpen
  - 1/2 HP powerful knife motor with permanently lubricated ball bearings, overload protection
  - Aluminum alloy one-piece base with stain resistant and easy clean anodized finish
  - Top mounted, removable all metal knife sharpener with two stones for a razor sharp cutting edge
  - Index knob control gets 0 to 9/16" (14 mm) precision slice thickness adjustment
  - Permanent ring guard protects entire non-slicing portion of the knife, with removable cover and deflector
  - Knife cover interlock prevents slicer from operating without knife cover in place
  - Sealed splash zones for added sanitation and seamless edges and radius corners
  - Large square food receiving plate
  - Big carriage angle 42°, full gravity feed
  - food chute
- Power switch secures no voltage release preventing inadvertent reactivation of slicer in the event of power or interlock interruption
- High quality aluminum base, food chute and feet



MCK-GD-HBS-300





Toll free +1 (833) 978 8833  
 sales@mckequipment.ca  
 Visit [mckonline.ca](http://mckonline.ca) for more details

### SPECIFICATIONS

Model	HP	Watts (W)	Voltage (V/Hz/Ph)	Amps (A)	Drive Type	Exterior Dimensions (Inch)	Net Weight (lbs)	Gross Weight (lbs)
MCK-GD-HBS-300	1/2	370	110/60/1	3.4	Belt driven	31 1/2 X 20 1/4 X 25	77	86

### PLAN VIEW

MCK-GD-HBS-300

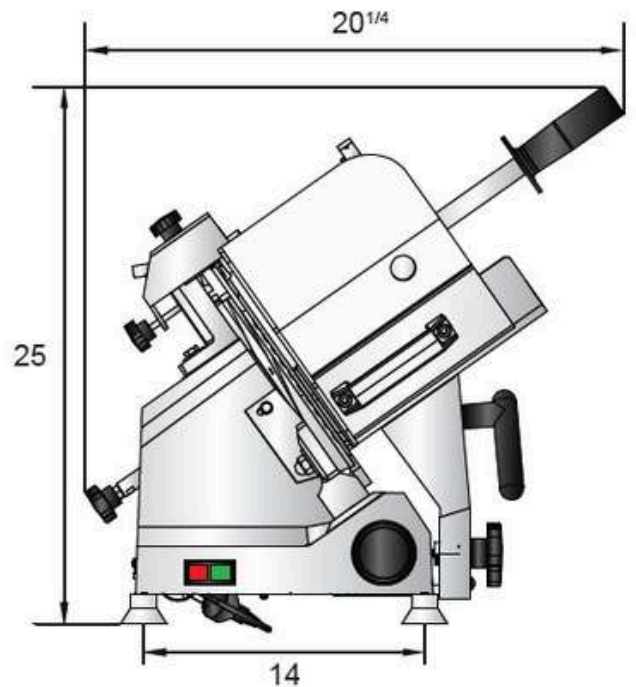
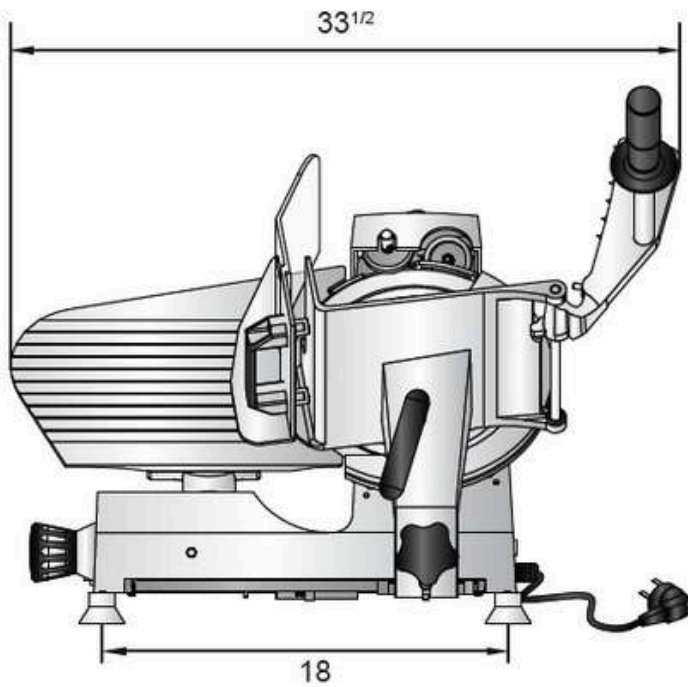

Sealed splash



Indicator light



Metal index knob





Toll free +1 (833) 978 8833  
 sales@mckequipment.ca  
 Visit [mckonline.ca](http://mckonline.ca) for more details

Quality Kitchen  
 Equipment & Supplies



# 14" Heavy Duty Slicer

MCK-GD-HBS-400

## FEATURES

- 14" special alloy knife (Rasspe®, high quality brand made in Italy), longer lasting and easier to sharpen
- 1/2 HP powerful knife motor with permanently lubricated ball bearings, overload protection
- Aluminum alloy one-piece base with stain resistant and easy clean anodized finish
- Top mounted, removable all metal knife sharpener with two stones for a razor sharp cutting edge
- Index knob control gets 0 to 9/16" (14 mm) precision slice thickness adjustment
- Permanent ring guard protects entire non-slicing portion of the knife, with removable cover and deflector
- Knife cover interlock prevents slicer from operating without knife cover in place
- Sealed splash zones for added sanitation and seamless edges and radius corners
- Large square food receiving plate
- Big carriage angle 42°, full gravity feed
- food chute  
 Power switch secures no voltage release preventing inadvertent reactivation of slicer in the event of power or interlock interruption
- High quality aluminum base, food chute and feet



MCK-GD-HBS-400





Toll free +1 (833) 978 8833  
 sales@mckequipment.ca  
 Visit [mckonline.ca](http://mckonline.ca) for more details

### SPECIFICATIONS

Model	HP	Watts (W)	Voltage (V/Hz/Ph)	Amps (A)	Drive Type	Exterior Dimensions (Inch)	Net Weight (lbs)	Gross Weight (lbs)
MCK-GD-HBS-400	1/2	370	110/60/1	3.4	Belt driven	34 1/2 x 23 3/4 x 28 1/2	101	111

### PLAN VIEW

MCK-GD-HBS-400

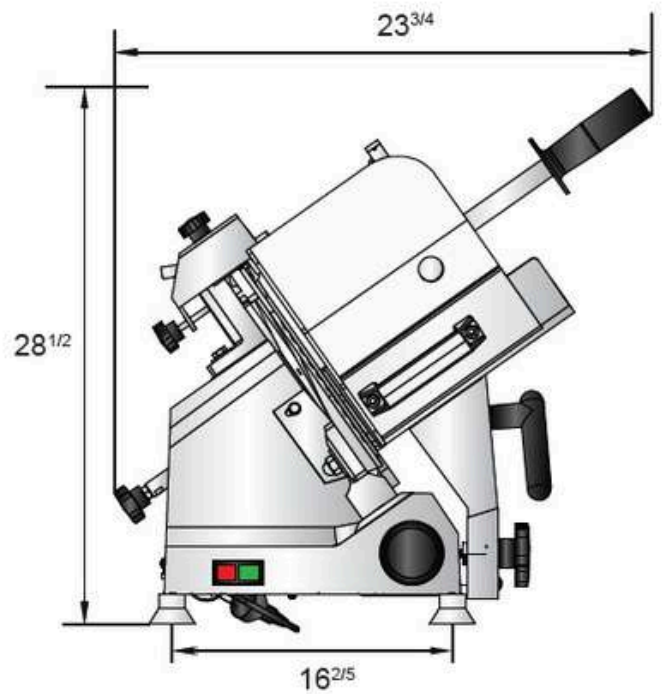
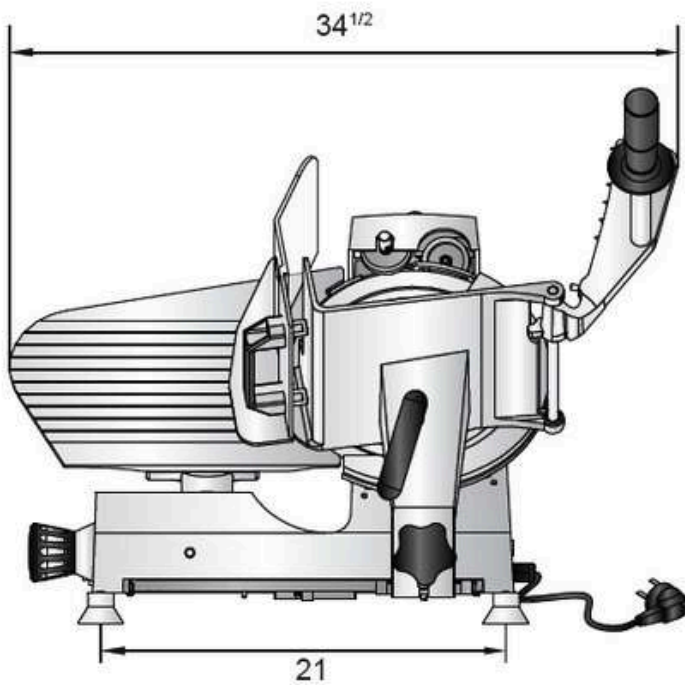

Sealed splash



Indicator light



Metal index knob





Toll free +1 (833) 978 8833  
 sales@mckequipment.ca  
 Visit [mckonline.ca](http://mckonline.ca) for more details

Quality Kitchen  
 Equipment & Supplies



# 14" Heavy Duty Automatic Slicer

MCK-GD-HBS-400A

## FEATURES

- Automatic high precision capacity and cutting, improved with 3 carriage speed and 3 stroke lengths (small-medium-large)
- All functions for slice count, carriage speed control, stroke length control, start/hold/down control are integrated in a digital display and button panel
- Double powerful motors to drive this slicer device, one motor(1/2 HP, 370watts) drives blade, another motor(2/3 HP, 450watts) drives stroke moving
- 14" and 13" special alloy knife (Rasspe@, high quality brand made in Italy), longer lasting and easier to sharpen
- Heavy duty slicer for full capacity at cheese slicing, all day-long duty slicing, slicing volume rate range at 37-62 slices per minute
- Easier switch between automatic slice model to manual slice mode
- High quality reliable structure at base, frame and carriage, include: stainless steel bottom base, anodized aluminum frame base and carriage
- Plastic free structure at this slicer: stainless steel material at index knob, carriage handle and feet
- Top mounted metal knife sharpener with two stones for a razor sharp cutting edge
- High quality stainless steel index knob control gets to 9/16"(14mm) precision slice thickness adjustment
- Knife cover interlock prevents slicer from operating without knife cover in place
- Sealed splash zones for added sanitation and seamless edges and radius corners
- Large square food receiving plate
- Big carriage angle 42°, full gravity feed food chute
- Power switch secures no voltage release preventing inadvertent reactivation of slicer in the event of power or interlock interruption



MCK-GD-HBS-400A





Toll free +1 (833) 978 8833  
 sales@mckequipment.ca  
 Visit [mckonline.ca](http://mckonline.ca) for more details



### SPECIFICATIONS

Model	HP	Watts (W)	Voltage (V/Hz/Ph)	Amps (A)	Drive Type	Exterior Dimensions (Inch)	Gross Weight (lbs)
MCK-GD-HBS-400A	2/3	450	110/60/1	4.6	Belt driven	29 9/10 x 25 2/3 x 27 5/8	111

### PLAN VIEW

MCK-GD-HBS-400A

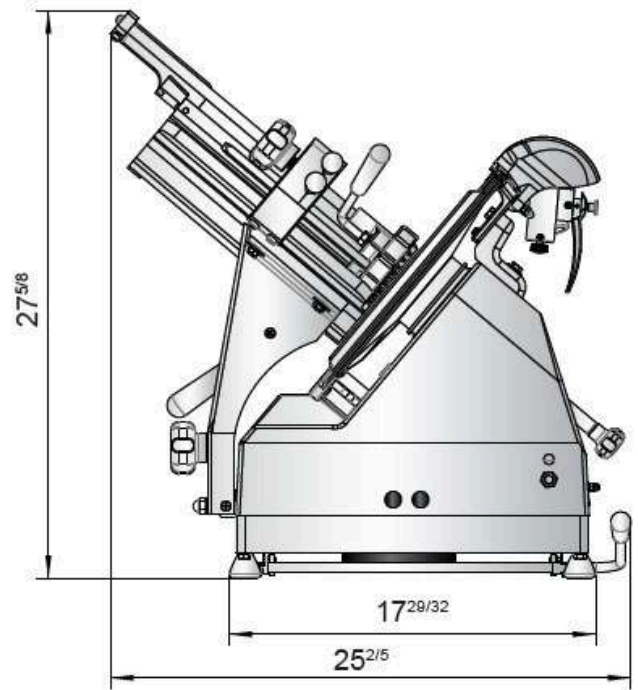
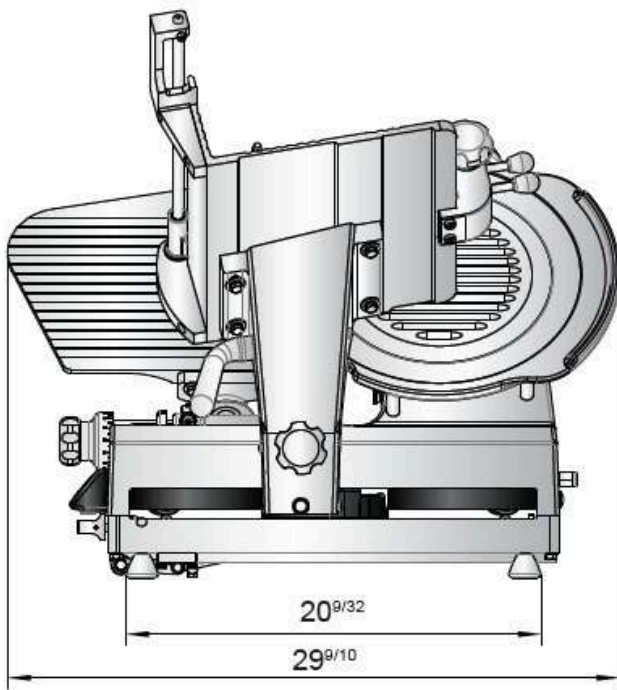

Sealed splash



A-M Switch



Control Panel





Toll free +1 (833) 978 8833  
sales@mckequipment.ca  
Visit [mckonline.ca](http://mckonline.ca) for more details



# MIXERS

Heavy Duty 10, 20, 30, 40 and 60  
Quart Planetary Mixer



Toll free +1 (833) 978 8833  
 sales@mckequipment.ca  
 Visit [mckonline.ca](http://mckonline.ca) for more details

Quality Kitchen  
 Equipment & Supplies



# Heavy Duty 10 Quart Planetary Mixer

MCK-GD-PL10J

## FEATURES

- Three fixed speeds
- Gear driven transmission with aluminum alloy gear box
- 30-minute timer
- Safety cut-switch temporarily interrupts power if gears are changed without stopping the mixer
- Easy to reach controls
- Interlocked bowl lift and stainless-steel bowl guard with swing out bowl
- 6 foot cord with NEMA 5-15 plug
- Steel body with open base



MCK-GD-PL10J

## STANDARD ACCESORY PACKAGE

- Stainless steel bowl
- Stainless steel flat beater
- Stainless steel wire whisk
- Stainless steel spiral dough hook
- Non-slip rubber feet

## OPTIONAL ACCESSORIES

- Flat beater
- Dough hook
- Wire whip
- Extra stainless steel bowl





## SPECIFICATIONS

Model	HP	Watts (W)	Voltage (V/Hz/Ph)	Amps (A)	Capacity (Quarts)	Exterior Dimensions (Inch)	Net Weight (lbs)	Gross Weight (lbs)	Agitator speed		
									First (Low)	Second	Third (High)
MCK-GD-PL10J	1	750	115/60/1	10	10	15 1/2 x 15 1/2 x 24	79	88	108	195	355

## PLAN VIEW

MCK-GD-PL10J

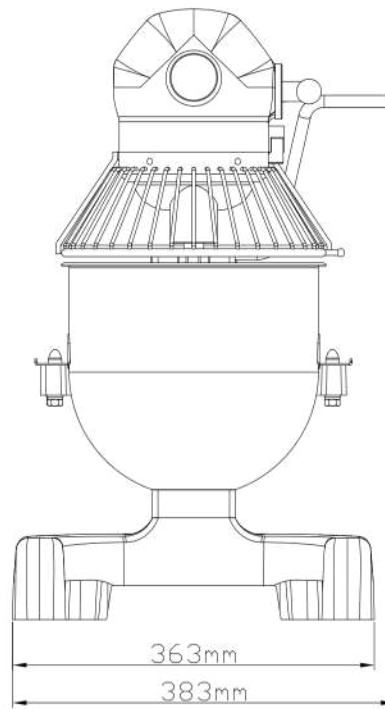
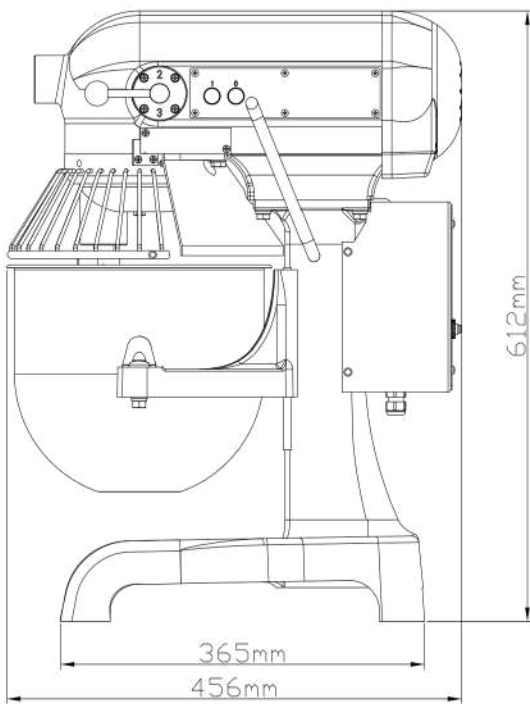

Mixing Bowl



Dough Hook



Wire whip



Flat beater



Controls



Large Capacity Bowl



Cage





Toll free +1 (833) 978 8833  
 sales@mckequipment.ca  
 Visit [mckonline.ca](http://mckonline.ca) for more details

Quality Kitchen  
 Equipment & Supplies



# Heavy Duty 20 Quart Planetary Mixer

MCK-GD-PL20J

## FEATURES

- Three fixed speeds
- Gear driven transmission with aluminum alloy gear box
- 30-minute timer
- Safety cut-switch temporarily interrupts power if gears are changed without stopping the mixer
- Easy to reach controls
- Interlocked bowl lift and stainless-steel bowl guard with swing out bowl
- 6' cord with NEMA 5-15 plug
- Steel body with open base

## STANDARD ACCESORY PACKAGE

- Stainless steel bowl
- Stainless steel flat beater
- Stainless steel wire whisk
- Stainless steel spiral dough hook
- Non-slip rubber feet

## OPTIONAL ACCESSORIES

- Meat grinder for #12 hub
- Slicer/Shredder/Grater for #12 hub



MCK-GD-PL20J

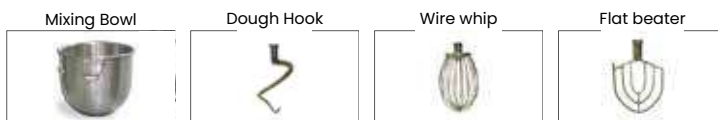



### SPECIFICATIONS

Model	HP	Watts (W)	Voltage (V/Hz/Ph)	Amps (A)	Capacity (Quarts)	Exterior Dimensions (Inch)	Net Weight (lbs)	Gross Weight (lbs)	Agitator speed		
									First (Low)	Second	Third (High)
MCK-GD-PL20J	11/2	1100	115/60/1	14	20	21 3/4 x 21 x 32	211	246	106	180	367

### PLAN VIEW

MCK-GD-PL20J

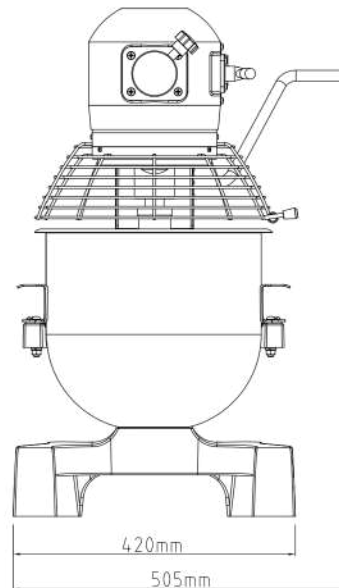
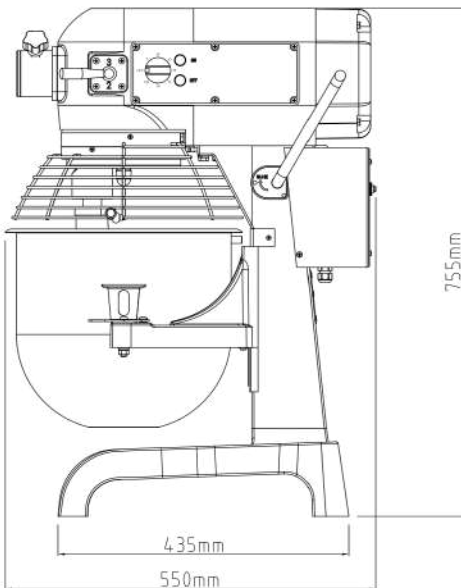

Controls



Large Capacity Bowl



Cage





Toll free +1 (833) 978 8833  
 sales@mckequipment.ca  
 Visit [mckonline.ca](http://mckonline.ca) for more details

Quality Kitchen  
 Equipment & Supplies



# Heavy Duty 30 Quart Planetary Mixer

MCK-GD-PL30J

## FEATURES

- Three fixed speeds
- Gear driven transmission with aluminum alloy gear box
- 30-minute timer
- Safety cut-switch temporarily interrupts power if gears are changed without stopping the mix
- Number 12 hub accomodates meat grinder or shredder attachments for flexibility between grinding and mixing
- Easy to reach controls
- Interlocked bowl lift and stainless-steel bowl guard with swing out bowl
- 6' cord with NEMA 5-15 plug
- Steel body with open base



## STANDARD ACESORY PACKAGE

- Stainless steel bowl
- Stainless steel flat beater
- Stainless steel wire whisk
- Stainless steel spiral dough hook
- Non-slip rubber feet

## OPTIONAL ACCESSORIES

- Meat grinder for #12 hub
- Slicer/Shredder/Grater for #12 hub

Mixing Bowl



Dough Hook



Wire whip



Flat beater



MCK-GD-PL30J

Please confirm your dough and water ration before mixing product. (1) choose correct speed, and (2) correct water ratio, (3) suitable volume for the mix process according to "Mix Capacity Chart" in the MCK manual.

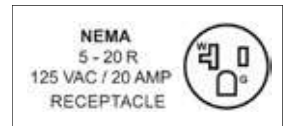



## SPECIFICATIONS

Model	HP	Watts (W)	Voltage (V/Hz/Ph)	Amps (A)	Capacity (Quarts)	Exterior Dimensions (Inch)	Net Weight (lbs)	Gross Weight (lbs)	Agitator speed		
									First (Low)	Second	Third (High)
MCK-GD-PL30J	2	1500	115/60/1	20	30	23 x 24 x 46	374	396	91	166	282

## PLAN VIEW

MCK-GD-PL30J

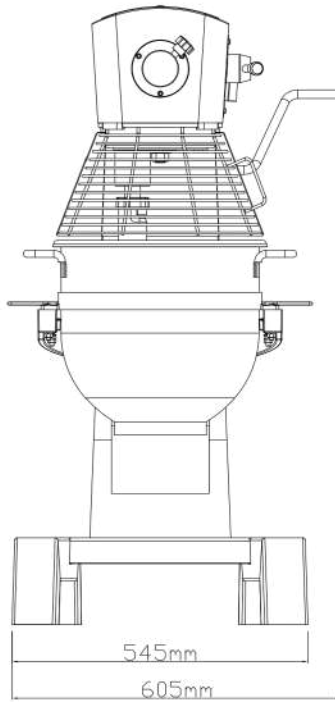
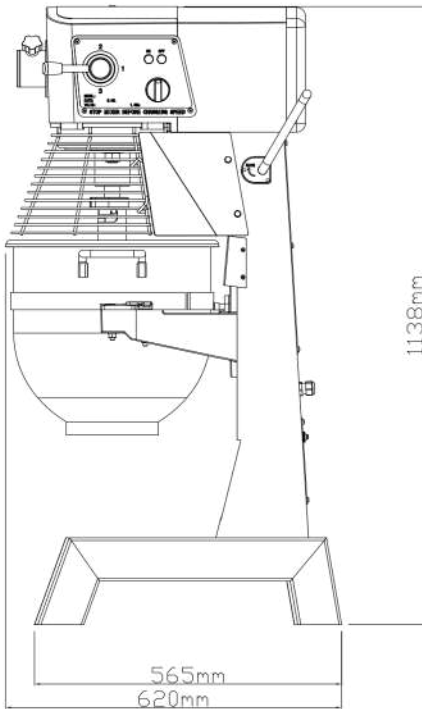

Controls



Large Capacity Bowl



Cage





Toll free +1 (833) 978 8833  
 sales@mckequipment.ca  
 Visit [mckonline.ca](http://mckonline.ca) for more details

Quality Kitchen  
 Equipment & Supplies



# Heavy Duty 40 Quart Planetary Mixer

MCK-GD-PL40J

## FLOOR MODEL FEATURES

- Three fixed speeds
- Gear driven transmission with aluminum alloy gear box
- 30-minute timer
- Safety cut-switch temporarily interrupts power if gears are changed without stopping the mixe
- Number 12 hub accomodates meat grinder or shredder attachments for flexibility between grinding and mixing
- Easy to reach controls
- Interlocked bowl lift and stainless-steel bowl guard with swing out bowl
- 6' cord with NEMA 5-15 plug
- Steel body with open base

## STANDARD ACESORY PACKAGE

- Stainless steel bowl
- Stainless steel flat beater
- Stainless steel wire whisk
- Stainless steel spiral dough hook
- Non-slip rubber feet

## OPTIONAL ACCESSORIES

- Meat grinder for #12 hub
- Slicer/Shredder/Grater for #12 hub



Mixing Bowl



Dough Hook



Wire whip



Flat beater



MCK-GD-PL40J

Please confirm your dough and water ration before mixing product.  
 (1) choose correct speed, and (2) correct water ratio, (3) suitable volume for the mix process according to "Mix Capacity Chart" in the MCK manual.

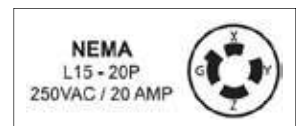



Toll free +1 (833) 978 8833  
 sales@mckequipment.ca  
 Visit [mckonline.ca](http://mckonline.ca) for more details



## SPECIFICATIONS

Model	HP	Watts (W)	Voltage (V/Hz/Ph)	Amps (A)	Capacity (Quarts)	Exterior Dimensions (Inch)	Net Weight (lbs)	Gross Weight (lbs)	Agitator speed			
									First (Low)	Second (1)	Third (2)	Third (High)
MCK-GD-PL40J	3 3/4	2800	240/60/3	15	60	28 x 41 x 57	1078	1190	73	103	143	216

## PLAN VIEW

MCK-GD-PL40J

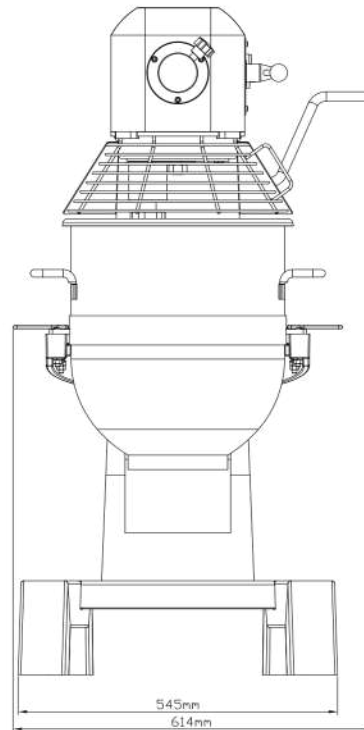
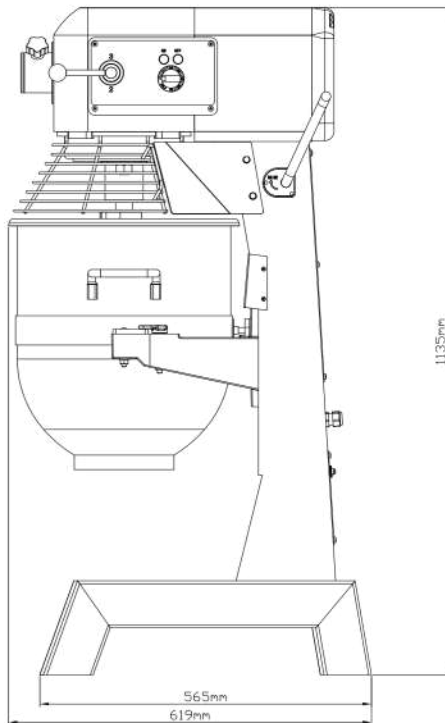

Controls



Large Capacity Bowl



Cage





Toll free +1 (833) 978 8833  
 sales@mckequipment.ca  
 Visit [mckonline.ca](http://mckonline.ca) for more details

Quality Kitchen  
 Equipment & Supplies



# Heavy Duty 60 Quart Planetary Mixer

MCK-GD-PL60J

## FLOOR MODEL FEATURES

- Three fixed speeds
- Gear driven transmission with aluminum alloy gear box
- 30-minute timer
- Safety cut-switch temporarily interrupts power if gears are changed without stopping the mixer
- Number 12 hub accommodates meat grinder or shredder attachments for flexibility between grinding and mixing
- Easy to reach controls
- Interlocked bowl lift and stainless-steel bowl guard with swing out bowl
- 6' cord with NEMA 5-15 plug
- Steel body with open base



## STANDARD ACCESSORY PACKAGE

- Stainless steel bowl
- Stainless steel flat beater
- Stainless steel wire whisk
- Stainless steel spiral dough hook
- Non-slip rubber feet

## OPTIONAL ACCESSORIES

- Meat grinder for #12 hub
- Slicer/Shredder/Grater for #12 hub

Mixing Bowl



Dough Hook



Wire whip



Flat beater



MCK-GD-PL60J

Please confirm your dough and water ration before mixing product.  
 (1) choose correct speed, and (2) correct water ratio, (3) suitable volume for the mix process according to "Mix Capacity Chart" in the MCK manual.

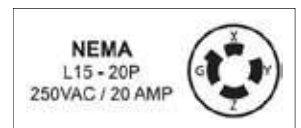



Toll free +1 (833) 978 8833  
 sales@mckequipment.ca  
 Visit [mckonline.ca](http://mckonline.ca) for more details



## SPECIFICATIONS

Model	HP	Watts (W)	Voltage (V/Hz/Ph)	Amps (A)	Capacity (Quarts)	Exterior Dimensions (Inch)	Net Weight (lbs)	Gross Weight (lbs)	Agitator speed			
									First (Low)	Second (1)	Third (2)	Third (High)
MCK-GD-PL60J	3 3/4	2800	240/60/3	15	60	28 x 41 x 57	1078	1190	73	103	143	216

## PLAN VIEW

MCK-GD-PL60J

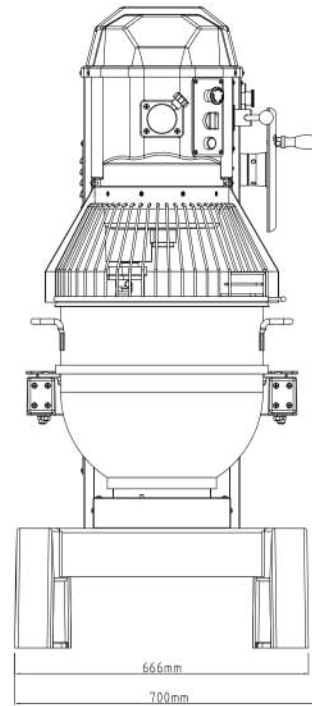
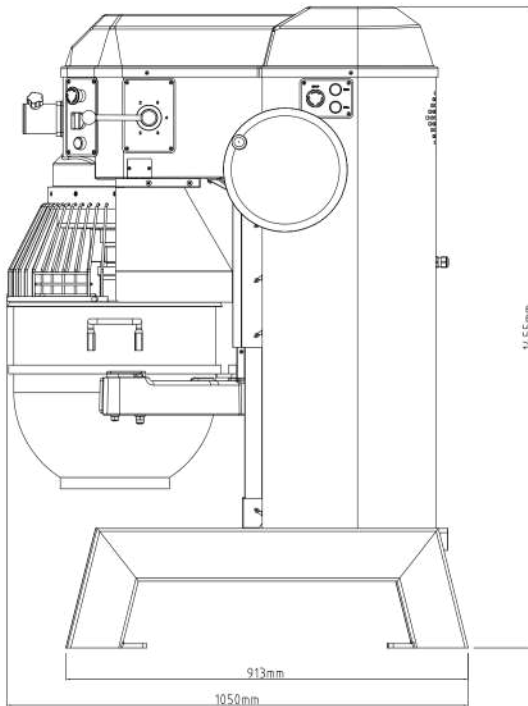

Controls



Large Capacity Bowl



Cage





Toll free +1 (833) 978 8833  
sales@mckequipment.ca  
Visit [mckonline.ca](http://mckonline.ca) for more details



# **CURING CABINETS**

## Meat Agers



Toll free +1 (833) 978 8833  
 sales@mckequipment.ca  
 Visit [mckonline.ca](http://mckonline.ca) for more details

# Meat Ager

MCK-GD-VII20SA

## FEATURES

- Suitable for both built-in and free-standing installation.
- 14 cu ft net capacity, ideal for steak aging.
- Humidity range of 60%-85% and temperature range of 33-77°F for optimal aging conditions.
- Black glass door with 2 layers of LOW-E glass for enhanced insulation.
- Touchpad controller with LED display for easy monitoring and adjustments.
- UVC system and stainless steel humidifier cover to maintain a clean environment.
- White LED light inside for clear visibility.
- Comes with a lock and is CSA certified.
- Fan cooling system powered by a current of 1.9A and uses R600a refrigerant.
- Features a humidification system with an automatic water addition system.

## Accessories:

- Includes 1 stainless steel hanging rod with 3 hangers, 3 stainless steel shelves, and 1 stainless steel salt tray.



MCK-GD-VII20SA





Toll free +1 (833) 978 8833  
 sales@mckequipment.ca  
 Visit [mckonline.ca](http://mckonline.ca) for more details



### SPECIFICATIONS

Model	Capacity	Humidity Range	Temp. Range	Refrigerant	Humidification System	Current	Voltage	Exterior Dimensions (DWH inch)	Package Dimensions (DWH inch)	Net Weight (lbs)	Gross Weight (lbs)
MCK-GD-VII20SA	14 cu. ft.	60-85%	33 - 77°F	R600a	Automatic	1.9A	110-120V 60Hz	27.95 x 23.4 x 50	30.7 x 25.39 x 56.3	150	178.5

### PLAN VIEW

MCK-GD-VII20SA

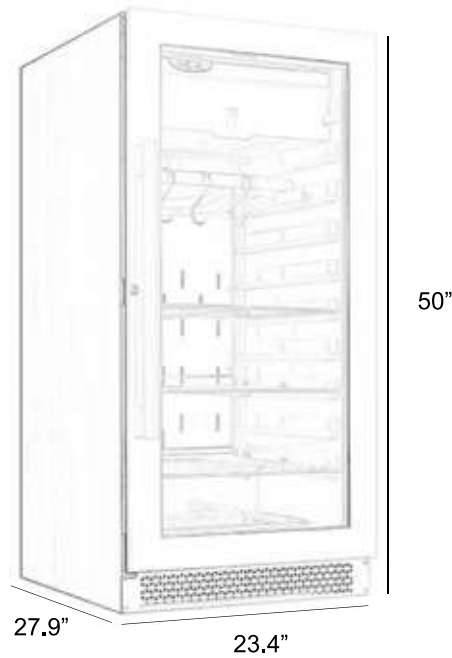

Stainless Steel



Filter



Temperature/  
 humidity control





Toll free +1 (833) 978 8833  
sales@mckequipment.ca  
Visit [mckonline.ca](http://mckonline.ca) for more details



# **PROOFERS**

Insulated Heater/Proofer/Holding  
Cabinets



Toll free +1 (833) 978 8833  
 sales@mckequipment.ca  
 Visit [mckonline.ca](http://mckonline.ca) for more details

Quality Kitchen  
 Equipment & Supplies



# Insulated Heater/Proofer/ Holding Cabinets

MCK-GD-FZ09A | MCK-GD-FZ08A

## FEATURES

- Accommodates up to 36 layers, making it ideal for large-scale operations
- Operates at 1440W with a voltage/frequency of 120V/60Hz
- Aluminum construction for both the cabinet and handle ensures durability
- Features a neutral red mechanical control panel with a PC transparent door
- Equipped with 9 gear settings for both heating and proofing functions
- Includes a NEMA 5-15P power cord, mechanical thermostat, SUS 304 heating element, and grounding for safety
- Fitted with casters for easy movement



MCK-GD-FZ09A



MCK-GD-FZ08A





## SPECIFICATIONS

Model	Shelves	Voltage/ Frequency	Power (W)	Watts	Temp. Control Range (°F)	Heater	Proofer	Capacity (Layers)	Exterior Dimensions (inch)	Net Weight (lbs)	Gross Weight (lbs)
MCK-GD-FZ09A	Heated cabinet (9 pans)	120V/60HZ	1440	2000	80-220	9 Gears		12	25 1/10 x 30 7/10 x 42 7/10	92.81	130.95
MCK-GD-FZ08A	Heated cabinet (18 pans)			2000	80-220			36	25 1/10 x 30 7/10 x 69 7/10		

Rails Fit for 660 x 460 mm sheet pan.

## PLAN VIEW

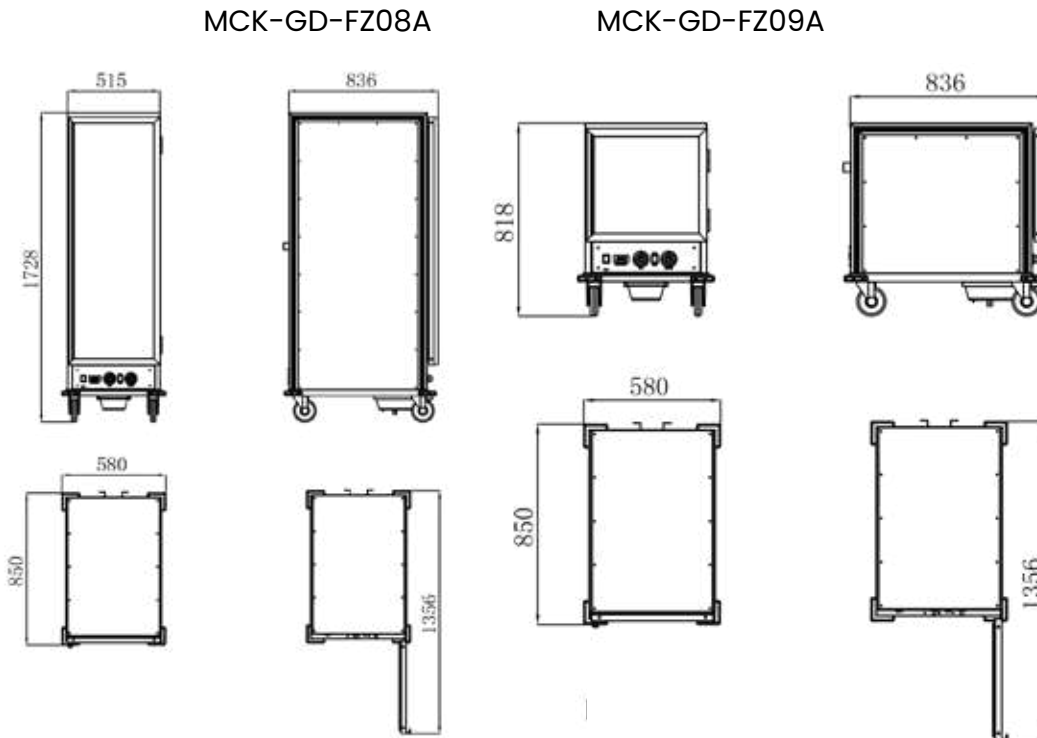

Aluminum Cabinet  
and Handle



Mechanical  
Thermostat



Pan holds





Toll free +1 (833) 978 8833  
sales@mckequipment.ca  
Visit [mckonline.ca](http://mckonline.ca) for more details



# **FOOD PROCESSORS AND BONE SAWS**

Meat Grinders  
Vegetable Chopper  
Bowl Cutter  
Bone Saws  
Immersion Blenders



Toll free +1 (833) 978 8833  
 sales@mckequipment.ca  
 Visit [mckonline.ca](http://mckonline.ca) for more details

Quality Kitchen  
 Equipment & Supplies



# Meat Grinders

MCK-TT-M22HF

## FEATURES

- Powerful, high torque motor, with manual reset overload protection
- Direct gear-driven transmission, mounted on ball bearings
- Permanent grease-lubricated gear box
- Manual reset motor overload protection
- Forward/reverse switch
- Compact size and seamless construction
- 250 - 450 lbs/hr meat capacity
- Top-mounted handle with tray support
- Non-slip rubber feet
- Six-foot cord and plug



## STANDARD ACCESSORIES

- Knife
- Stainless steel product tray
- 1/4" (6mm) plate
- 5/16" (8mm) plate
- Plastic food pusher
- Sausage stuffing tube



MCK-TT-M22HF





Toll free +1 (833) 978 8833  
 sales@mckequipment.ca  
 Visit [mckonline.ca](http://mckonline.ca) for more details

Quality Kitchen  
 Equipment & Supplies



## SPECIFICATIONS

Model	HP	Watts (W)	Voltage (V/Hz/Ph)	Capacity (lbs/h)	Speed (RPMs)	Exterior Dimensions (Inch)	Net Weight (lbs)	Gross Weight (lbs)
MCK-TT-M22HF	1	735	110/60/1	250	170	8 3/5 x 10 x 19	61	68

## PLAN VIEW

MCK-TT-M22HF

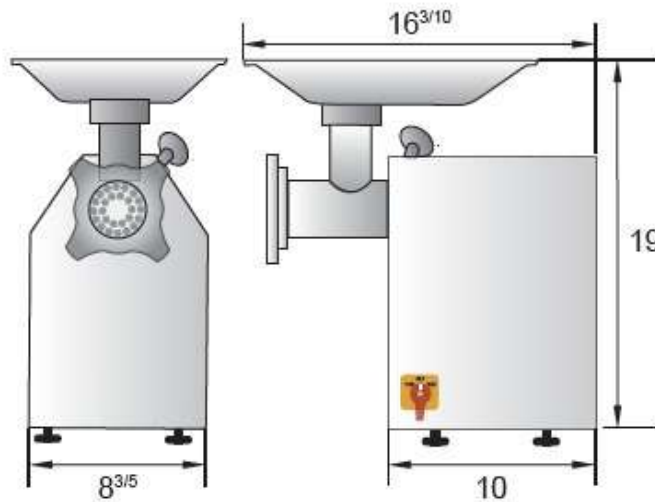

Food tray support



Meat grinder attachments



Meat pusher



Sausage Stuffer





Toll free +1 (833) 978 8833  
 sales@mckequipment.ca  
 Visit [mckonline.ca](http://mckonline.ca) for more details

Quality Kitchen  
 Equipment & Supplies



# Vegetable Chopper & Cheese Slicer

MCK-TT-F30

## FEATURES

- Equipped with a 0.75 HP motor for efficient food processing.
- Heavy-duty design built to withstand constant use in busy kitchens.
- Capable of slicing, dicing, shredding, and more.
- Designed to handle large volumes of food with ease.
- Simple controls for quick and intuitive use.
- Includes safety interlocks and guards for secure operation.
- Removable parts for convenient cleaning and maintenance.
- Ensures stability during operation, preventing slips and accidents.
- Ideal for restaurants, catering services, and commercial kitchens.



MCK-TT-F30



Included: P2 Slicing Disc 2mm, P3 Slicing Disc 3mm, H3 Shredding Disc 3mm, H4 Shredding Disc 4mm, H7 Shredding Disc 7mm





Toll free +1 (833) 978 8833  
 sales@mckequipment.ca  
 Visit [mckonline.ca](http://mckonline.ca) for more details



### SPECIFICATIONS

Model	Type	Power Type	Voltage	Watts	Horsepower (HP)	Disc Speed	Phase	Hertz	Mouth Opening (Inch)	Exterior Dimensions (Inch)	Net Weight (lbs)	Gross Weight (lbs)
MCK-TT-F30	Food Processor	Electric	110V	0.56 kW	0.75	270 RPM	1 Phase	60 Hz	5.11 x 2.16	19 x 9 x 19.7	50.6	55

### PLAN VIEW

MCK-TT-F30

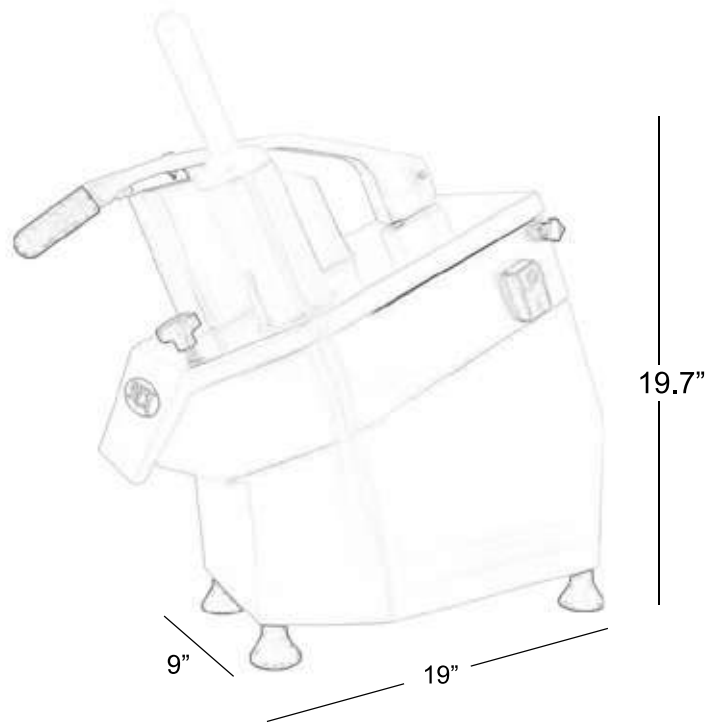



Toll free +1 (833) 978 8833  
 sales@mckequipment.ca  
 Visit [mckonline.ca](http://mckonline.ca) for more details



# Bowl Cutter Processor

MCK-GD-HR-9 | MCK-GD-HR-12

## FEATURES

- Large Capacity bowl for processing large quantities
- Equipped with a robust motor for efficient processing
- Suitable for chopping, mixing, and emulsifying a variety of ingredients
- Made with high-quality materials for long-lasting use
- Includes safety mechanisms to prevent accidents during operation
- Components are easy to disassemble and clean
- User-Friendly Controls: Simple interface for easy operation
- Space-saving design ideal for commercial kitchens
- Comes with different blades for various processing tasks
- Designed with a stable base to prevent movement during use



MCK-GD-HR-9



MCK-GD-HR-12





Toll free +1 (833) 978 8833  
 sales@mckequipment.ca  
 Visit [mckonline.ca](http://mckonline.ca) for more details



### SPECIFICATIONS

Model	Power (W)	Capacity	Electrical	RPM	Dimensions (DWH Inch)	Gross Dimensions (DWH Inch)	Net Weight (lbs)	Gross Weight (lbs)
MCK-GD-HR-9	1 HP / 0.75 kW	4.22 - 6.35 QT 4 - 6 L	110V/60Hz/1	1100 - 2800	15 x 11 x 15	22.50 x 14.25 x 17.50	42	45
MCK-GD-HR-12		6.35 - 9.50 QT 6 - 9 L		1100 - 2800	18.50 x 11.41 x 17	22.50 x 15.25 x 18.25	44	47

### PLAN VIEW

MCK-GD-HR-9

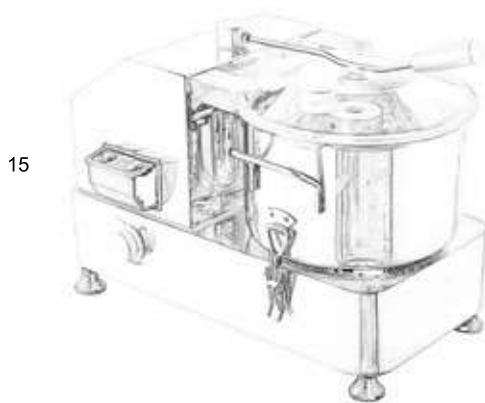

MCK-GD-HR-12

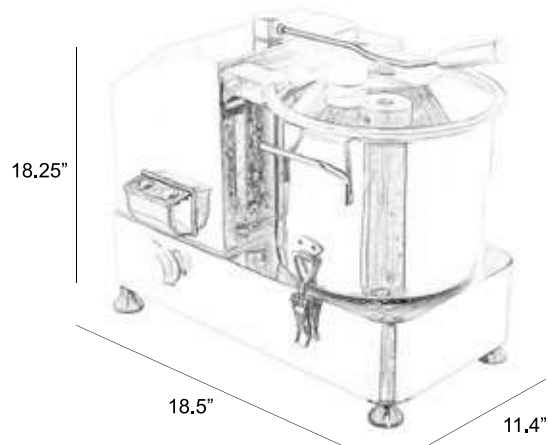

Speed Knob



Safety Lock



Stainless Steel



Stainless Steel Knife





Toll free +1 (833) 978 8833  
 sales@mckequipment.ca  
 Visit [mckonline.ca](http://mckonline.ca) for more details

Quality Kitchen  
 Equipment & Supplies



# Bone Saw

HLS1650 | HLS1900A | HLS2400

## Description:

- Commercial bone saw machine, with stainless steel body, rust resistant and easy to clean
- 304 stainless steel belt pulley, wear resistant and does not deform
- High-power motor, no lagging, achieving stable operation without shaking



**HLS1650**





Toll free +1 (833) 978 8833  
sales@mckequipment.ca  
Visit [mckonline.ca](http://mckonline.ca) for more details

Quality Kitchen  
Equipment & Supplies



### SPECIFICATIONS

<b>Model Number</b>	<b>Size (inches)</b>	<b>Net Weight (lbs)</b>	<b>Gross Weight (lbs)</b>
<b>HLS1650</b>	20.87 x 18.31 x 34.33	81.57	119.67
<b>HLS1900A</b>	22.26 x 20.91 x 39.82	115.96	127.87
<b>HLS2400</b>	31.65 x 29.29 x 68.19	321.87	409.08



Toll free +1 (833) 978 8833  
sales@mckequipment.ca  
Visit [mckonline.ca](http://mckonline.ca) for more details

Quality Kitchen  
Equipment & Supplies



# Immersion Blender

**MCK-IB500LV**

**MCK-IB750LV**

## Description:

- Equipped with a safety button
- Elegant design made from 304 stainless steel
- High performance blade and shaft that is conveniently removable for easy cleaning





Toll free +1 (833) 978 8833  
 sales@mckequipment.ca  
 Visit [mckonline.ca](http://mckonline.ca) for more details



**SPECIFICATIONS**

Model Number	Size (inches)	Net Weight (lbs)	Gross Weight (lbs)
<b>MCK-IB500LV</b>	Blender Length: 14.69 Total Length of Tube: 16.14 Steel part Length of whisk: 10.12 Total Length of whisk: 15.30	Blender Weight: 5.07 Tube Weight: 2.78 Whisk Weight: 1.98	10.01
<b>MCK-IB750LV</b>	Blender Length: 15.59 Total Length of Tube: 22.05 Steel part Length of whisk: 10.12 Total Length of whisk: 15.30	Blender Weight: 6.17 Tube Weight: 3.79 Whisk Weight: 1.98	13.80





Toll free +1 (833) 978 8833  
sales@mckequipment.ca  
Visit [mckonline.ca](http://mckonline.ca) for more details



# **FOOD PRESENTATION & DISPLAY**

Display Warmer

Pizza Warmer

Food Warmer



Toll free +1 (833) 978 8833  
 sales@mckequipment.ca  
 Visit [mckonline.ca](http://mckonline.ca) for more details



# Display Warmers

MCK-FTR-76L | MCK-FTR-96L | MCK-FTR-136L

## FEATURES

- Brilliant Internal LED illumination on top
- Adjustable temperature controller
- Adjustable chrome plated shelves
- Opens front and back. (MCK-1) Front hinged door
- Designed with adjustable trays and glass on all sides
- Equipped with a thermostat monitor for consistent temperatures
- Water tray included to add humidity to the cabinet



MCK-FTR-76L



MCK-FTR-96L



MCK-FTR-136L





Toll free +1 (833) 978 8833  
 sales@mckequipment.ca  
 Visit [mckonline.ca](http://mckonline.ca) for more details



## SPECIFICATIONS

Model	Temp. Range	Storage Volume	Power (W)	Lamp Power	Shelves	Shelf Load Capacity (lbs)	Electrical	Dimensions (DWH Inch)	Gross Dimensions (DWH Inch)	Net Weight (lbs)	Gross Weight (lbs)
MCK-FTR-76L	30°C - 90°C 86 - 194°F	76 L	800	1.44 x 3 W	3	22	110 V 60 Hz 1 Ph	19.54" x 13.17" x 26"	21.69" x 16" x 27.36"	46.7	50.7
MCK-FTR-96L		96 L	1000			22		25.75" x 19.8" x 26.2"	29.1" x 21.7" x 27.4"	96	100
MCK-FTR-136L		136 L	1100			33		35" x 18.8" x 26.2"	38.3" x 21.7" x 27.4"	136	140
MCK-FTR-186L		186 L	1800			22		19.38" x 47.4" x 26"	21.69" x 50.3" x 27.36"	117.9	123.45

## PLAN VIEW

MCK-FTR-76L

MCK-FTR-96L

TECHNICAL DRAWINGS WITH DETAILED DIMENSIONS:

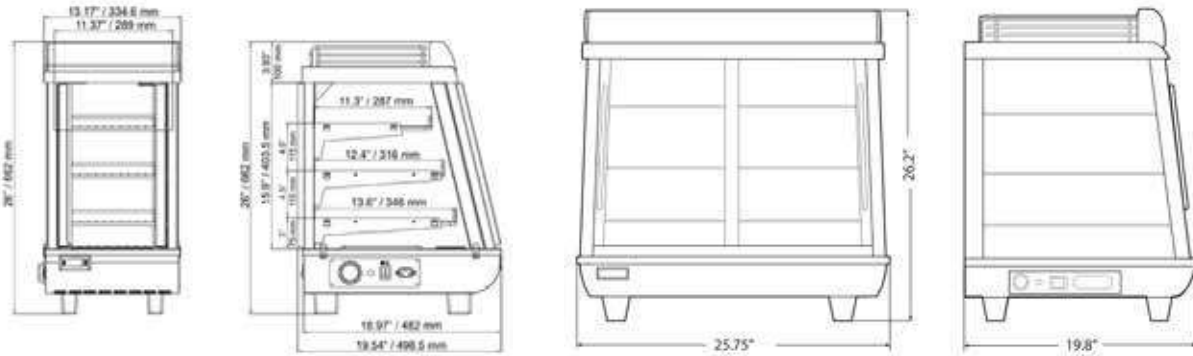

MCK-FTR-136L

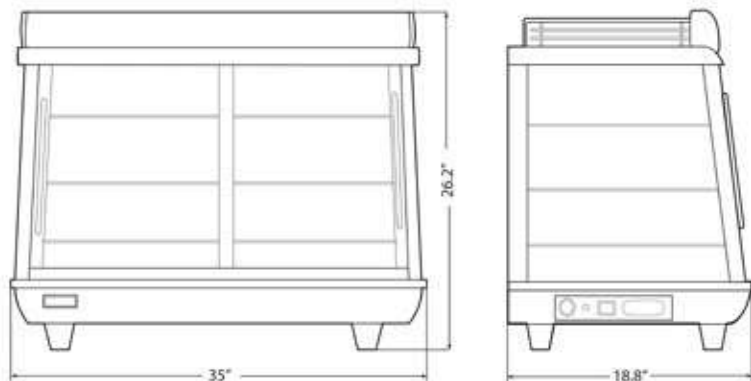



Toll free +1 (833) 978 8833  
 sales@mckequipment.ca  
 Visit [mckonline.ca](http://mckonline.ca) for more details

Quality Kitchen  
 Equipment & Supplies



# Display Warmers

MCK-FTR-186L



MCK-FTR-186L

## FEATURES

- Brilliant Internal LED illumination on top
- Adjustable temperature controller
- Adjustable chrome plated shelves
- Opens front and back.
- (MCK-1) Front hinged door
- Designed with adjustable trays and glass on all sides
- Equipped with a thermostat monitor for consistent temperatures
- Water tray included to add humidity to the cabinet





## SPECIFICATIONS

Model	Temp. Range	Storage Volume	Power (W)	Lamp Power	Shelves	Shelf Load Capacity (lbs)	Electrical	Dimensions (DWH Inch)	Gross Dimensions (DWH Inch)	Net Weight (lbs)	Gross Weight (lbs)
MCK-FTR-76L	30°C - 90°C 86 - 194°F	76 L	800	1,44 x 3 W	3	22	110 V 60 Hz 1 Ph	19.54" x 13.17" x 26"	21.69" x 16" x 27.36"	46.7	50.7
MCK-FTR-96L		96 L	1000			22		25.75" x 19.8" x 26.2"	29.1" x 21.7" x 27.4"	96	100
MCK-FTR-136L		136 L	1100			33		35" x 18.8" x 26.2"	38.3" x 21.7" x 27.4"	136	140
MCK-FTR-186L		186 L	1800			22		19.38" x 47.4" x 26"	21.69" x 50.3" x 27.36"	117.9	123.45

## PLAN VIEW

MCK-FTR-186L

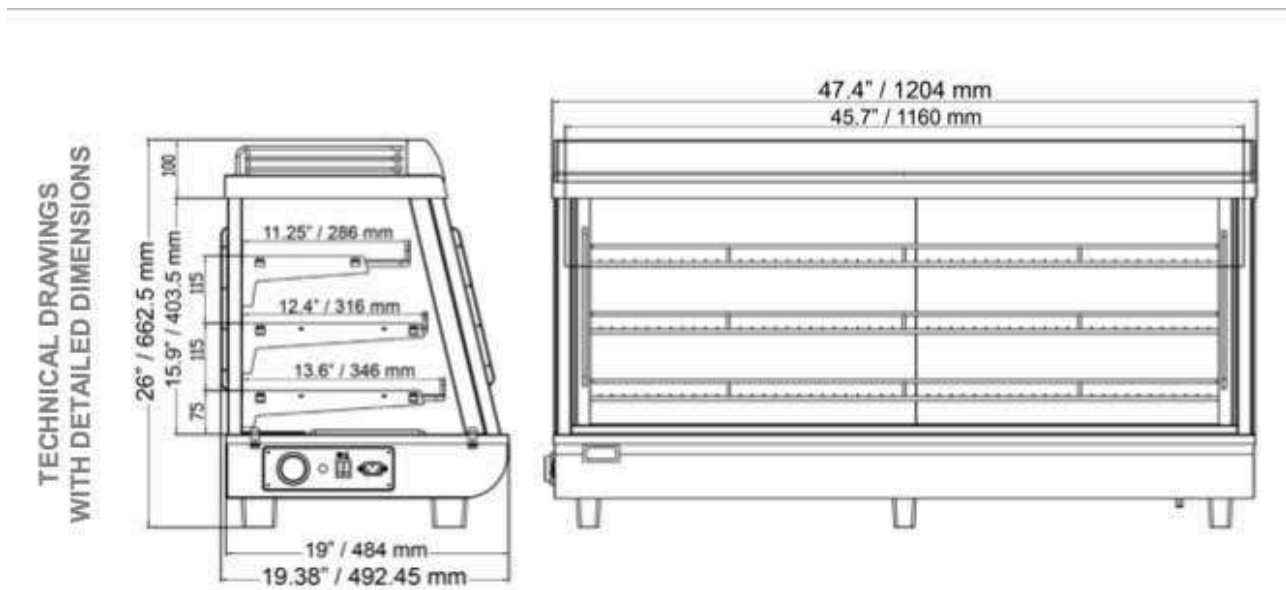

Water Tray



Sliding Doors (Front)



Sliding Doors (Back)



Temperature Control





Toll free +1 (833) 978 8833  
 sales@mckequipment.ca  
 Visit [mckonline.ca](http://mckonline.ca) for more details

Quality Kitchen  
 Equipment & Supplies



# Display Warmer

MCK-FTR-25L | MCK-FTR-45L | MCK-FTR-138L |  
 MCK-FTR-188L

## FEATURES

- Four sided glass body with black framing & base.
- Interior LED lighting on all four sides.
- Locks on front and rear side to control customer access.
- Adjustable shelves.
- Front and back sliding doors for 138L and 186L.
- Adjustable temperature controller.
- Maintains temperatures between 86°F – 194°F.



MCK-FTR-25L



MCK-FTR-45L



MCK-FTR-188L



MCK-FTR-138L





Toll free +1 (833) 978 8833  
 sales@mckequipment.ca  
 Visit [mckonline.ca](http://mckonline.ca) for more details

Quality Kitchen  
 Equipment & Supplies



## SPECIFICATIONS

Model	Capacity (L)	Shelves	Rated Current (A)	Voltage (V/Hz/Ph)	HP (W)	Refrigerant	Exterior Dimensions (W x L x H inches)	Net Weight (lbs)	Gross Weight (lbs)																			
MCK-FTR-25L	25	1	7	110/60/1	800	R290	22.1 x 15 x 12	161	169																			
MCK-FTR-45L	45	7	110/60/1	800	R290	22.1 x 15 x 15	167	176	MCK-FTR-138L	136	3	9.5	110/60/1	1100	R290	36 x 19.1 x 26.1	196	206	MCK-FT-188L	186	3	13	110/60/1	1500	R290	47.8x 19.1 x 26.1	201	211
MCK-FTR-138L	136	3	9.5	110/60/1	1100	R290	36 x 19.1 x 26.1	196	206																			
MCK-FT-188L	186	3	13	110/60/1	1500	R290	47.8x 19.1 x 26.1	201	211																			

## PLAN VIEW

MCK-FTR-25L

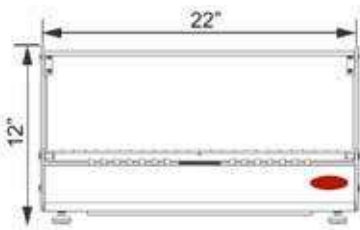

MCK-FTR-45L

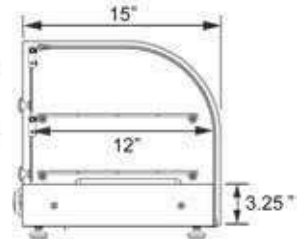
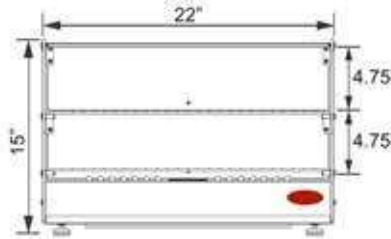
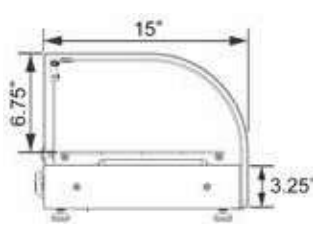

MCK-FTR-138L

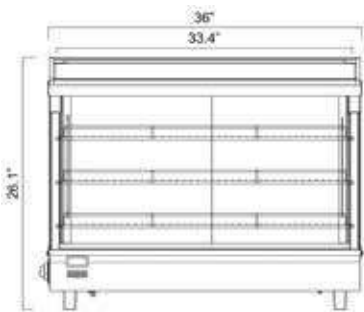

MCK-FTR-188L

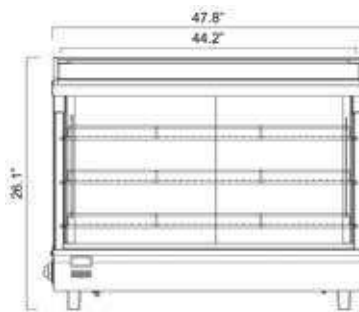

Side Dimensions



Shelves



Control



Door Handle



Adjustable



Caster





Toll free +1 (833) 978 8833  
 sales@mckequipment.ca  
 Visit [mckonline.ca](http://mckonline.ca) for more details

Quality Kitchen  
 Equipment & Supplies



# Pizza Display Warmer

MCK-FTR-97L | MCK-RTR-97L-2

## FEATURES

- Specially designed for displaying food while keeping consistent temperature
- Adjustable temperature controller
- Temperature display
- Adjustable chrome plated shelves
- Back doors
- Front top light box with decals
- Led Lighting
- QPS Approved



MCK-FTR-97L



FTR-107L | FTR-137L



MCK-FTR-97L-2





## SPECIFICATIONS

Model	Temperature Range	Capacity	Power (W)	Shelves	Shelf Type	Electrical	Dimensions (DWH Inch)	Package Dimensions (DWH Inch)	Net Weight (lbs)	Gross Weight (lbs)
<b>FTR-97L</b>	30°C - 90°C 86°F - 194°F	97 L	800	3	Static	110V	18.1" x 17.6" x 30.9"	21" x 21.1" x 32.8"	48.5	50.5
<b>FTR-97L-2</b>	30°C - 90°C 86°F - 194°F	97 L	800	4	Rotating	110V	18.1" x 17.6" x 30.9"	21" x 21.1" x 32.8"	48.5	50.5
<b>FTR-107L</b>	30°C - 90°C 86°F - 194°F	107 L	800	3	Static	110V	25.39 x 16.54 x 25.87	27.95 x 18.31 x 28.50	52	60
<b>FTR-137L</b>	30°C - 90°C 86°F - 194°F	137 L	800	3	Static	110V	25.39 x 16.54 x 30.91	27.95 x 18.31 x 33.62	60	68

## PLAN VIEW

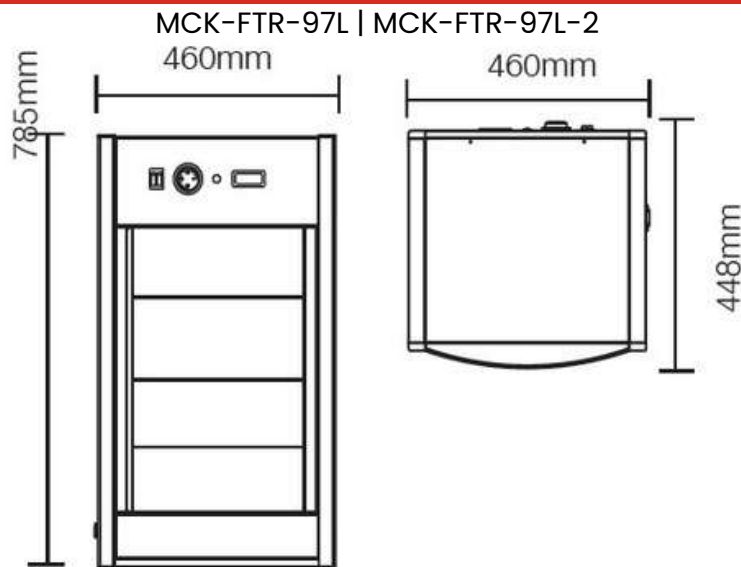

Temperature Controller



Temperature Display



Back Doors





Toll free +1 (833) 978 8833  
 sales@mckequipment.ca  
 Visit [mckonline.ca](http://mckonline.ca) for more details

Quality Kitchen  
 Equipment & Supplies



# Food Warmer

**ZCK165BT**



## Description:

- 1 full size pan or 2 half size pans food warmer
- Stainless steel
- Adjustable thermostat

### SPECIFICATIONS

Model Number	Size (inches)	Net Weight (lbs)	Gross Weight (lbs)	Capacity
ZCK165BT	22.72 x 13.39 x 9.45	15.54	18.63	1 full size pan or 2 half-size pans





Toll free +1 (833) 978 8833  
sales@mckequipment.ca  
Visit [mckonline.ca](http://mckonline.ca) for more details



# **DISHWASHER EQUIPMENT**

Undercounter  
Hood Type



Toll free +1 (833) 978 8833  
 sales@mckequipment.ca  
 Visit [mckonline.ca](http://mckonline.ca) for more details

Quality Kitchen  
 Equipment & Supplies



# Undercounter Dishwasher

MCK-GD-H50-S1

## FEATURES

- Handles up to 30 racks per hour
- Uses only 0.66 gallons per cycle for dish/glass washing
- High-temperature operation: 140°F wash / 180°F rinse
- Three cycle options: 120, 150, and 180 seconds
- Double-skin body and door to reduce energy loss and minimize steam escape
- Pumped rinse system for consistent cleaning results
- Compact design: 32½" height and 158 lbs, ideal for smaller kitchens
- Comes with chemical dispensers, fill hose, and drain hose for easy installation



MCK-GD-H50-S1





## SPECIFICATIONS

Model	Phase	Voltage	Herz	Water Inlet	Water Consumption	Max. Capacity	Temp. Range	Cycles (Seconds)	Clearance	Dimensions (DWH Inch)	Net Weight (lbs)
MCK-GD-H50-S1	3 Phase	208V-240V	60 Herz	3/4"	0.66 Gallons / R	30 Racks / H	Wash: 140°F Resine: 180°F	120/150/180	12"	25" x 24.61" x 35 1/2"	158

Rotating stainless steel wash & rinse arm with WIDE ANGLE FAN nozzle to maximise wash & rinse performance. Double skin body and door - avoiding loss of energy / steam.

## PLAN VIEW

MCK-GD-H50-S1

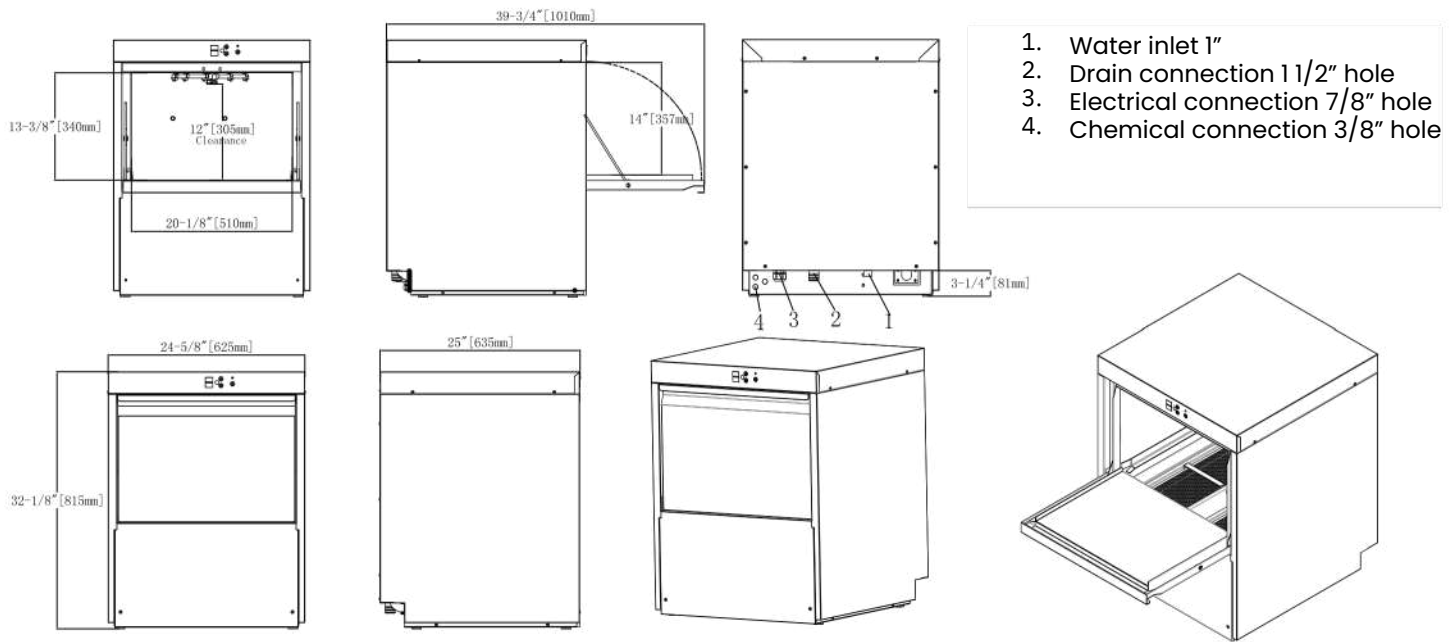

Temperature Controller



Washing Rack



Stainless Steel





Toll free +1 (833) 978 8833  
 sales@mckequipment.ca  
 Visit [mckonline.ca](http://mckonline.ca) for more details

Quality Kitchen  
 Equipment & Supplies



# Hood Type Dishwasher

MCK-GD-H60-S1

## FEATURES

- Handles up to 50 racks per hour
- Uses only 0.74 gallons of water per cycle for dish and glass washing, making it both cost-effective and environmentally friendly
- The deep-drawn tank is seamless with no welds, ensuring optimum hygiene and preventing any leaks or corrosion
- Comes with electronic controls offering 3 cycles (70, 100, and 130 seconds) for flexibility in washing times
- Wash temperature at 148°F and rinse temperature at 180°F for thorough sanitization
- Equipped with a rotating stainless steel wash & rinse arm with a WIDE ANGLE FAN nozzle for maximum cleaning performance
- Includes a 1 HP wash pump, inlet strainer, and a pumped resin system to ensure reliable and consistent operation
- Includes chemical dispensers, fill hose, and drain hose for quick and easy setup



MCK-GD-H60-S1





## SPECIFICATIONS

Model	Phase	Voltage	Frequency	Water Inlet	Water Consumption	Capacity	Temp. Range	Cycles (Seconds)	Clearance	Dimensions (DWH Inch)	Net Weight (lbs)
MCK-GD-H60-S1	3 Phase	208V-240V	60 Hertz	3/4"	0.74 Gallons / R	50 Racks / H	Wash: 140°F Rinse: 180°F	120/150/180	16"	32.68" x 28.54" x 55 1/2"	225

Rotating stainless steel wash & rinse arm with WIDE ANGLE FAN nozzle to maximise wash & rinse performance. Optimum hygienic - deep drawn tank with covered corners (no welds).

## PLAN VIEW

MCK-GD-H60-S1

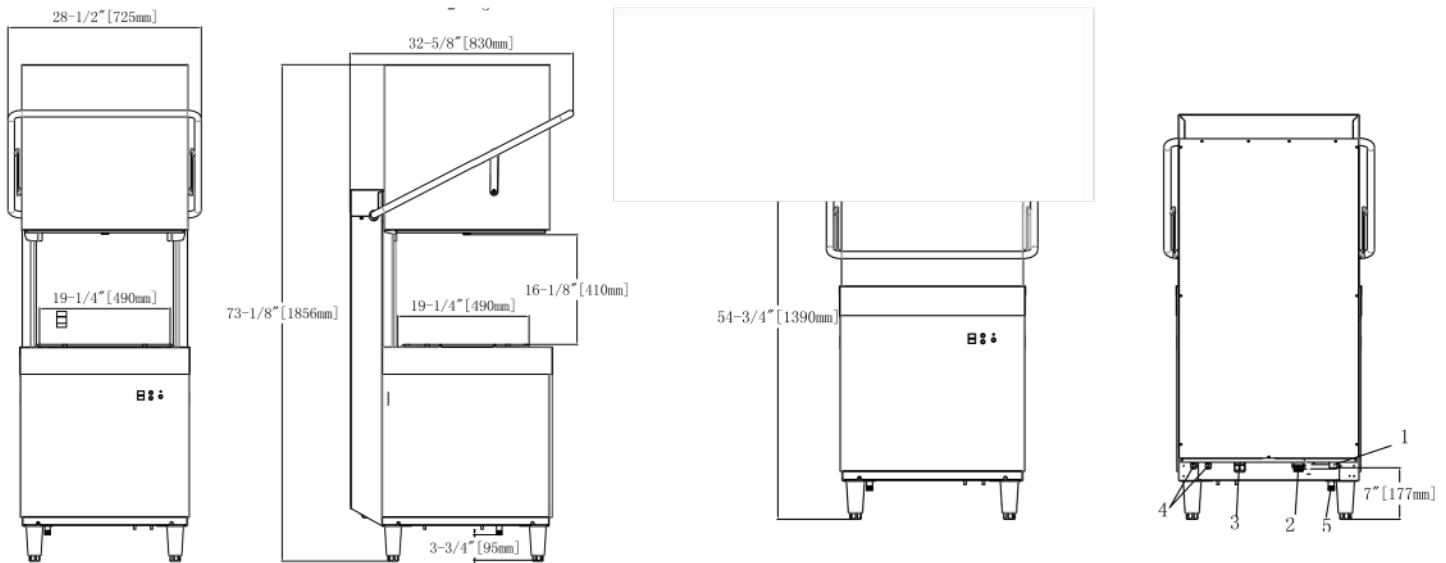

1. Water inlet 1"
2. Drain connection 1 1/2" hole
3. Electrical connection 7/8" hole
4. Chemical connection 3/8" hole
5. Drain connection 3/4" hole

Cycle  
Controller



Washing Rack



Stainless Steel





Toll free +1 (833) 978 8833  
sales@mckequipment.ca  
Visit [mckonline.ca](http://mckonline.ca) for more details



# **SINKS, TABLES AND EQUIPMENT STANDS**

S/S Tables

S/S Shelves & Pot Hook Racks

S/S Sinks

S/S Table with Sinks

Overshelves

Sink ACCESSORIES



Toll free +1 (833) 978 8833  
 sales@mckequipment.ca  
 Visit [mckonline.ca](http://mckonline.ca) for more details

Quality Kitchen  
 Equipment & Supplies



# Work Tables (24" Depth Series)

SS-T2424CWP

## FEATURES

- 18 gauge, 430 stainless steel table including the undershelf and legs
- Galvanized Under Shelf and Galvanized Legs
- Entire top mechanically polished to a satin finish
- Top is sound deadened
- All edges are turned down as a safety feature
- Stainless steel tubular legs and undershelf are standard features on all models
- Under shelf can be adjusted to desired height
- Adjustable bullet feet
- Easy to assemble



SS-T2424CWP

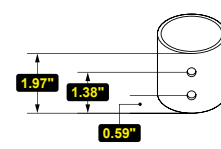
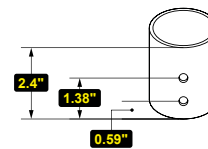
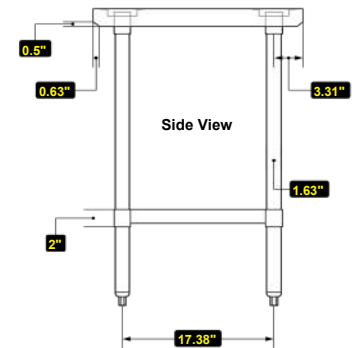
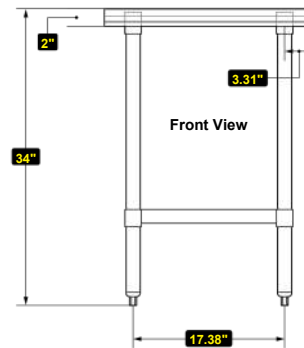



## SPECIFICATIONS

Model	Legs	Dimensions (WDH Inch)	Weight (lbs)
SS-T2424CWP	4	24" W x 24" D x 34" H	35
SS-T2430CWP	4	30" W x 24" D x 34" H	42
SS-T2436CWP	4	36" W x 24" D x 34" H	46
SS-T2448CWP	4	48" W x 24" D x 34" H	56
SS-T2460CWP	4	60" W x 24" D x 34" H	66
SS-T2472CWP	4	72" W x 24" D x 34" H	76
SS-T2484CWP	4	84" W x 24" D x 34" H	86
SS-T2496CWP	4	96" W x 24" D x 34" H	96

## PLAN VIEW





Toll free +1 (833) 978 8833  
 sales@mckequipment.ca  
 Visit [mckonline.ca](http://mckonline.ca) for more details

Quality Kitchen  
 Equipment & Supplies



# Work Tables with Backsplash (24" Depth Series)

SS-T2424CWP-B

## FEATURES

- 18 gauge, 430 stainless steel table including the undershelf and legs
- Galvanized Under Shelf and Galvanized Legs
- 4" Backsplash
- Entire top mechanically polished to a satin finish
- Top is sound deadened
- All edges are turned down as a safety feature
- Stainless steel tubular legs and undershelf are standard features on all models
- Under shelf can be adjusted to desired height
- Adjustable bullet feet
- Easy to assemble



SS-T2424CWP-B

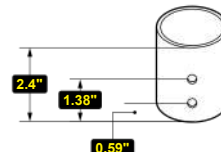
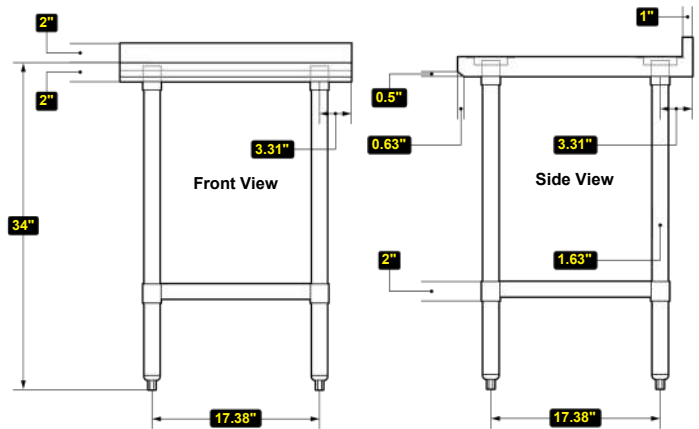

Channel Socket

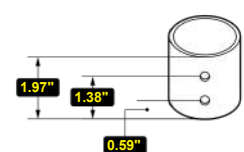

Undershelf Socket





## SPECIFICATIONS

Model	Legs	Dimensions (WDH Inch)	Weight (lbs)
SS-T2424CWP-B	4	24" W x 24" D x 34" H	36
SS-T2430CWP-B	4	30" W x 24" D x 34" H	42
SS-T2436CWP-B	4	36" W x 24" D x 34" H	46
SS-T2448CWP-B	4	48" W x 24" D x 34" H	56
SS-T2460CWP-B	4	60" W x 24" D x 34" H	66
SS-T2472CWP-B	4	72" W x 24" D x 34" H	76
SS-T2484CWP-B	6	84" W x 24" D x 34" H	86
SS-T2496CWP-B	6	96" W x 24" D x 34" H	96

## PLAN VIEW

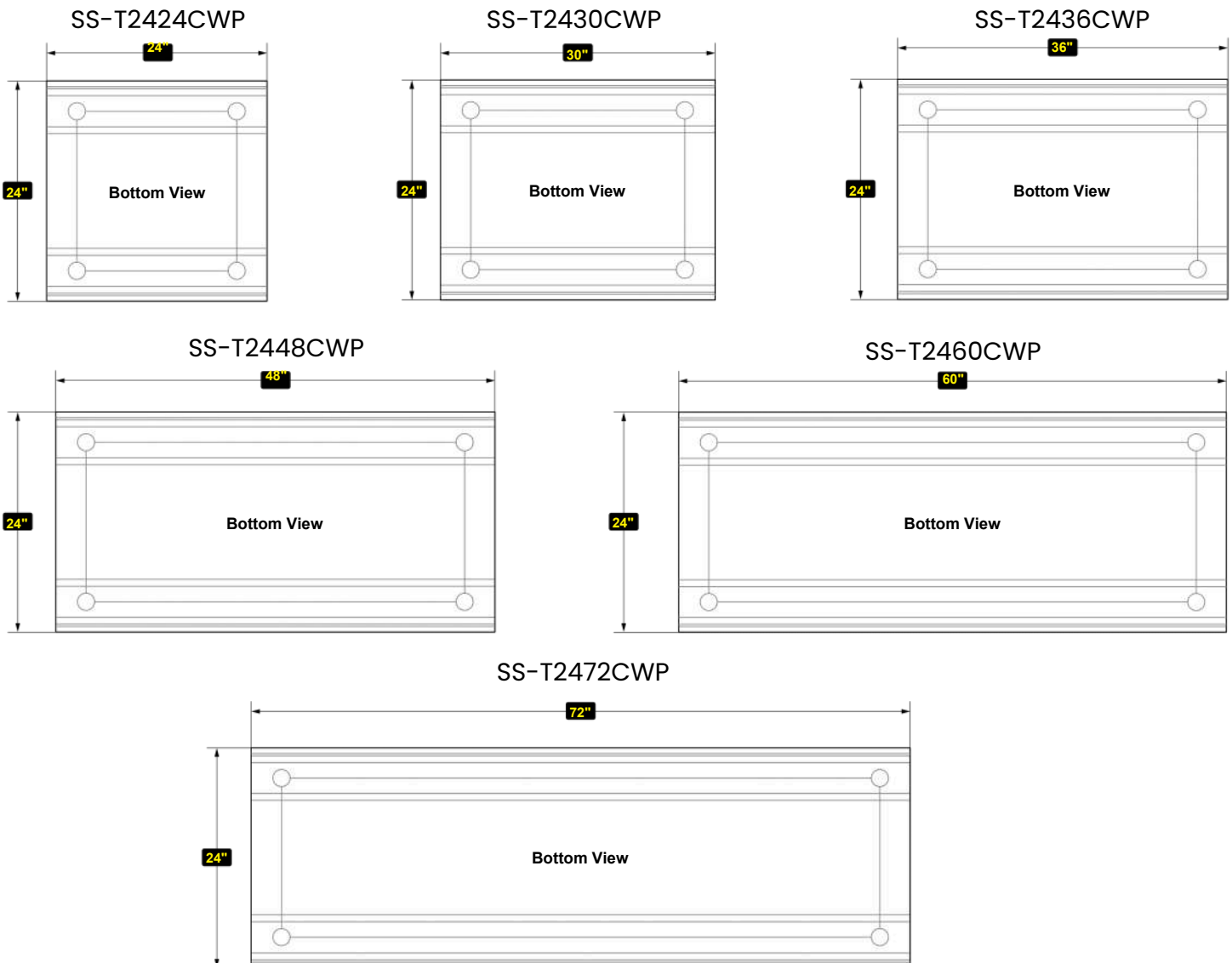



Toll free +1 (833) 978 8833  
 sales@mckequipment.ca  
 Visit [mckonline.ca](http://mckonline.ca) for more details

Quality Kitchen  
 Equipment & Supplies



# Work Tables (30" Depth Series)

## FEATURES

- 18 gauge, 430 stainless steel table including the undershelf and legs
- Galvanized Under Shelf and Galvanized Legs
- Entire top mechanically polished to a satin finish
- Top is sound deadened
- All edges are turned down as a safety feature
- Stainless steel tubular legs and undershelf are standard features on all models
- Under shelf can be adjusted to desired height
- Adjustable bullet feet
- Easy to assemble



SS-T3024CWP

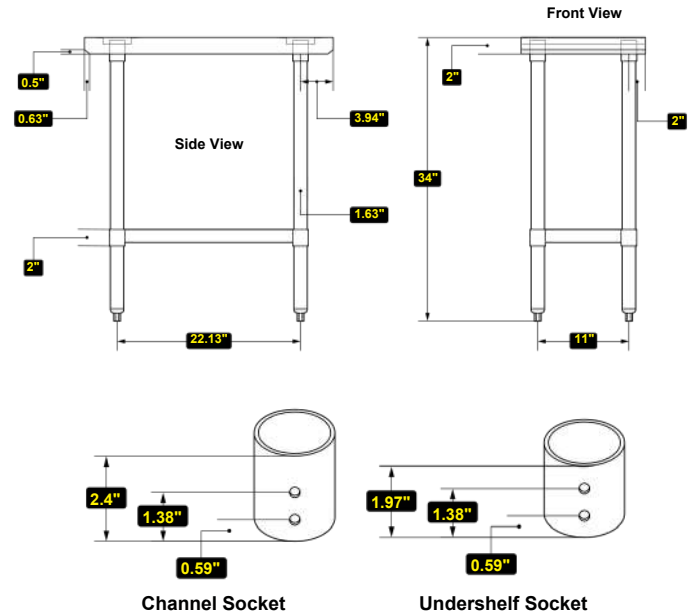



## SPECIFICATIONS

Model	Legs	Dimensions (WDH Inch)	Weight (lbs)
SS-T3015CWP	4	15" W x 30" D x 34" H	32
SS-T3018CWP	4	18" W x 30" D x 34" H	37
SS-T3024CWP	4	24" W x 30" D x 34" H	43
SS-T3030CWP	4	30" W x 30" D x 34" H	49
SS-T3036CWP	4	36" W x 30" D x 34" H	52
SS-T3048CWP	4	48" W x 30" D x 34" H	62
SS-T3060CWP	4	60" W x 30" D x 34" H	72
SS-T3072CWP	4	72" W x 30" D x 34" H	82
SS-T3084CWP	6	84" W x 30" D x 34" H	96
SS-T3096CWP	6	96" W x 30" D x 34" H	111

## PLAN VIEW

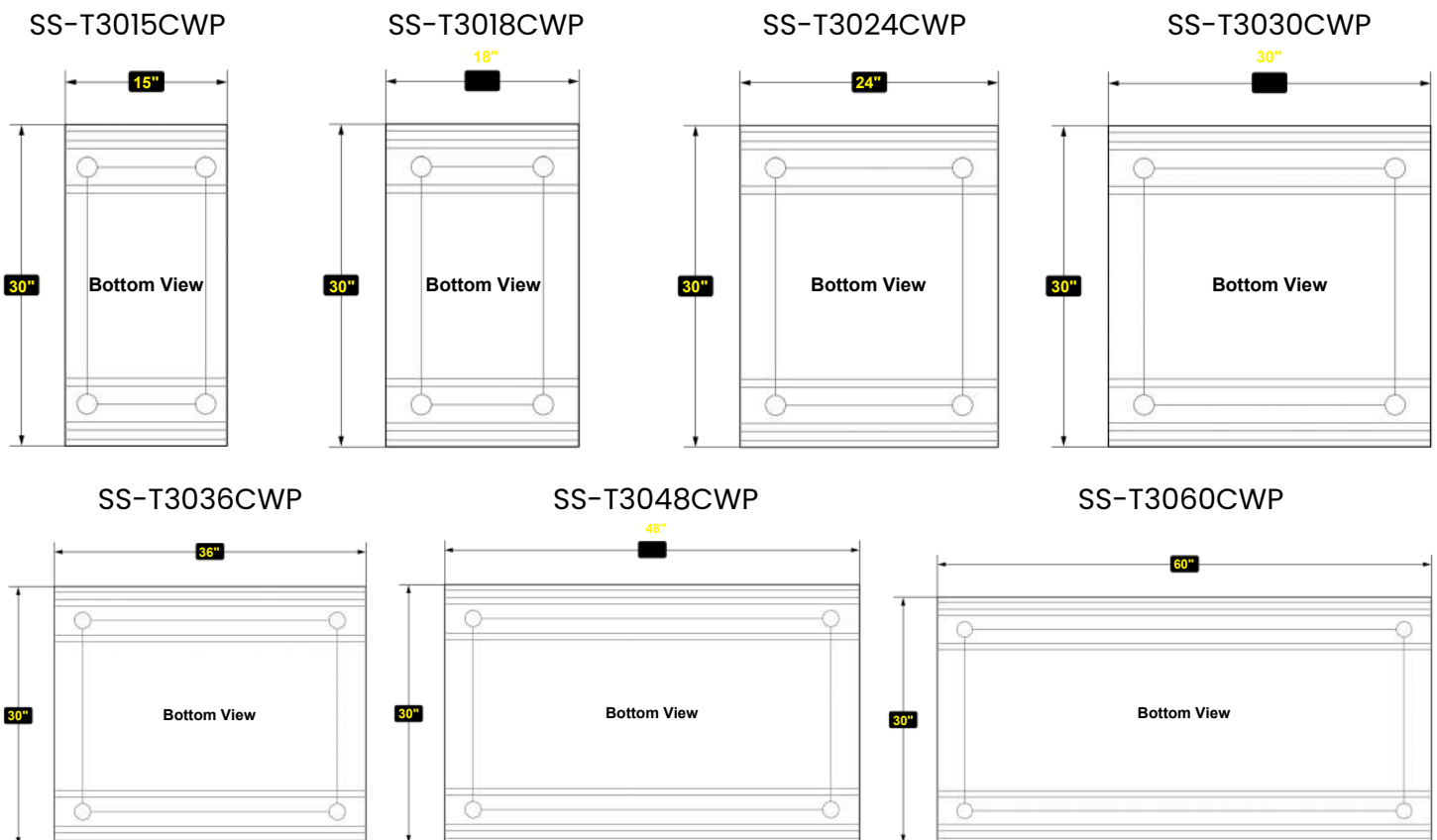



Toll free +1 (833) 978 8833  
 sales@mckequipment.ca  
 Visit [mckonline.ca](http://mckonline.ca) for more details

Quality Kitchen  
 Equipment & Supplies



# Work Tables with Backsplash (30" Depth Series)

## FEATURES

- 18 gauge, 430 stainless steel table including the undershelf and legs
- Galvanized Under Shelf and Galvanized Legs
- 4" Backsplash
- Entire top mechanically polished to a satin finish
- Top is sound deadened
- All edges are turned down as a safety feature
- Stainless steel tubular legs and undershelf are standard features on all models
- Under shelf can be adjusted to desired height
- Adjustable bullet feet
- Easy to assemble



SS-T3024CWP-B

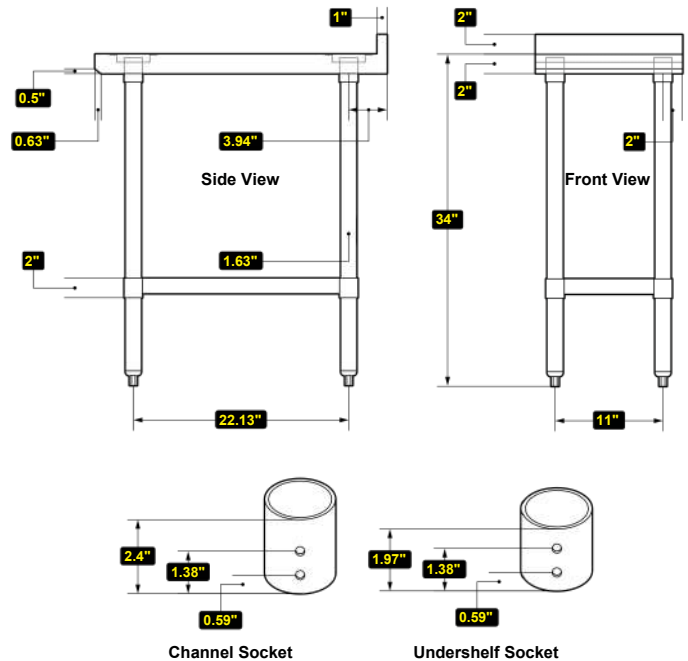



## SPECIFICATIONS

Model	Legs	Dimensions (WDH Inch)	Weight (lbs)
SS-T3015CWP-B	4	15" W x 30" D x 34" H	35
SS-T3018CWP-B	4	18" W x 30" D x 34" H	40
SS-T3024CWP-B	4	24" W x 30" D x 34" H	43
SS-T3030CWP-B	4	30" W x 30" D x 34" H	49
SS-T3036CWP-B	4	36" W x 30" D x 34" H	52
SS-T3048CWP-B	4	48" W x 30" D x 34" H	62
SS-T3060CWP-B	4	60" W x 30" D x 34" H	72
SS-T3072CWP-B	4	72" W x 30" D x 34" H	82
SS-T3084CWP-B	6	84" W x 30" D x 34" H	98
SS-T3096CWP-B	6	96" W x 30" D x 34" H	118

## PLAN VIEW

SS-T3015CWP-B

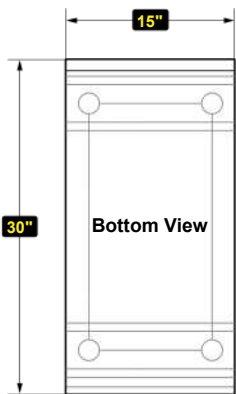

SS-T3018CWP-B

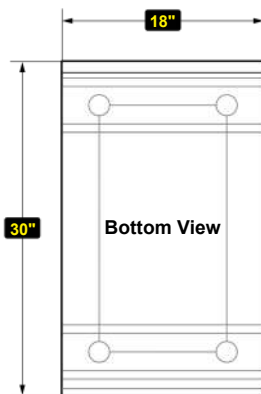

SS-T3024CWP-B

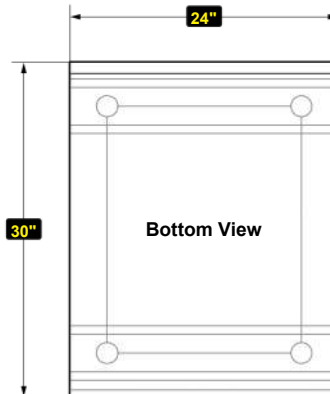

SS-T3030CWP-B

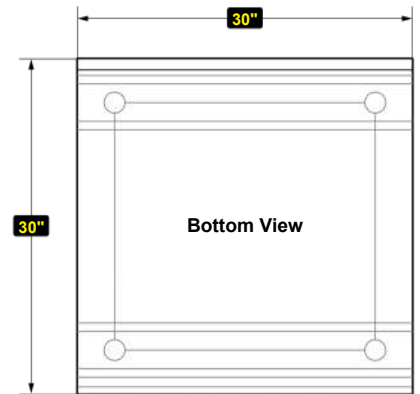

SS-T3036CWP-B

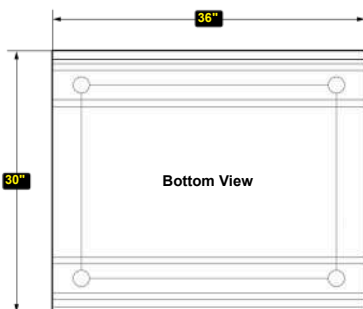

SS-T3048CWP-B

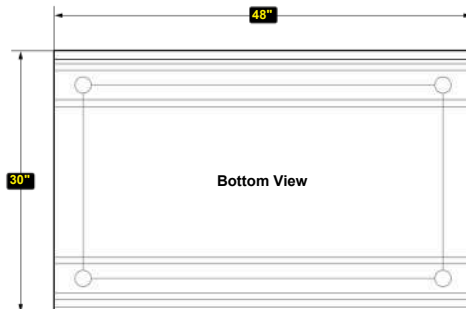

SS-T3060CWP-B

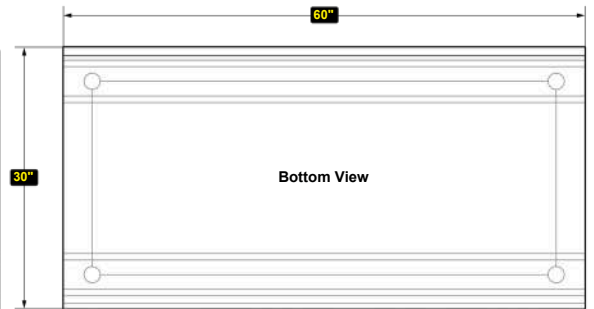



Toll free +1 (833) 978 8833  
 sales@mckequipment.ca  
 Visit [mckonline.ca](http://mckonline.ca) for more details

Quality Kitchen  
 Equipment & Supplies



# Storage Shelf

## FEATURES

- Maximizes the available space
- Made of 18-gauge 430 stainless steel
- Convenient and simple design
- Stainless steel leg and socket



## SPECIFICATIONS

Model	Capacity (lbs)	Dimensions (WDH Inch)
SS-KS-PJY-001	380	47" x 20" x 61"
SS-KS-PJY-002	380	47" x 23.6" x 61"
SS-KS-PJY-003	400	59" x 20" x 61"
SS-KS-PJY-004	400	59" x 23.6" x 61"
SS-KS-PJY-005	420	70.8" x 20" x 61"
SS-KS-PJY-006	420	70.8" x 23.6" x 61"

## PLAN VIEW

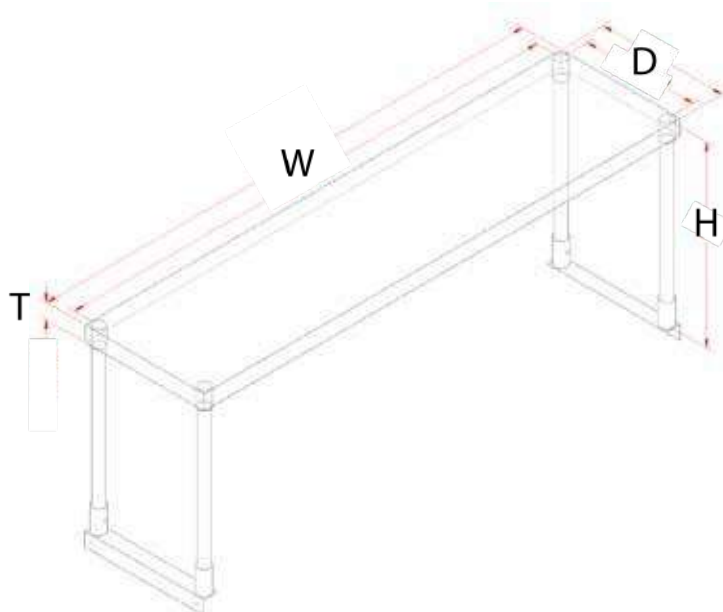



Toll free +1 (833) 978 8833  
 sales@mckequipment.ca  
 Visit [mckonline.ca](http://mckonline.ca) for more details

# Double Over Shelf

## FEATURES

- Doubles the available space
- Made of 18-gauge 430 stainless steel
- Convenient and simple design
- Double tier; stainless steel leg and socket. Bottom shelf can be adjusted



## SPECIFICATIONS

Model	Capacity (lbs)	Dimensions (WDH Inch)
SS-KSOS-3E	187	12" x 36" x 32"
SS-KSOS-4E	187	12" x 48" x 32"
SS-KSOS-5RE	209	12" x 60" x 32"
SS-KSOS-6RE	209	12" x 72" x 32"
SS-KSOS-3	187	14" x 36" x 32"
SS-KS-1460	209	14" x 60" x 32"
SS-KS-1472	209	14" x 72" x 32"

## PLAN VIEW

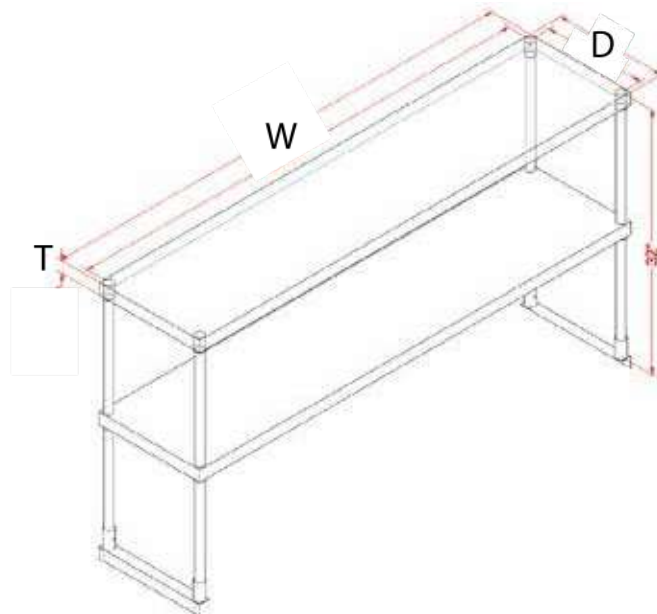



# Equipment Stands

## FEATURES

- 16 Gauge, 304 Series SS Top
- 18 Gauge, 430 Series SS Undershef and Legs
- Constructed with a 1" Backsplash



## SPECIFICATIONS

Model	Dimensions (WDH Inch)	Weight (lbs)
SS-TSE-3012	12" W x 30" D x 2" H	14
SS-TSE-3018	18" W x 30" D x 2" H	21
SS-TSE-3024	24" W x 30" D x 2" H	24
SS-TSE-3036	36" W x 30" D x 2" H	42
SS-TSE-3048	48" W x 30" D x 2" H	60
SS-TSE-3060	60" W x 30" D x 2" H	78
SS-TSE-3072	72" W x 30" D x 2" H	109

## PLAN VIEW

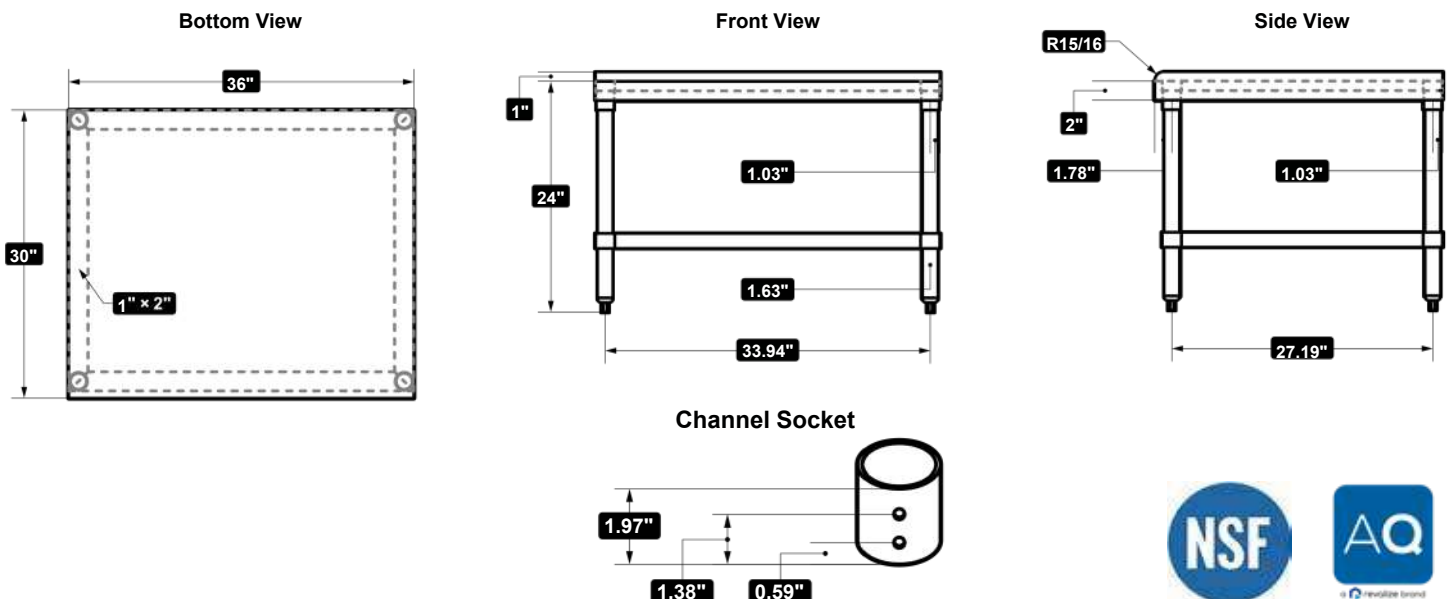



Toll free +1 (833) 978 8833  
 sales@mckequipment.ca  
 Visit [mckonline.ca](http://mckonline.ca) for more details

Quality Kitchen  
 Equipment & Supplies



# Wall Shelf

## FEATURES

- 18 gauge, 430 stainless steel table
- Easy to assemble



## SPECIFICATIONS

Model	Dimensions (WDH Inch)	Weight (lbs)
SS-WS1224-CWP	24" W x 12" D x 3" H	11
SS-WS1236-CWP	36" W x 12" D x 3" H	12
SS-WS1248-CWP	48" W x 12" D x 3" H	13
SS-WS1260-CWP	60" W x 12" D x 3" H	15
SS-WS1272-CWP	72" W x 12" D x 3" H	18
SS-WS1284-CWP	84" W x 12" D x 3" H	21
SS-WS1296-CWP	96" W x 12" D x 3" H	24
SS-WS1424-CWP	24" W x 14" D x 3" H	13
SS-WS1436-CWP	36" W x 14" D x 3" H	14
SS-WS1448-CWP	48" W x 14" D x 3" H	15
SS-WS1460-CWP	60" W x 14" D x 3" H	17
SS-WS1472-CWP	72" W x 14" D x 3" H	20
SS-WS1484-CWP	84" W x 14" D x 3" H	24
SS-WS1496-CWP	96" W x 14" D x 3" H	27
SS-WS1648-CWP	48" W x 16" D x 3" H	16
SS-WS1660-CWP	60" W x 16" D x 3" H	20
SS-WS1672-CWP	72" W x 16" D x 3" H	24
SS-WS1696-CWP	96" W x 16" D x 3" H	32

## PLAN VIEW

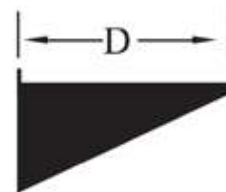
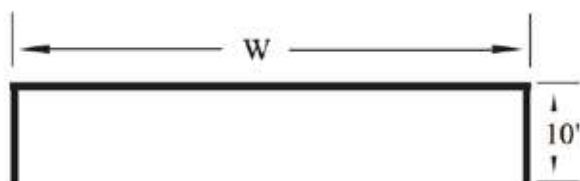



Toll free +1 (833) 978 8833  
 sales@mckequipment.ca  
 Visit [mckonline.ca](http://mckonline.ca) for more details

Quality Kitchen  
 Equipment & Supplies



# Slant Rack

## FEATURES

- 18 Gauge, 304 Series Stainless Steel
- Wall mount
- From 1 to 3 Dish Racks



## SPECIFICATIONS

Model	Rack Size	Dimensions (WDH Inch)	Weight (lbs)
SS-SR-21	21"	21" W x 18" D x 11¼" H	13
SS-SR-42	42"	42" W x 18" D x 11¼" H	21
SS-SR-63	63"	63" W x 18" D x 11¼" H	29

## PLAN VIEW

SS-SR-21

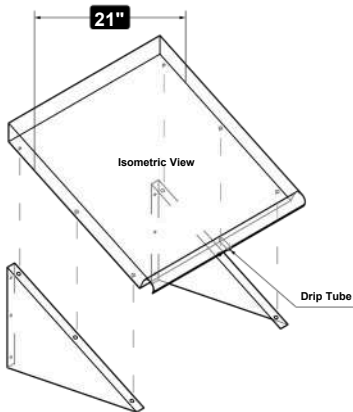

SS-SR-42

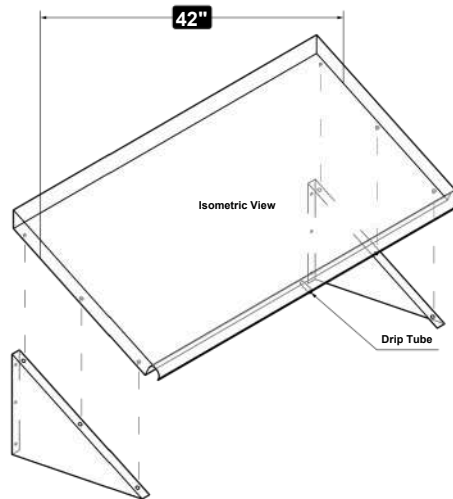

SS-SR-63

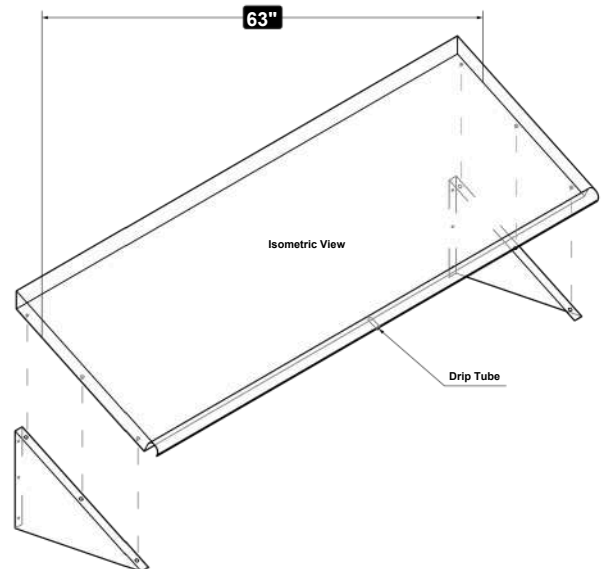



Toll free +1 (833) 978 8833  
 sales@mckequipment.ca  
 Visit [mckonline.ca](http://mckonline.ca) for more details

Quality Kitchen  
 Equipment & Supplies



# Microwave Shelves

## FEATURES

- 18 Gauge 304 Series Stainless Steel



## SPECIFICATIONS

Model	Dimensions (WDH Inch)	Weight (lbs)
SS-MS1824-CWP	24" W x 18" D x 10" H	27
SS-MS2424-CWP	24" W x 24" D x 10" H	30

## PLAN VIEW

SS-MS1824-CWP

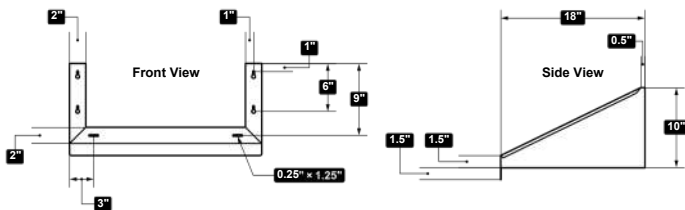
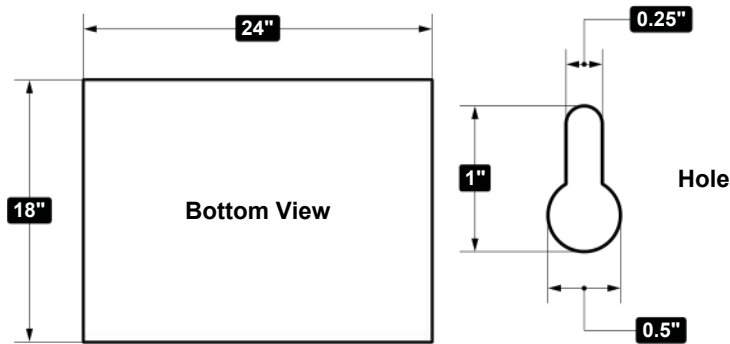

SS-MS2424-CWP

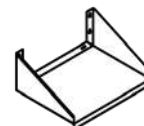
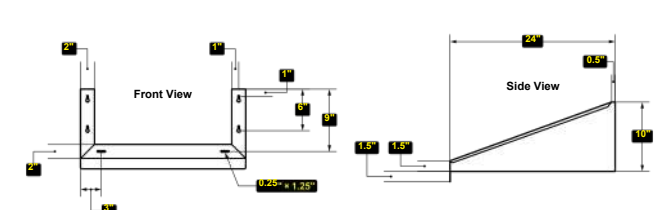
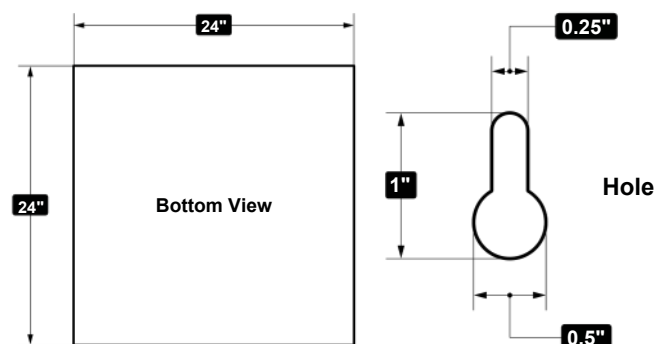



Toll free +1 (833) 978 8833  
 sales@mckequipment.ca  
 Visit [mckonline.ca](http://mckonline.ca) for more details

Quality Kitchen  
 Equipment & Supplies



# Pan Racks

## FEATURES

- Full / half size pan rack
- 304 S/S construction
- Resists corrosion in high moisture refrigerated environments



## SPECIFICATIONS

Model	Shelf/Ledge Spacing	Capacity (18 x 26 size sheet pan)	Dimensions (WDH Inch)	Weight (lbs)
SS-TSP-2224	3 1/4 (83 mm)	6	21" x 24" x 50"	19
SS-TSP-2250	3 (76 mm)	15	21" x 24" x 22 1/2"	41

## PLAN VIEW

SS-TSP-2224

SS-TSP-2250

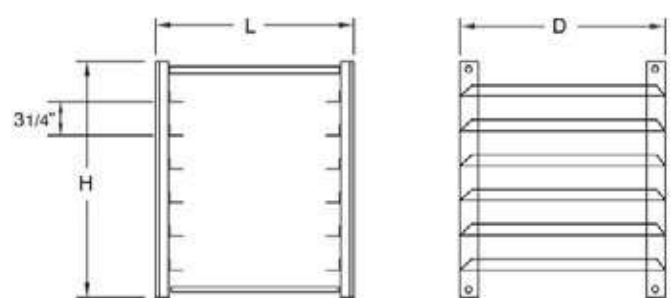
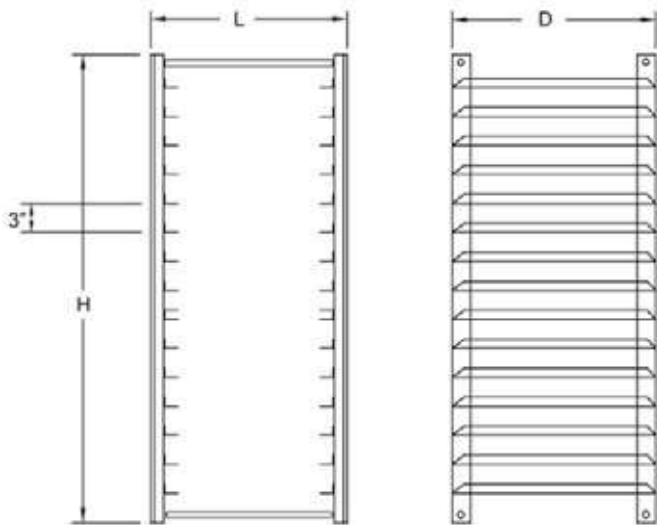



Toll free +1 (833) 978 8833  
 sales@mckequipment.ca  
 Visit [mckonline.ca](http://mckonline.ca) for more details

Quality Kitchen  
 Equipment & Supplies



# Wall Mount Hand Sinks

## FEATURES

- 18Gauge, 304Series S/STop
- Comes with faucet, basket strainer, & mounting bracket
- With or without Side Splash



## SPECIFICATIONS

Model	Side Splash	Back Splash	# Bowls	Bowl Depth	Bowl Size (WDH Inch)	Dimensions (WDH Inch)	Weight (lbs)
SS-HS1410	-	Yes	1	4"	14" x 10" x 5.5"	17" x 15" x 13.5"	13
SS-HS14S-KS	One side	Yes	1	5.5"	14" x 10" x 5.5"	17" x 15" x 13.5"	15
SS-HS15-KS	Two sides	Yes	1	5.5"	14" x 10" x 5.5"	17" x 15" x 13.5"	18

## PLAN VIEW

SS-HS1410



SS-HS14S-KS



SS-HS15-KS

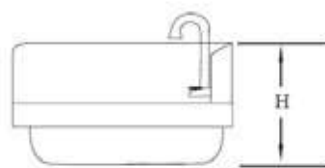
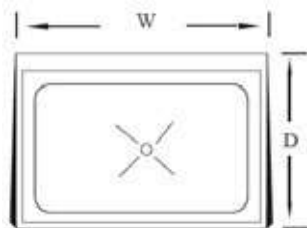



Toll free +1 (833) 978 8833  
 sales@mckequipment.ca  
 Visit [mckonline.ca](http://mckonline.ca) for more details

Quality Kitchen  
 Equipment & Supplies



# Foot Operated Hand Sinks

## FEATURES

- High quality 16 gauge 304S/s.
- 7.75" backsplash
- 34" pedestal.



## SPECIFICATIONS

Model	Side Splash	Back Splash	# Bowls	Bowl Depth	Bowl Size (WDH Inch)	Dimensions (WDH Inch)	Weight (lbs)
SS-FB	No	Yes	1	5.75"	16" x 13.75" x 5.75"	22" x 18" x 43"	50
-	Yes	Yes	1	5.75"	16" x 13.75" x 5.75"	22" x 18" x 43"	05

## PLAN VIEW

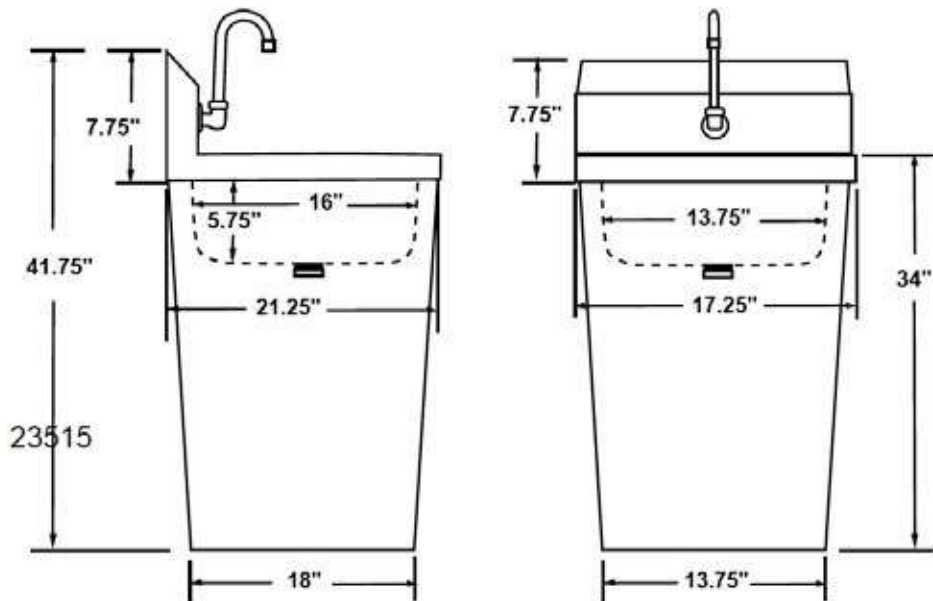



Toll free +1 (833) 978 8833  
 sales@mckequipment.ca  
 Visit [mckonline.ca](http://mckonline.ca) for more details

Quality Kitchen  
 Equipment & Supplies



# Knee Operated Hand Sinks

## FEATURES

- High quality 18 gauge 304 S/S construction
- Knee operated hand sink with 4" low lead gooseneck faucet
- 1-1/2" drain basket



## SPECIFICATIONS

Model	Side Splash	Back Splash	# Bowls	Bowl Depth	Bowl Size (WDH Inch)	Dimensions (WDH Inch)	Weight (lbs)
SS-KB	No	Yes	1	5"	14" x 10" x 5"	14" x 18" x 15.2"	23
-	Yes	Yes	1	5"	14" x 10" x 5"	14" x 18" x 15.2"	23

## PLAN VIEW

SS-HS1410

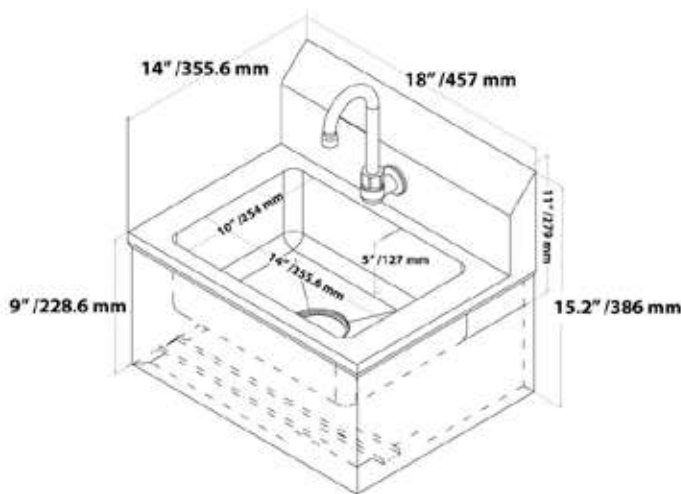

SS-HS14S-KS

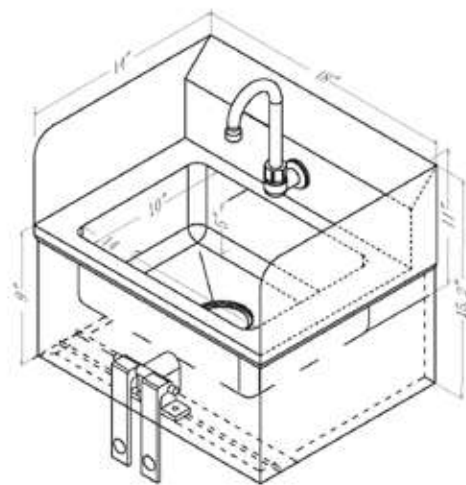



Toll free +1 (833) 978 8833  
 sales@mckequipment.ca  
 Visit [mckonline.ca](http://mckonline.ca) for more details

Quality Kitchen  
 Equipment & Supplies



# Single Compartment Sink

## FEATURES

- 304 Series Stainless Steel
- 18 Gauge Construction
- Stainless Steel Gussets
- 18"-24" Deep Bowls Welded Together
- 9 1/2" Backsplash (11 3/4" from Deck to Tile Edge)
- Galvanized Legs with Adjustable Feet
- Basket Strainers Included



SS-EICWP1616 | SS-EICWP1818 | SS-EICWP2424



SS-EICWP1818L | SS-EICWP2424L



SS-EICWP1818R | SS-EICWP2424R





## SPECIFICATIONS

Model	Drain Boards	Bowl Dimensions (WD inch)	Dimensions (WDH inch)	Weight (lbs)
SS-EICWP1616	-	16" x 14"	23" x 23.5"	53
SS-EICWP1818	-	18" x 14"	23" x 23.5"	57
SS-EICWP1818L	18" Left	18" x 14"	38.5" x 23.5"	65
SS-EICWP1818R	18" Right	18" x 14"	38.5" x 23.5"	65
SS-EICWP2424	-	24" x 14"	29" x 29.5"	78
SS-EICWP2424DD	Two 24"	24" x 14"	50.5" x 29.5"	78
SS-EICWP2424L	24" Left	24" x 14"	50.5" x 29.5"	78
SS-EICWP2424R	24" Right	24" x 14"	50.5" x 29.5"	78

## PLAN VIEW

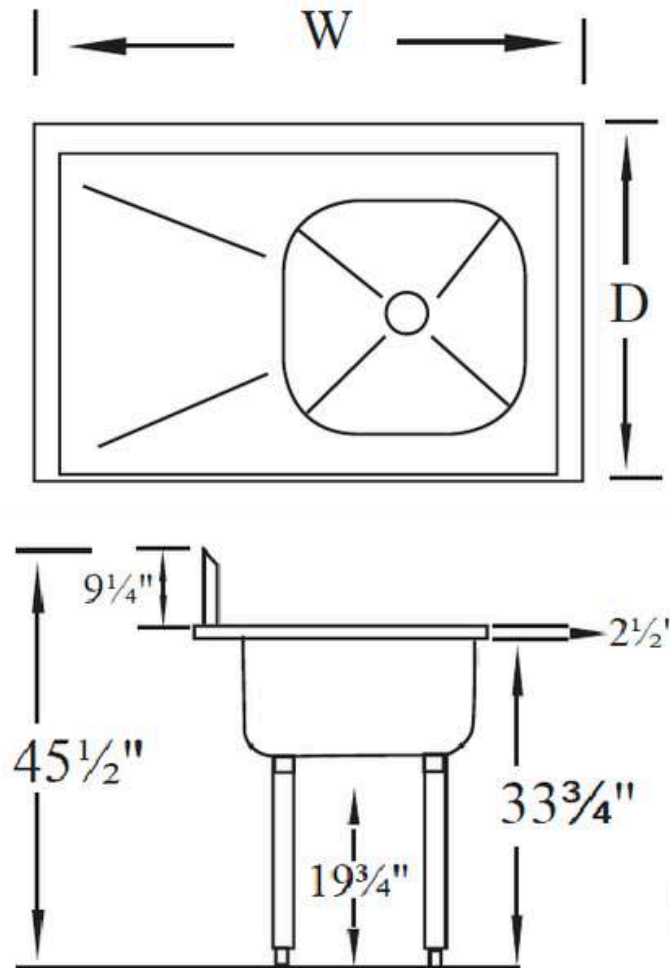



Toll free +1 (833) 978 8833  
 sales@mckequipment.ca  
 Visit [mckonline.ca](http://mckonline.ca) for more details

Quality Kitchen  
 Equipment & Supplies



# Double Compartment Sink

## FEATURES

- 304Series StainlessSteel
- 18 Gauge Construction • Stainless Steel Gussets • 18"-24" Deep Bowls Welded Together • 9 1/2" Backsplash (11 3/4" from deck to tile edge)
- Galvanized Legs with Adjustable Feet
- Basket Strainers Included



SS-E2CWP1818



SS-E2CWP1818L | SS-E2CWP1818R



SS-E2CWP2424DD





## SPECIFICATIONS

Model	Drain Boards	Bowl Dimensions (WD inch)	Dimensions (WDH inch)	Weight (lbs)
SS-E2CWP1818	-	18" x 18"	23.5" x 41"	75
SS-E2CWP1818D	Two 18"	18" x 18"	23.5" x 72"	126
SS-E2CWP1818L	18" Left	18" x 18"	23.5" x 56.5"	101
SS-E2CWP1818R	18" Right	18" x 18"	23.5" x 56.5"	101
SS-E2CWP2424	-	24" x 24"	29.5" x 53"	80
SS-E2CWP2424DD	Two 24"	24" x 24"	29.5" x 96"	136
SS-E2CWP2424L	24" Left	24" x 24"	29.5" x 74.5"	89
SS-E2CWP2424LD	24" Left	24" x 24"	29.5" x 74.5"	89
SS-E2CWP2424R	24" Right	24" x 24"	29.5" x 74.5"	89
SS-E2CWP2424RD	24" Right	24" x 24"	29.5" x 74.5"	89

## PLAN VIEW

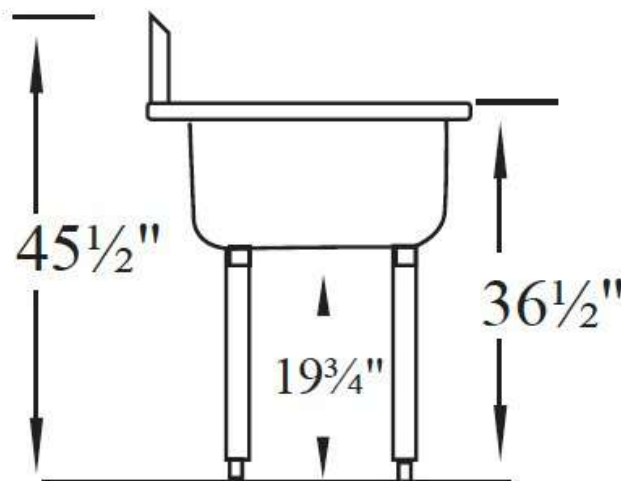
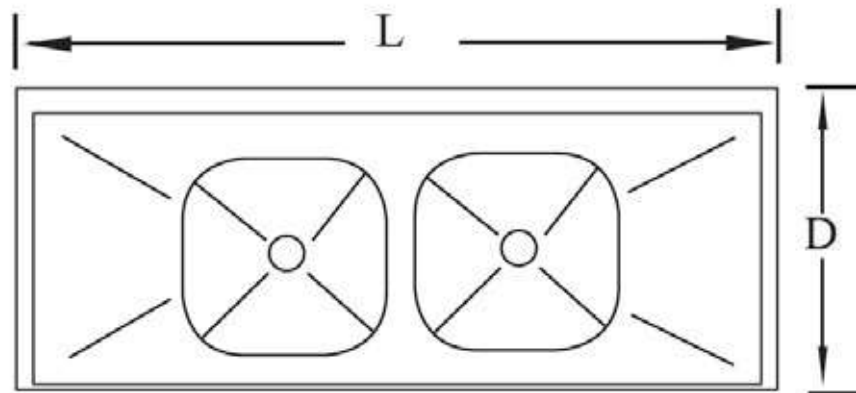



Toll free +1 (833) 978 8833  
 sales@mckequipment.ca  
 Visit [mckonline.ca](http://mckonline.ca) for more details

Quality Kitchen  
 Equipment & Supplies



# Triple Compartment Sink

## FEATURES

- 304 Series Stainless Steel
- 18 Gauge Construction
- Stainless Steel Gussets
- 18"-24" Deep Bowls Welded Together
- 9 1/2" Backsplash (11 3/4" from Deck to Tile Edge)
- Galvanized Legs with Adjustable Feet
- Basket Strainers Included



SS-E3CWP1818 | SS-E3CWP2424



SS-E3CWP1818L | SS-E3CWP1818R





## SPECIFICATIONS

Model	Drain Boards	Bowl Dimensions (WDH inch)	Dimensions (WDH inch)	Weight (lbs)
SS-E3CWP1818	-	15" x 15" x 14"	50" x 20.5" x 45.5"	133
SS-E3CWP1818L	15" Left	15" x 15" x 14"	62.5" x 20.5" x 45.5"	158
SS-E3CWP1818R	15" Right	15" x 15" x 14"	62.5" x 20.5" x 45.5"	158
SS-E3CWP1818LR	Two 15"	15" x 15" x 14"	75" x 20.5" x 45.5"	175
SS-E3CWP2424	-	24" x 24" x 14"	77" x 29.5" x 45.5"	180
SS-E3CWP2424L	Two 24"	24" x 24" x 14"	120" x 29.5" x 45.5"	215
SS-E3CWP2424R	24" Left	18" x 24" x 14"	80.5" x 29.5" x 45.5"	120
SS-E3CWP2424LR	24" Right	18" x 24" x 14"	80.5" x 29.5" x 45.5"	120

## PLAN VIEW

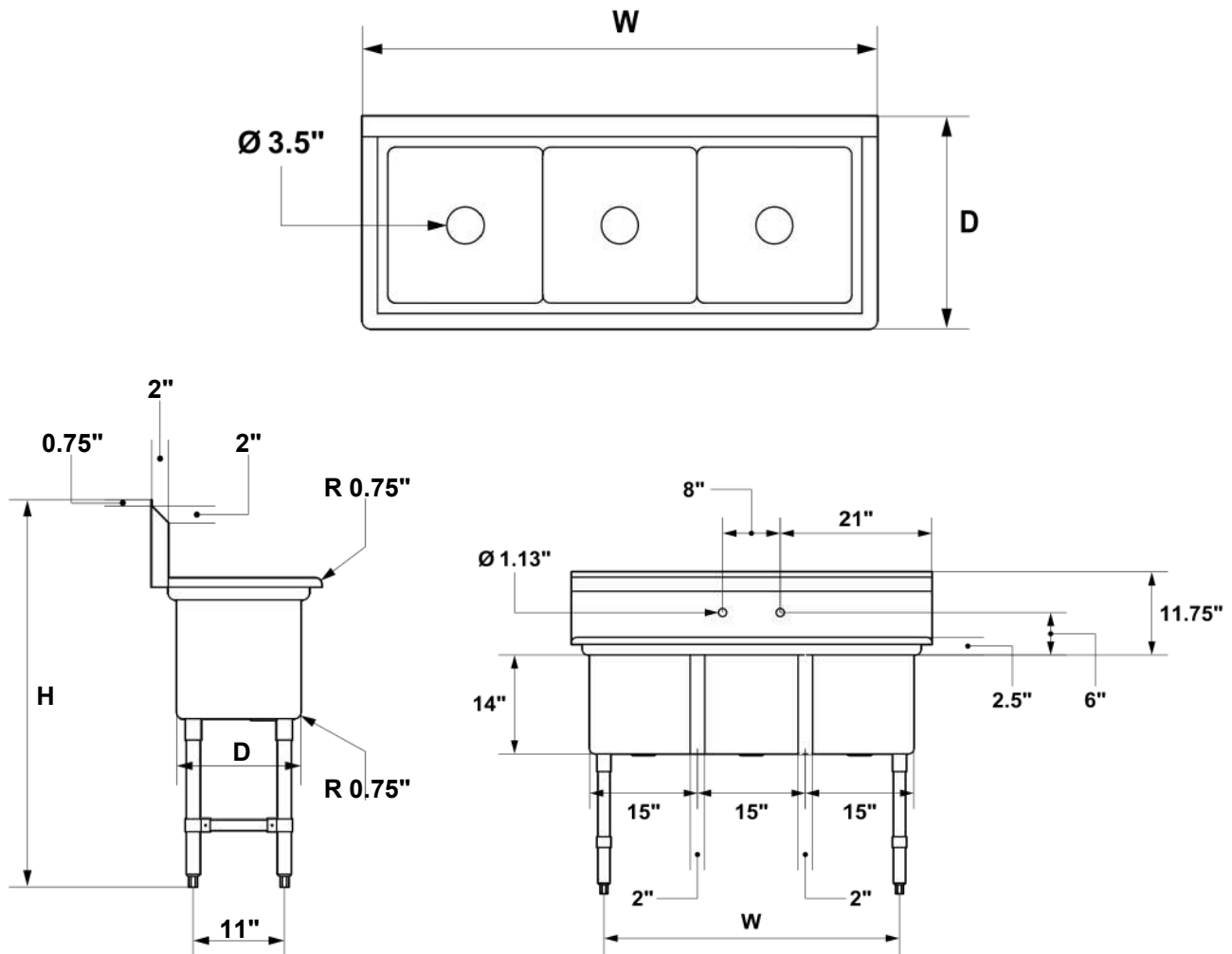



Toll free +1 (833) 978 8833  
sales@mckequipment.ca  
Visit [mckonline.ca](http://mckonline.ca) for more details

Quality Kitchen  
Equipment & Supplies



# Deep Corner Triple Comp. Sink

## FEATURES

- 304 Series Stainless Steel
- 18 Gauge Construction
- Stainless Steel Gussets
- Cut for 2 faucets
- 18" Deep Bowls Welded Together
- 9 1/2" Backsplash (11 3/4" from Deck to Tile Edge)
- Galvanized Legs with Adjustable Feet
- Basket Strainers Included



SS-CS43073



### SPECIFICATIONS

Model	Drain Boards	Bowl Dimensions (WDH inch)	Dimensions (WDH inch)	Weight (lbs)
SS-CS43073	Two 18"	18" x 18" x 14"	57" x 57" x 45.5"	111

### PLAN VIEW

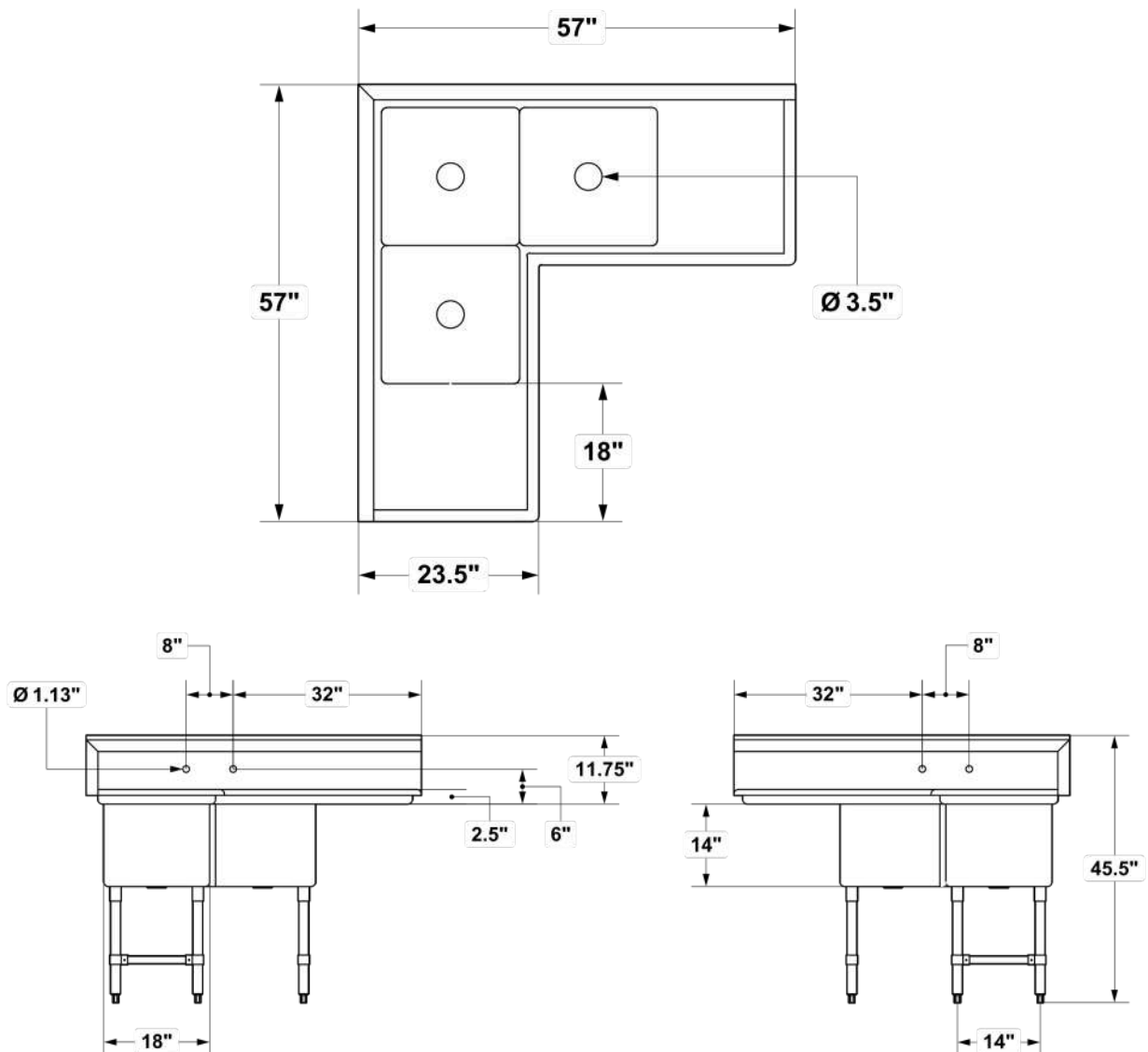



Toll free +1 (833) 978 8833  
sales@mckequipment.ca  
Visit [mckonline.ca](http://mckonline.ca) for more details

Quality Kitchen  
Equipment & Supplies



# Clean Dish Tables (30" Depth Series)

## FEATURES

- 304 Series Stainless Steel
- 16 Gauge Construction
- 4 1/2" Backsplash (11" from Deck to Tile Edge)
- 6" Deep Bowls
- 1 5/8" Galvanized Legs with Adjustable Foot
- Left and Right Models Available





Toll free +1 (833) 978 8833  
 sales@mckequipment.ca  
 Visit [mckonline.ca](http://mckonline.ca) for more details

### SPECIFICATIONS

Model	Orientation	Bowl Dimensions (WDH inch)	Width (inch)	Weight (lbs)
SS-CSDT-60L-C	Left	20" x 20" x 6"	60"	68
SS-CSDT-60R-C	Right			

### PLAN VIEW

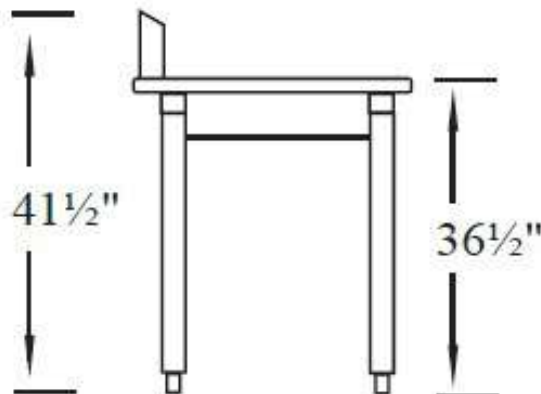
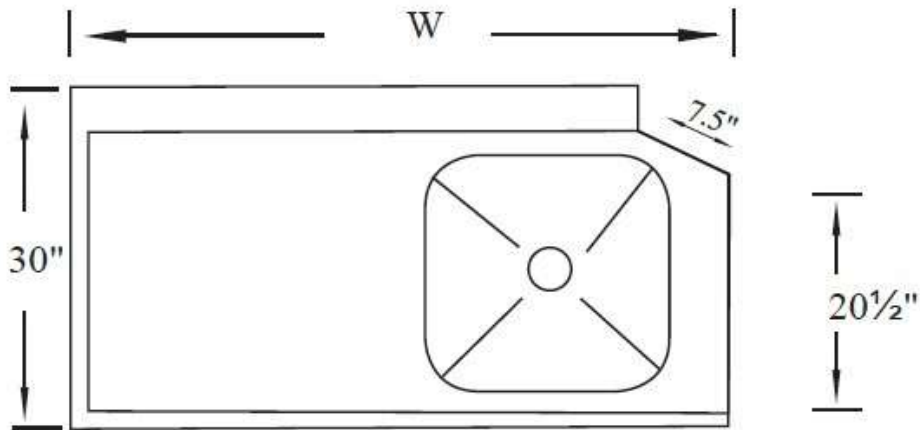



Toll free +1 (833) 978 8833  
sales@mckequipment.ca  
Visit [mckonline.ca](http://mckonline.ca) for more details

Quality Kitchen  
Equipment & Supplies



# Clean Dish Tables (30" Depth Series)

## FEATURES

- 304 Series Stainless Steel
- 16 Gauge Construction
- 4½" Backsplash (11" from Deck to Tile Edge)
- 1 5/8" Galvanized Legs with Adjustable Feet
- Left and Right Models Available





### SPECIFICATIONS

Model	Orientation	Width (inch)	Weight (lbs)
SS-CDT24L-CWP	Left	24"	32
SS-CDT24R-CWP	Right		
SS-CDT36L-CWP	Left	36"	41
SS-CDT36R-CWP	Right		
SS-CDT48L-CWP	Left	48"	53
SS-CDT48R-CWP	Right		
SS-CDT60L-CWP	Left	60"	63
SS-CDT60R-CWP	Right		

### PLAN VIEW

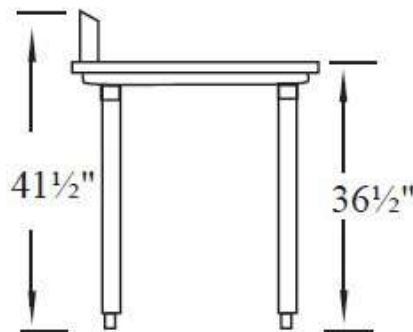
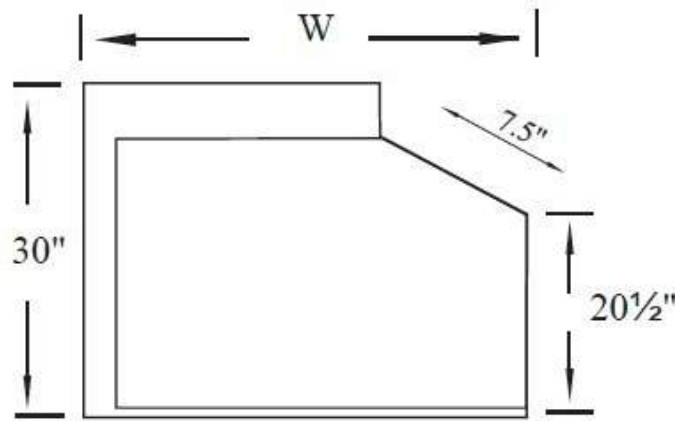



Toll free +1 (833) 978 8833  
 sales@mckequipment.ca  
 Visit [mckonline.ca](http://mckonline.ca) for more details



# Bar Sinks with 1 to 4 Bowls >

## GENERAL FEATURES

- Equipped with drain guards and corner drain
- Faucet holes are 1 inch (4-inch apart) on center
- Shipped with legs removed
- 18 gauge 304 stainless steel

## FEATURES | SS-BAR1B14

- 18 Gauge 304 Stainless Steel Top, Bowl and Back
- 1 Compartment
- No drain board

SS-BAR1B14



## FEATURES | SS-BAR3B38

- 18 Gauge 304 Stainless Steel Top, Bowl and Back
- 3 Compartment

SS-BAR3B38



## FEATURES | SS-BAR3B38-L

- 18 Gauge Top, Bowl and Back
- 20 Gauge Apron
- 3 Compartment

SS-BAR3B38-L



## FEATURES | SS-BAR3B48-R

- 18 Gauge Top, Bowl and Back
- 20 Gauge Apron
- 3 Compartment

SS-BAR3B38-R





Toll free +1 (833) 978 8833  
 sales@mckequipment.ca  
 Visit [mckonline.ca](http://mckonline.ca) for more details

Quality Kitchen  
 Equipment & Supplies



# < Bar Sinks with 1 to 4 Bowls

## FEATURES | SS-BAR3B60-LR

- 18 Gauge Top, Bowl and Back
- 20 Gauge Apron
- 3 Compartment



SS-BAR3B60-LR

## FEATURES | SS-BAR3B72-LR

- 18 Gauge Top, Bowl and Back
- 20 Gauge Apron
- 3 Compartment



SS-BAR3B70-LR

## FEATURES | SS-BAR4B72-LR

- 18 Gauge Top, Bowl and Back
- 20 Gauge Apron
- 4 Compartment



SS-BAR4B60-LR





## SPECIFICATIONS

Model	Drain Boards	Drain Boards Size	# Bowls	Bowl Dimensions (WDH Inch)	Net Dimensions (WDH Inch)	Weight (lbs)
SS-BARIB14	-		1	10" x 14" x 10"	14.5" x 18.75" x 33"	40
SS-BAR3B38	-		3	10" x 14" x 10"	38.5" x 18.75" x 33"	65
SS-BAR3B48-L	Left	12"	3	10" x 14" x 10"	48" x 18.75" x 33"	64
SS-BAR3B48-R	Right	12"	3	10" x 14" x 10"	48" x 18.75" x 33"	64
SS-BAR3B60-LR	Double	12"	3	10" x 14" x 10"	60" x 18.75" x 33"	83
SS-BAR3B72-LR	Double	19"	3	10" x 14" x 10"	72" x 18.75" x 33"	95
SS-BAR4B72-LR	Double	13"	4	10" x 14" x 10"	72" x 18.75" x 33"	95

## PLAN VIEW >

SS-BARIB14

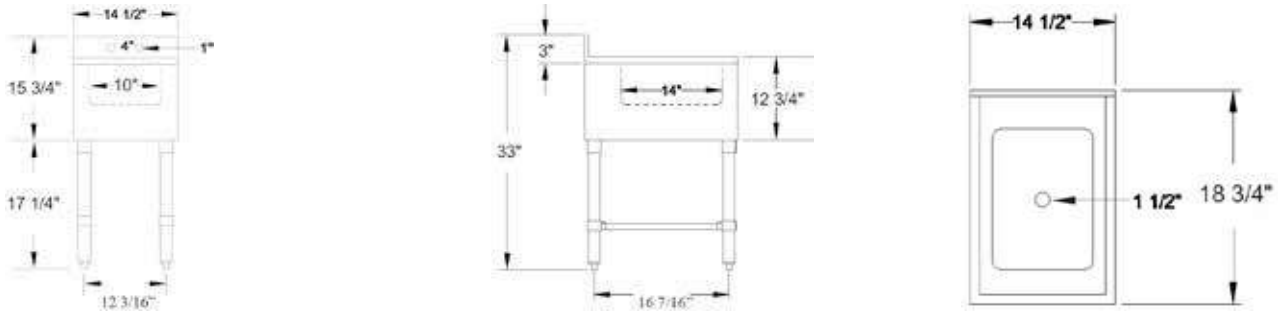

SS-BAR3B38

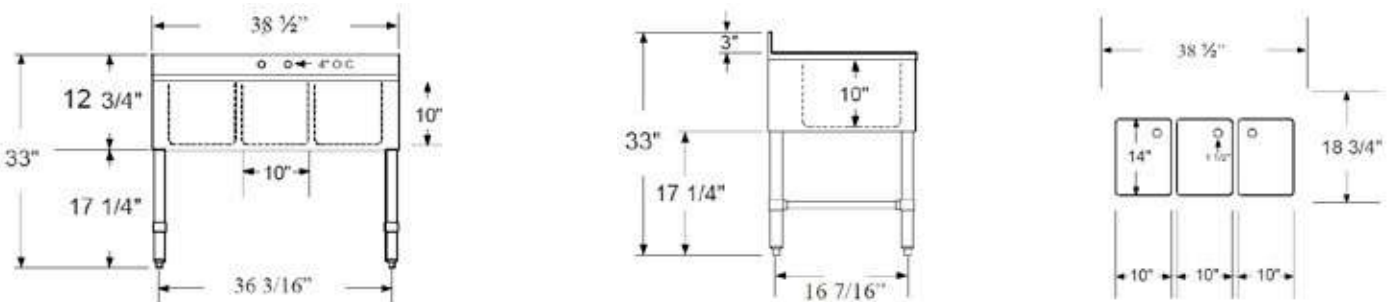

SS-BAR3B48-L

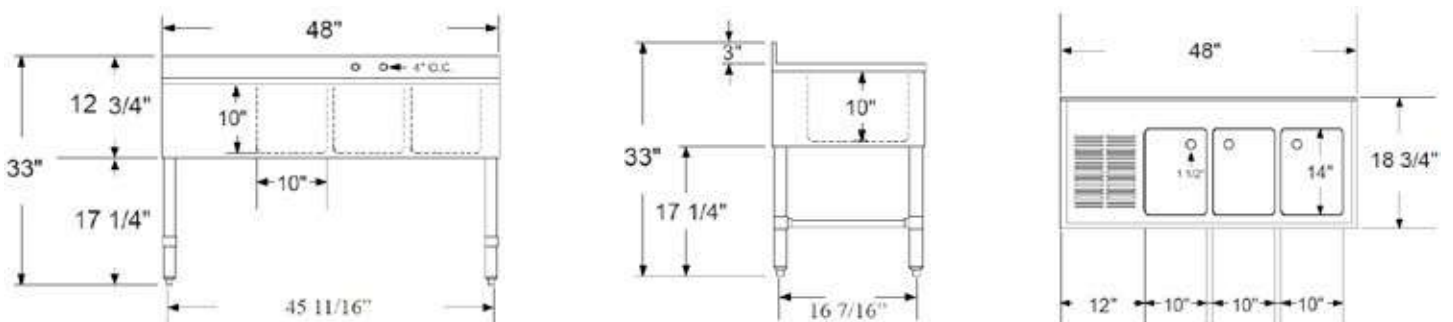



PLAN VIEW

SS-BAR3B48-R

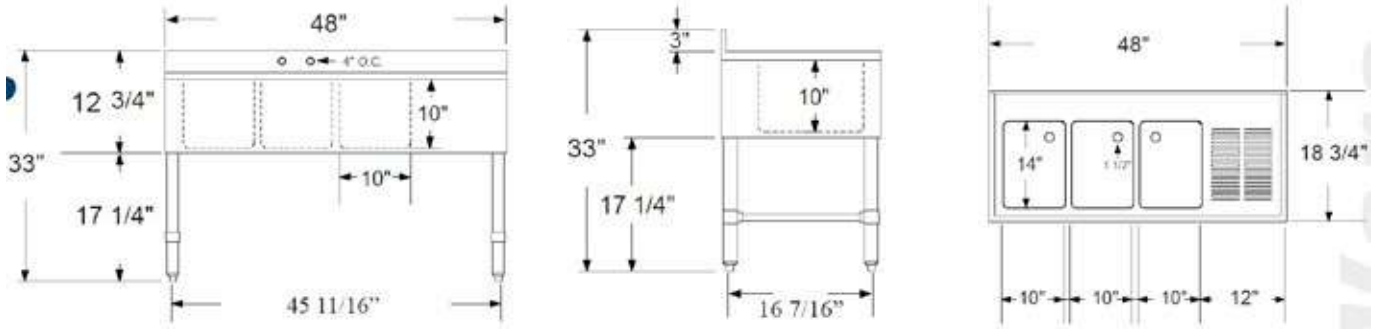

SS-BAR3B60-LR

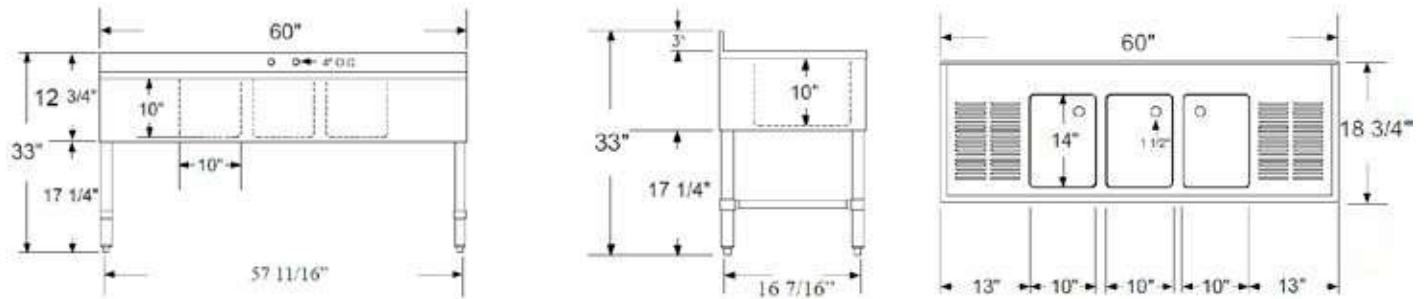

SS-BAR3B72-LR

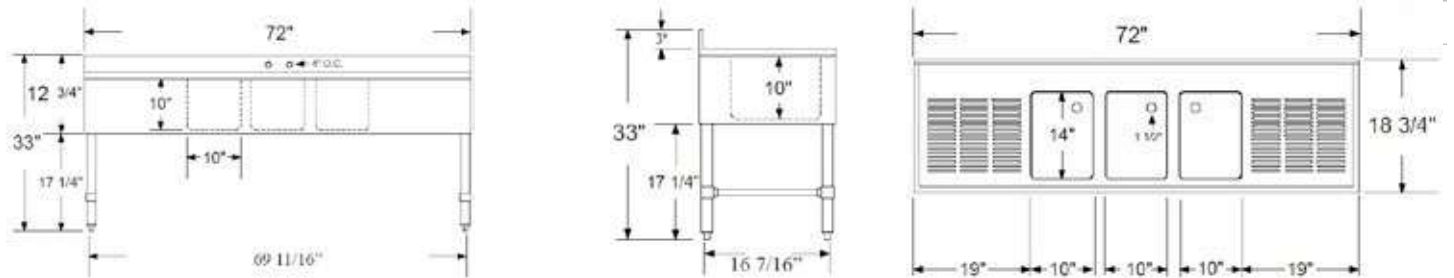

SS-BAR4B72-LR

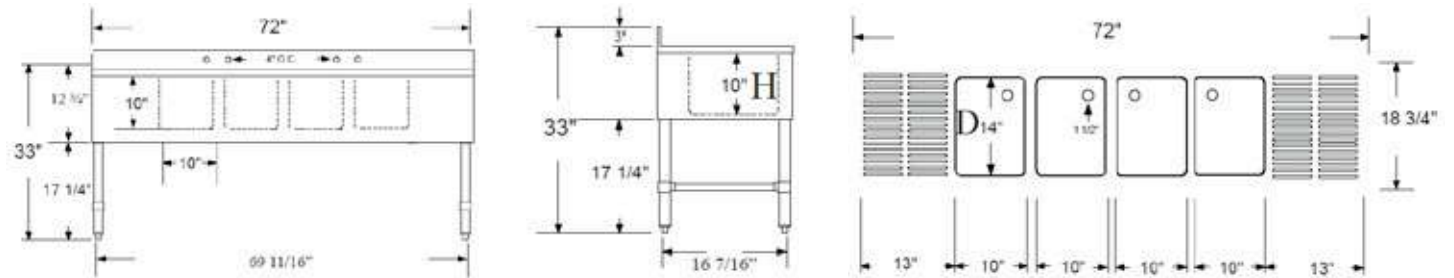



# Mop Sinks

## FEATURES

- T-304 16 Gauge Stainless Steel
- 3 Skirted Sides
- Floor Mounted



## SPECIFICATIONS

Model	Mount Type	Bowl Depth	Dimensions (WDH Inch)	Weight (lbs)
SS-MS1620-CWP	-	6"	16" x 20" x 6"	64
SS-MS2125	-	12"	21" x 25" x 6"	46.2
SS-MS2424	-	6"	24" x 24" x 6"	46.2
SS-MS2533	-	6"	25" x 33" x 6"	46.2
SS-MS2024	Floor Mount	12"	24" x 20" x 6"	76

## PLAN VIEW

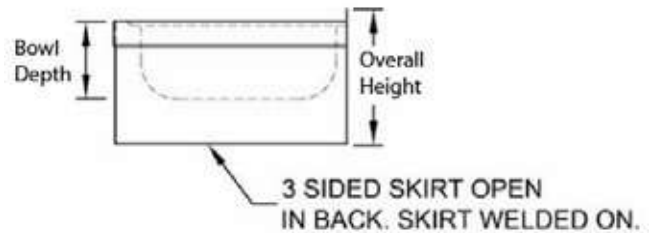
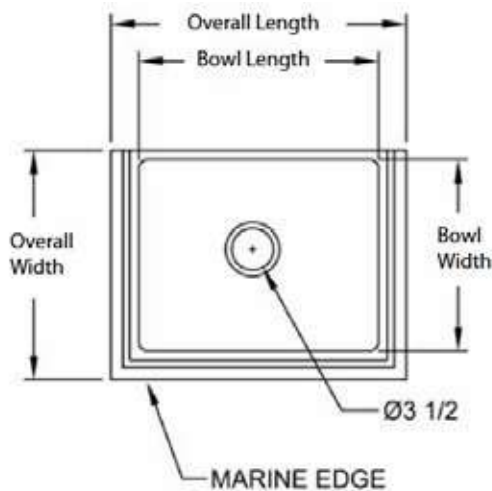



Toll free +1 (833) 978 8833  
 sales@mckequipment.ca  
 Visit [mckonline.ca](http://mckonline.ca) for more details

Quality Kitchen  
 Equipment & Supplies



# Ice Bin

## FEATURES

- 20-gauge 304 stainless steel bowl, top, back and body
- Galvanized leg and socket, plastic bullet feet and
- "U" shape leg bracing
- 3" high backsplash



## SPECIFICATIONS

Model	Capacity (lbs)	Bowl Dimensions (WDH Inch)	Dimensions (WDH Inch)	Weight (lbs)
SS-IB1824	77	22" x 14.8" x 12"	18" x 24"	64
SS-IB1830	98	28" x 14.8" x 12"	18" x 30"	72
SS-IB1836	119	34" x 14.8" x 12"	18" x 36"	79.2

## PLAN VIEW

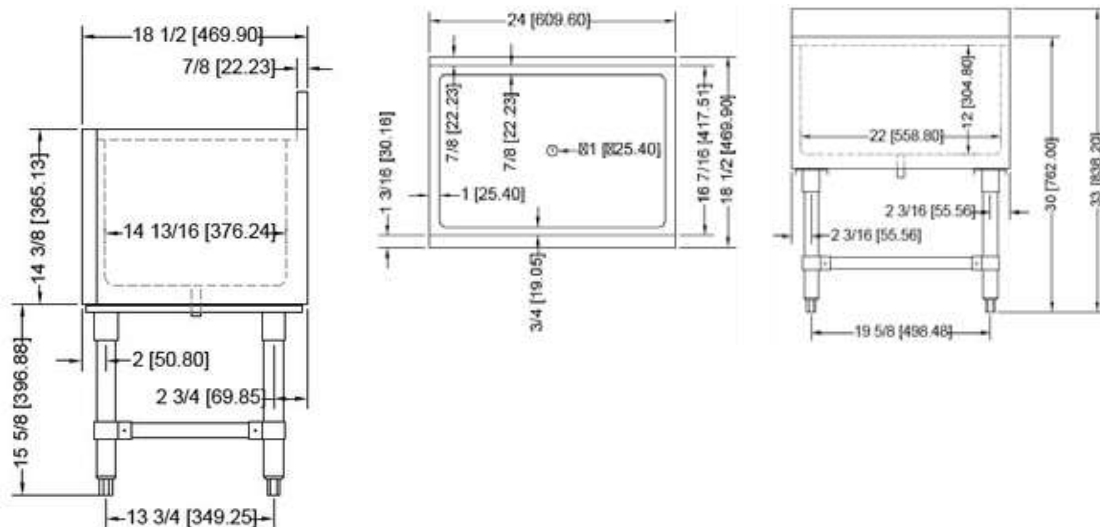



Toll free +1 (833) 978 8833  
 sales@mckequipment.ca  
 Visit [mckonline.ca](http://mckonline.ca) for more details



# Pre-Rinse Basket



SS-B2025-CWP | SS-CPRB-CWP

## FEATURES

- 304 Series Stainless Steel
- 16 Gauge Construction
- Sized for Standard 20" x 20"
- Welded Slide Bars



Drain Hole Configuration

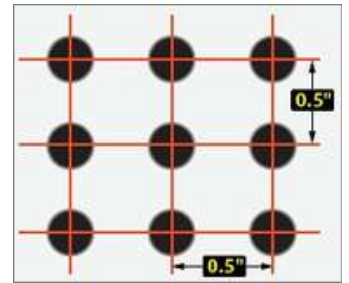

Basket is provided with hole spacing pattern as illustrated. **All holes are 1/8" DIAMETER**

SS-B2025-CWP

## SPECIFICATIONS

Model	Spacing Between Holes	Hole Size	Dimensions (WDH Inch)	Net Weight (lbs)
SS-B2025-CWP	0.5"	1/8"	20" x 25" x 5"	15
SS-CPRB-CWP	0.5"	1/8"	19.5" x 19.5" x 5"	11

## PLAN VIEW

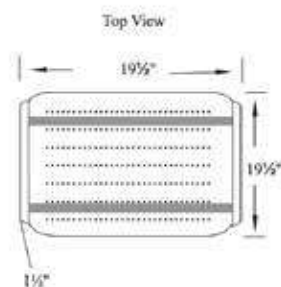

Side View

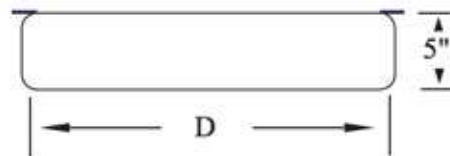



Toll free +1 (833) 978 8833  
 sales@mckequipment.ca  
 Visit [mckonline.ca](http://mckonline.ca) for more details

# Aluminum Dunnage Rack

SS-ADR-22125

## FEATURES

- Store products off the floor to maintain sanitation and prevent damage.
- Constructed from welded 1 1/2 inch square aluminum tubing for maximum strength and durability.
- Shipped fully assembled and ready for immediate use.



## SPECIFICATIONS

Model	Loading Capacity	Dimensions (WDH Inch)	Net Weight (lbs)
SS-ADR-22125	1600 lbs	22" x 36" x 12"	7

## PLAN VIEW

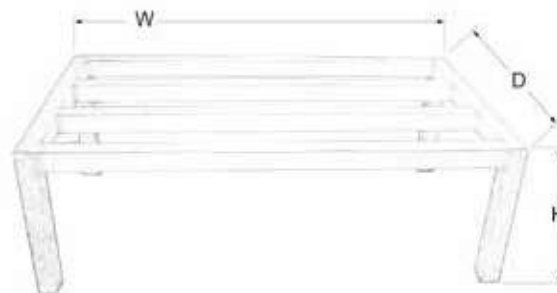



Toll free +1 (833) 978 8833  
 sales@mckequipment.ca  
 Visit [mckonline.ca](http://mckonline.ca) for more details

Quality Kitchen  
 Equipment & Supplies



# Knock-Down Worktable with Cabinet

SS-KNOCK 24403

## FEATURES

- Utility Cart
- 304 stainless steel
- 1 1/2" ledge on the shelves
- 4" rubber casters standard



SS-KNOCK 24403

## SPECIFICATIONS

Model	Midshelf Capacity	Top Capacity	Undershelf Capacity	Height	Weight	Package Dimensions (WDH Inch)
SS-KNOCK 24403	260 lbs	690 lbs	420 lbs	38"	125 lbs	50" x 33" x 12"

## PLAN VIEW

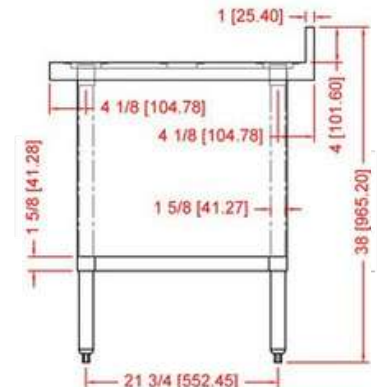
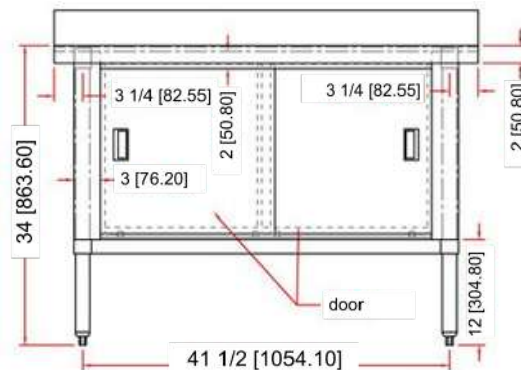
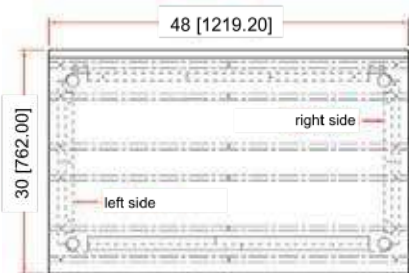



Toll free +1 (833) 978 8833  
 sales@mckequipment.ca  
 Visit [mckonline.ca](http://mckonline.ca) for more details

Quality Kitchen  
 Equipment & Supplies



# Three Level S/s Bus Cart

SS-KBUS-1524E | SS-KBUS-1828E | SS-KBUS-2133E

## FEATURES

- Utility Cart
- 304 stainless steel
- 1 1/2" ledge on the shelves
- 4" rubber casters standard



SS-B2025-CWP

## SPECIFICATIONS

Model	Levels	Dimensions (WDH Inch)	Overall Dimensions (WDH Inch)	Net Weight (lbs)
SS-KBUS-1524E	3	A 24" x B 15" x C 25" x D 16" x E 28 1/2" x F 29"	24" x 15" x 33 1/2"	32
SS-KBUS-1828E		A 28" x B 18" x C 28 7/8" x D 18 7/8" x E 32 1/2" x F 29"	28" x 18" x 33 1/2"	37
SS-KBUS-2133E		A 33" x B 21" x C 33 7/8" x D 18 7/8" x E 37 1/2" x F 29"	33" x 21" x 33 1/2"	47

## PLAN VIEW

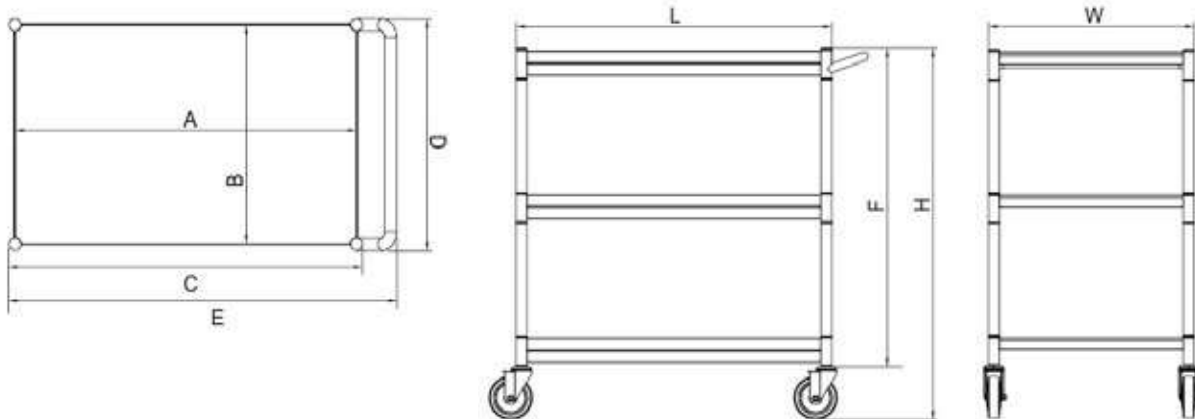

# Electric Cooking Equipment

Electric Egg Boilers  
Electric Crepe Maker  
Electric Waffle Maker  
Electric Conveyor Toaster  
Electric Pasta Cooker Single | Double  
Electric Manual Toaster  
Electric Fryer



Toll free +1 (833) 978 8833  
 sales@mckequipment.ca  
 Visit [mckonline.ca](http://mckonline.ca) for more details

Quality Kitchen  
 Equipment & Supplies



# Electric Egg Boiler

**MCK-GD-EB6 |  
 MCK-GD-EB8  
 Features:**

- Built with high-grade stainless steel for exceptional longevity and easy cleaning
- Adjustable thermostat dial provides precise temperature control for perfect results



**MCK-GD-EB6**



**MCK-GD-EB8**





Toll free +1 (833) 978 8833  
sales@mckequipment.ca  
Visit [mckonline.ca](http://mckonline.ca) for more details

Quality Kitchen  
Equipment & Supplies



### SPECIFICATIONS

<b>Model Number</b>	<b>Size (inches)</b>	<b>Net Weight (lbs)</b>	<b>Gross Weight (lbs)</b>
MCK-GD-EB6	14.76 x 8.66 x 11.42	11.46	13.67
MCK-GD-EB8	14.76 x 8.66 x 11.42	11.46	13.67



Toll free +1 (833) 978 8833  
sales@mckequipment.ca  
Visit [mckonline.ca](http://mckonline.ca) for more details

Quality Kitchen  
Equipment & Supplies



# Electric Crepe Maker

## MCK-GD-CM02



### Features:

- Featuring two cooking plates, this crepe maker enables you to prepare multiple crepes at once, increasing efficiency during busy hours.
- Cooking plates feature a commercial grade non stick surface, delivering smooth and perfectly cooked crepes every time.
- A user friendly thermostatic control lets you adjust temperatures for perfect results, batch after batch.





Toll free +1 (833) 978 8833  
sales@mckequipment.ca  
Visit [mckonline.ca](http://mckonline.ca) for more details

Quality Kitchen  
Equipment & Supplies



### SPECIFICATIONS

<b>Model Number</b>	<b>Size (inches)</b>	<b>Net Weight (lbs)</b>	<b>Gross Weight (lbs)</b>
<b>MCK-GD-CM02</b>	33.86 x 19.69 x 8.66	66.14	70.55



Toll free +1 (833) 978 8833  
 sales@mckequipment.ca  
 Visit [mckonline.ca](http://mckonline.ca) for more details

Quality Kitchen  
 Equipment & Supplies



# Electric Waffle Maker

## MCK-GD-WF-2

- Independent time and temperature control knobs for precise baking
- High quality stainless steel body with non-stick Teflon coated heating plates
- Heat insulated handles and nonslip feet for safety and stability



### SPECIFICATIONS

Model Number	Size (inches)	Net Weight (lbs)	Gross Weight (lbs)
MCK-GD-WF-2	19.69 x 15.35 x 10.24	28.66	30.86





Toll free +1 (833) 978 8833  
 sales@mckequipment.ca  
 Visit [mckonline.ca](http://mckonline.ca) for more details

Quality Kitchen  
 Equipment & Supplies



# Electric Conveyor Toaster

TT-150 | TT-300 | TT-450



TT-150



TT-300



TT-450





## Description:

- Food grade Stainless Steel Frame
- 304 stainless steel internal chain conveyor
- Easily adjustable settings to achieve the exact texture and color desired
- The removable crumb tray makes post service cleaning fast and hassle free
- Equipped with strategically placed heat emission holes to ensure continuous good heat dissipation and stable performance

### SPECIFICATIONS

Model Number	Size (inches)	Net Weight (lbs)	Gross Weight (lbs)
<b>TT-150</b>	22.05 x 11.42 x 16.34	26.46	30.86
<b>TT-300</b>	22.05 x 14.57 x 16.34	29.10	35.27
<b>TT-450</b>	22.05 x 18.50 x 16.34	67.24	73.85



Toll free +1 (833) 978 8833  
 sales@mckequipment.ca  
 Visit [mckonline.ca](http://mckonline.ca) for more details

Quality Kitchen  
 Equipment & Supplies



# Electric Pasta Cooker Single | Double

**MCK-GPC-6-1T | MCK-GPC-6-2T**

## FEATURES :

**Compact design** seamlessly integrates into your kitchen setup while offering ample space to cook multiple pasta batches simultaneously.

**Sturdy stainless steel build** guarantees durability and simplifies cleaning and maintenance, essential in bustling kitchen settings.

**Robust 120,000 / 60,000 BTU heating capacity tailored for natural or propane gas** use, ensuring quick heating and consistent, efficient cooking every time.

**Impressive 22 / 11 gallon capacity and 12 / 6 stainless steel baskets** included, you can effortlessly prepare various pasta types or multiple batches with ease.



**MCK-GPC-6-1T**



**MCK-GPC-6-2T**





**SPECIFICATIONS**

Model	Burners	Total BTU	Gas type	Tank capacity	Basket quantity
MCK-GPC-6-1T	1	60,000	Natural (4"W.C) Propane(10"W.C)	11 gallon	6
MCK-GPC-6-2T	2	120,000	Natural (4"W.C) Propane(10"W.C)	11 gallon per tank	12

**PLAN VIEW**

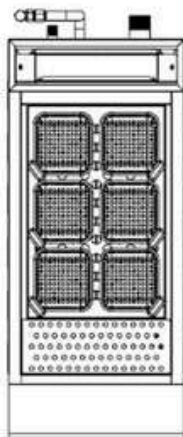
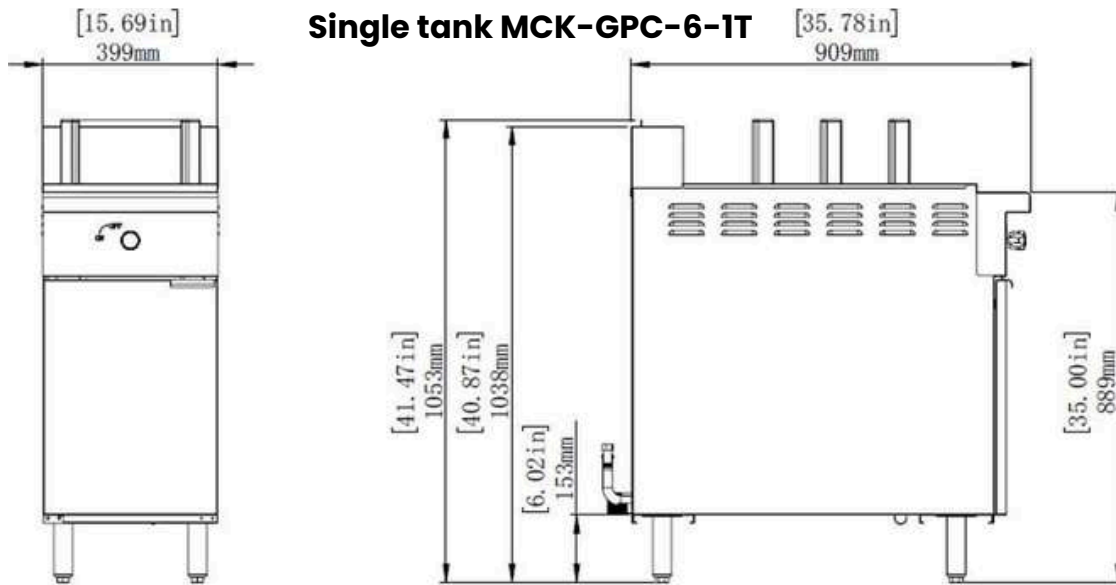



PLAN VIEW

Double tank MCK-GPC-6-2T

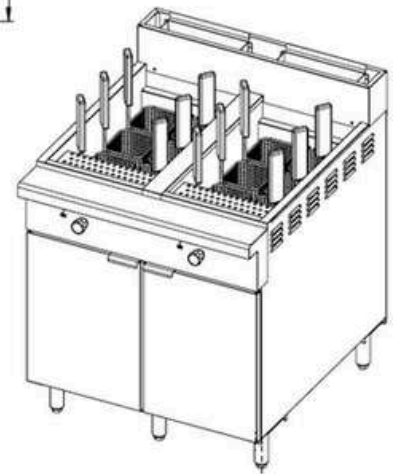
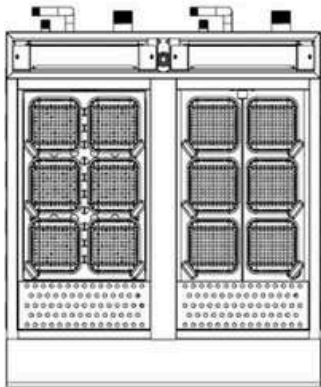
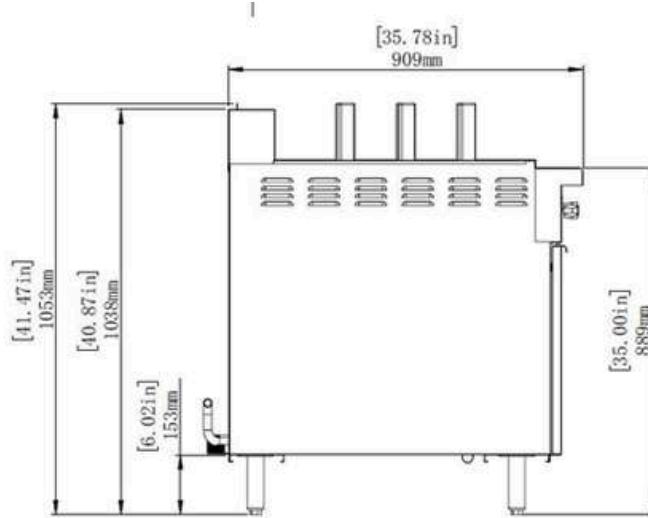
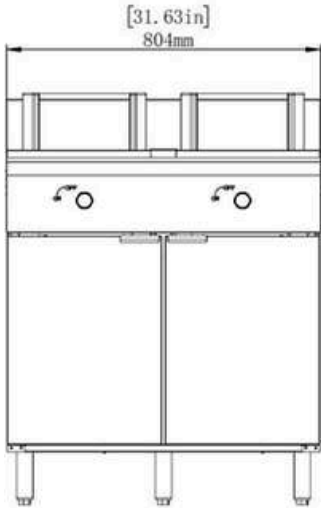



**Features**

**water inlet size is 1/2 inch , the standard inlet water is from the back of the water tank, additional water faucet on top of tank is optional.**

**Overflow protection**

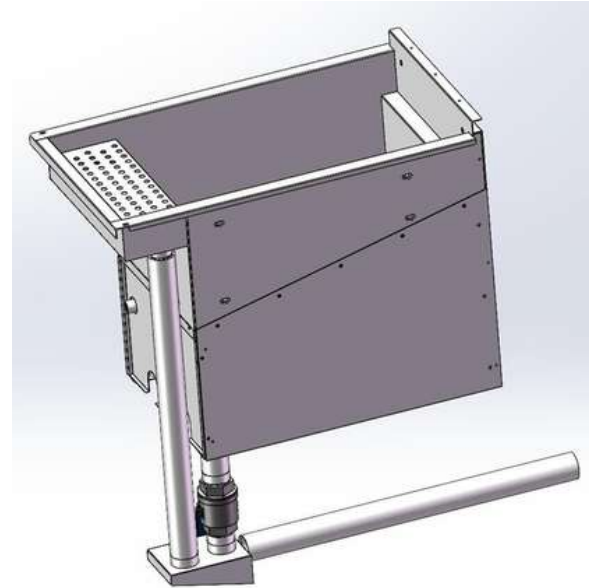
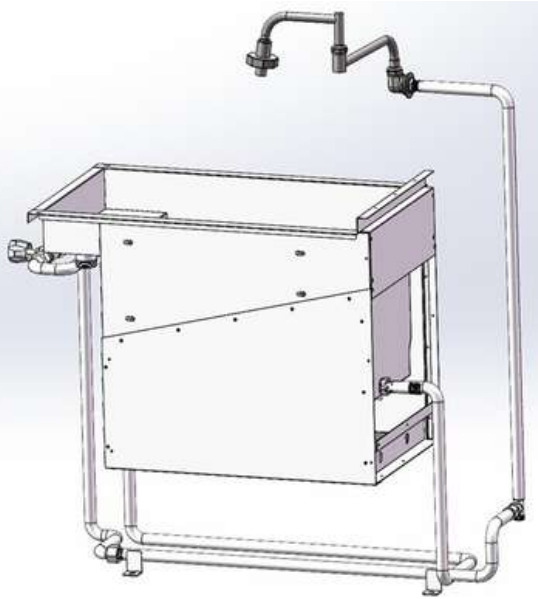

**The material of pot, shelf is type 316 stainless steel.**

**One M shape stainless steel burners, 60,000 BTU.**

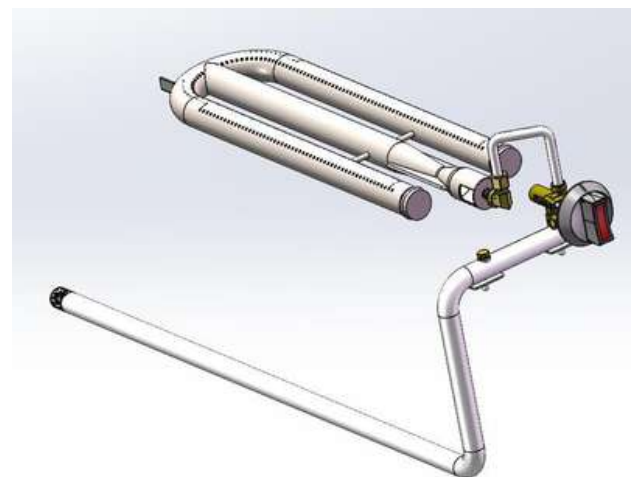
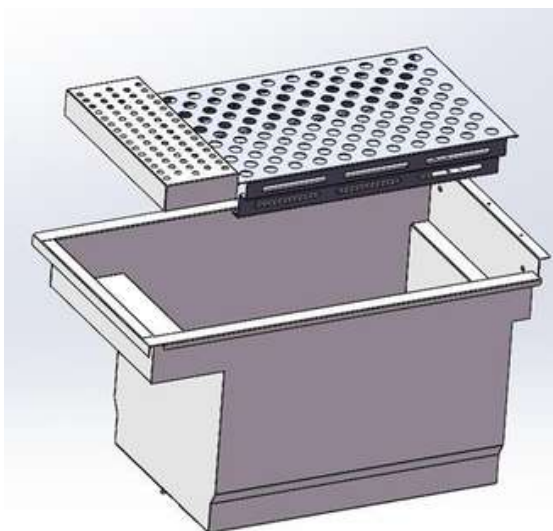



Toll free +1 (833) 978 8833  
sales@mckequipment.ca  
Visit [mckonline.ca](http://mckonline.ca) for more details

Quality Kitchen  
Equipment & Supplies



## Features

A tank with 6 baskets.

This floor model with 4 sturdy 6" adjustable legs for secure operation.

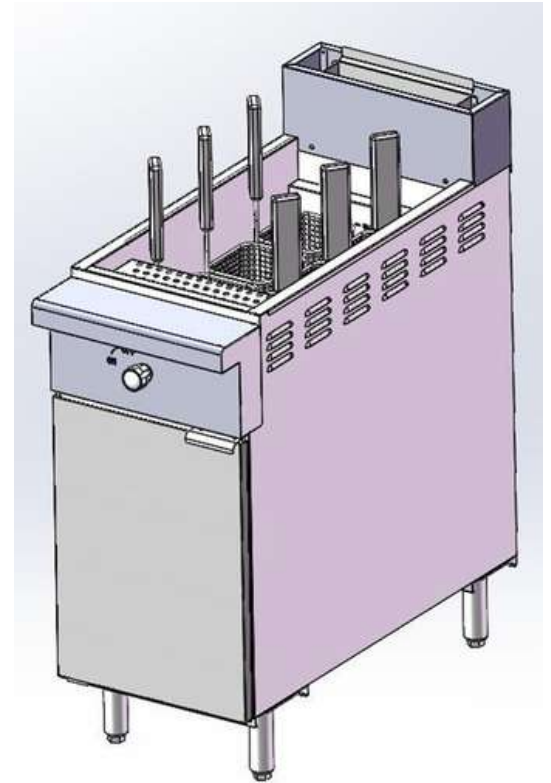
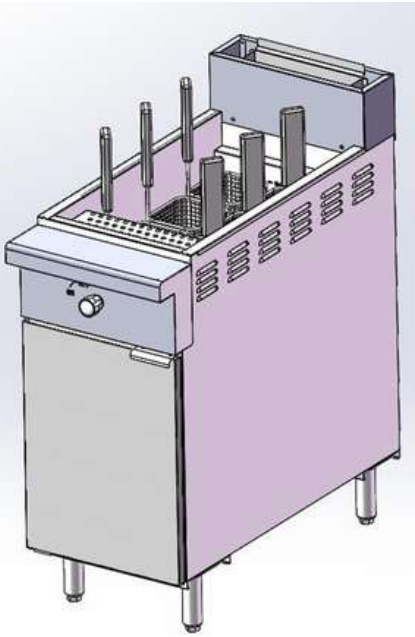



Toll free +1 (833) 978 8833  
 sales@mckequipment.ca  
 Visit [mckonline.ca](http://mckonline.ca) for more details

Quality Kitchen  
 Equipment & Supplies



# Electric Manual Toasters

**MCK-GD-TS2 | MCK-GD-TS4 | MCK-GD-TS6**



**MCK-GD-TS2**



**MCK-GD-TS4**



**MCK-GD-TS6**





## Features:

- Powerful heating element
- Manual ejector lever
- Anti-slip rubber feet

### SPECIFICATIONS

Model Number	Size (inches)	Net Weight (lbs)	Gross Weight (lbs)
<b>MCK-GD-TS2</b>	10.83 x 8.66 x 8.66	8.38	11.68
<b>MCK-GD-TS4</b>	12.40 x 10.83 x 8.66	10.58	13.89
<b>MCK-GD-TS6</b>	15.94 x 10.83 x 8.66	12.79	16.09



Toll free +1 (833) 978 8833  
 sales@mckequipment.ca  
 Visit [mckonline.ca](http://mckonline.ca) for more details

Quality Kitchen  
 Equipment & Supplies



# Electric Fryer

MCK-EF-11KW | MCK-EF-14KW

## FEATURES:

- **Construction:**

Welded tank with an extra smooth peened finish for easy cleaning

- **Heating Elements:**

Immersion type, sealed construction heating elements with a high temperature stainless steel sheath

- **Safety Design:**

Fixed heating element design eliminates oil migration through pivot components, enhancing safety by keeping hot elements securely within the tank

- **Exterior:**

Stainless steel front, door, sides, and splashback for durability and a clean professional appearance



MCK-EF-11KW | MCK-EF-14KW





### SPECIFICATIONS

Model	Voltage	Phase	Electrical rating	Oil capacity	Temperature range
MCK-EF-11KW	240V	1ph/3ph	14KW	23L	200-400F
MCK-EF-14KW	208V	1ph/3ph	11 KW	23L	200-400F

### PLAN VIEW

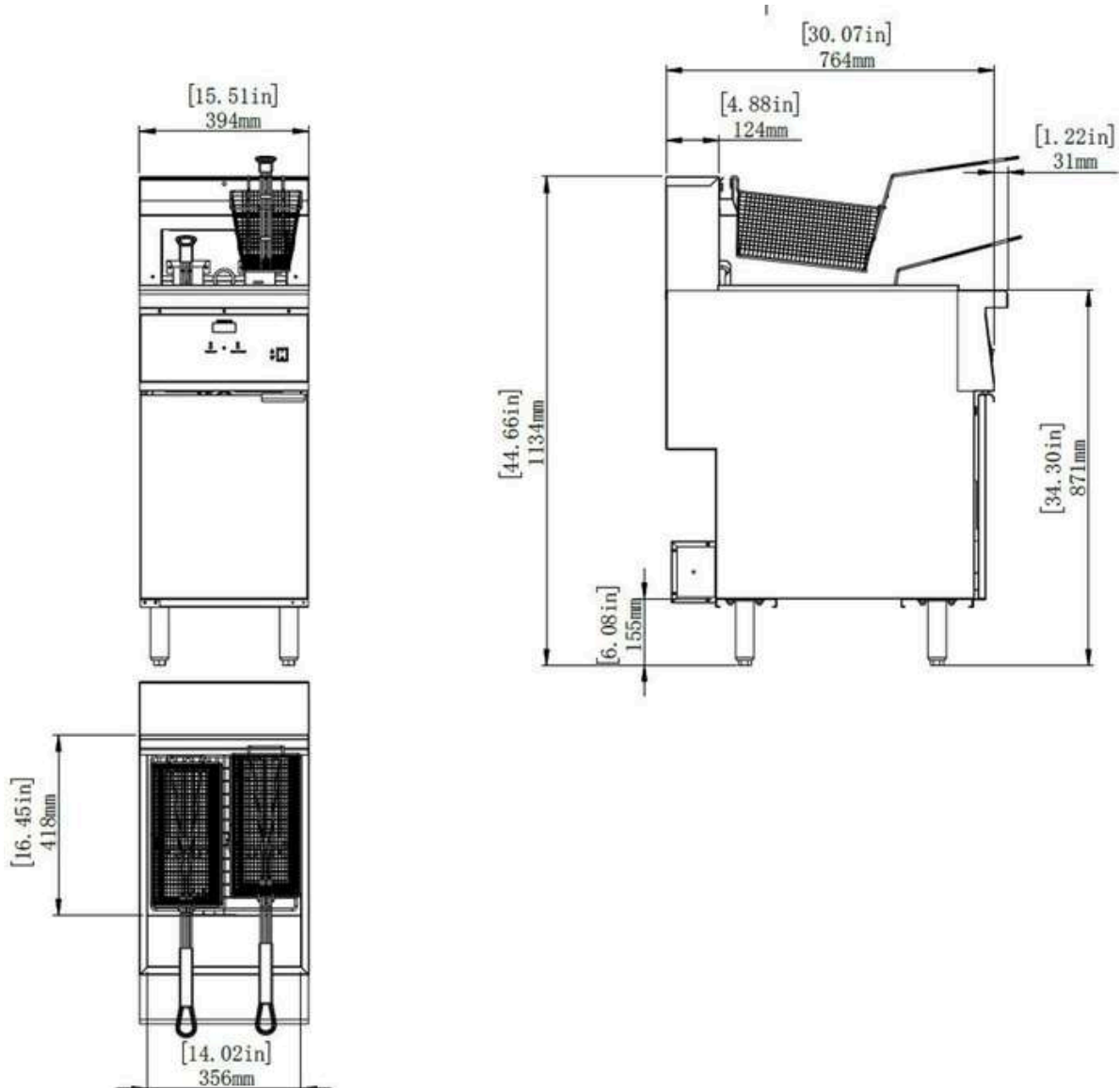



## Detailed Configuration

Two sets of heating elements, 7KW per set, total 14KW. The heat element is fast and easy to clean

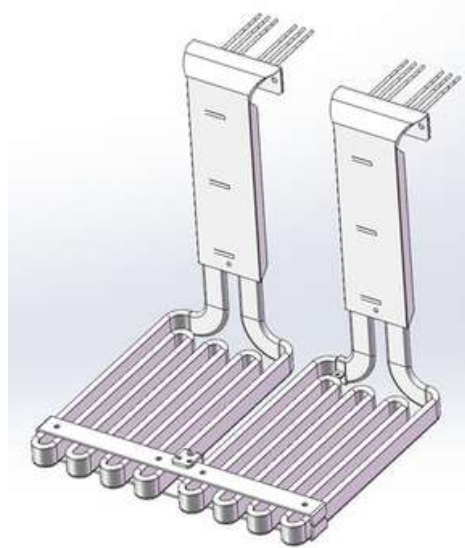

Liftable heat elements ,which makes it easy for cleaning

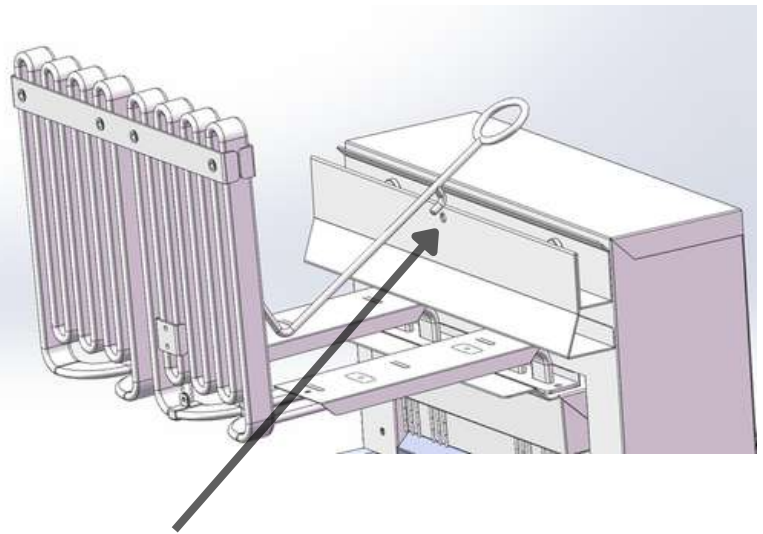
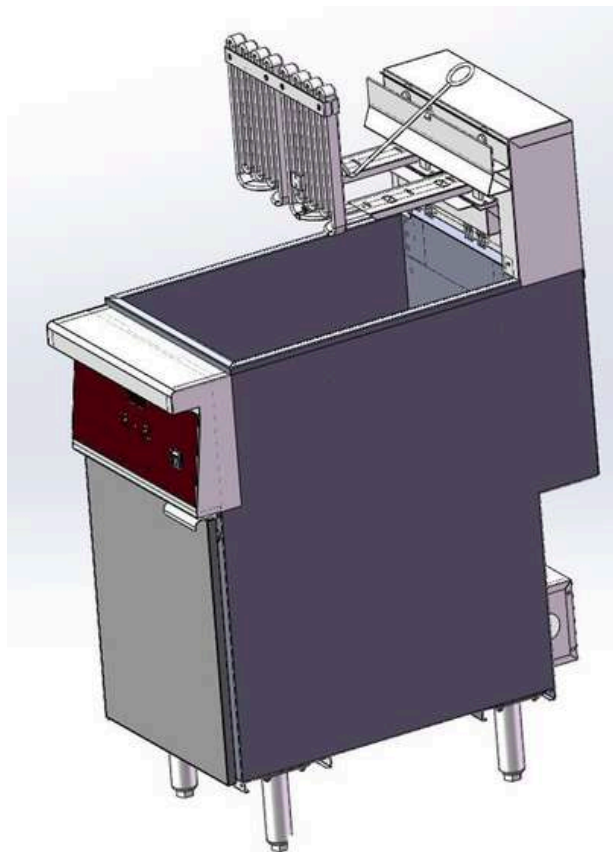

The rod stops the heat tube at this position



The electrical box is located at the back of the fryer. Open the box to connect the cable to the fryer.

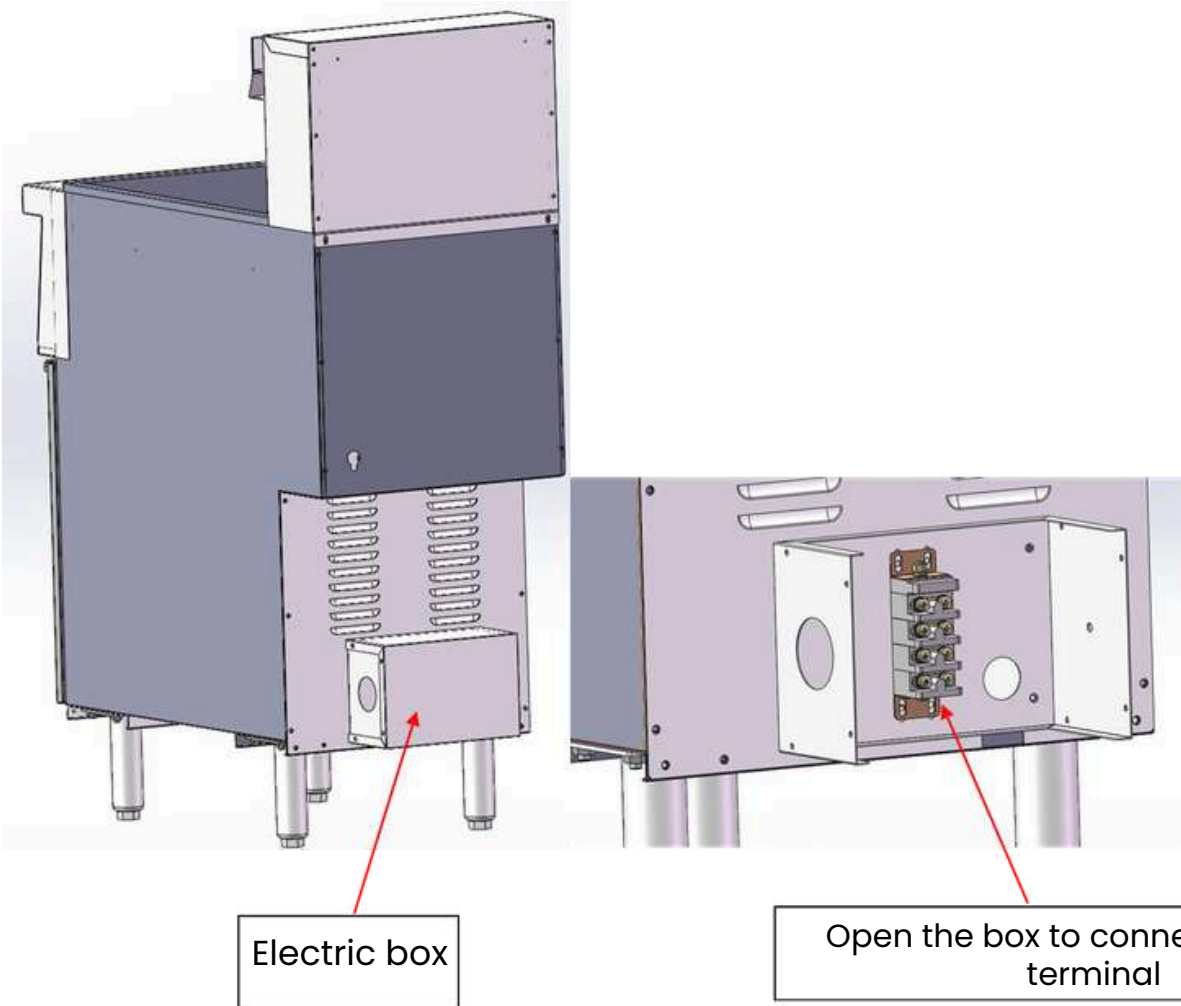



The control panel is located at the front of the fryer. The temperature is digitally displayed, making it easy to access and convenient to operate.

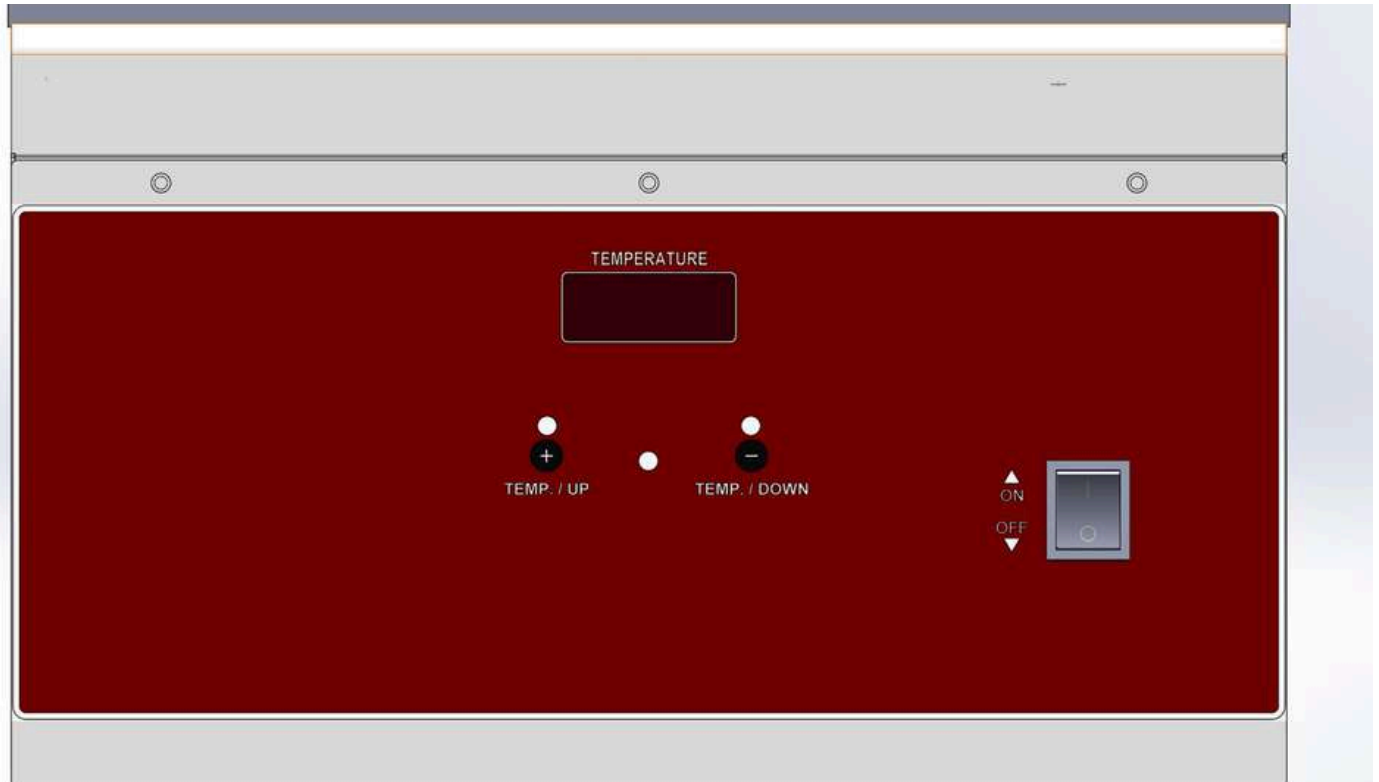

Temperature rising test:

temperature No	Date	Time	continuous test time (S)	back cover	cable	top ledge	electric box cover	front panel	contactor	thermostatic board	side panel	room temperature	handle of drain oil valve	switch power	ON/OFF	Hi-limit	relay
2669	2024/5/27	11:55:40	8007	46	28.6	40.4	34.2	47.2	32.1	57.1	81.1	25.6	44.3	32.1	48.5	31.9	32.2
2670	2024/5/27	11:55:43	8010	45.9	28.6	40.5	34.2	47.3	32.1	57.1	81.2	25.7	44.4	32.1	48.5	31.9	32.3
		maximum		46	28.8	40.5	34.3	47.3	32.1	57.6	81.2	25.9	44.8	32.6	48.5	32.1	32.9

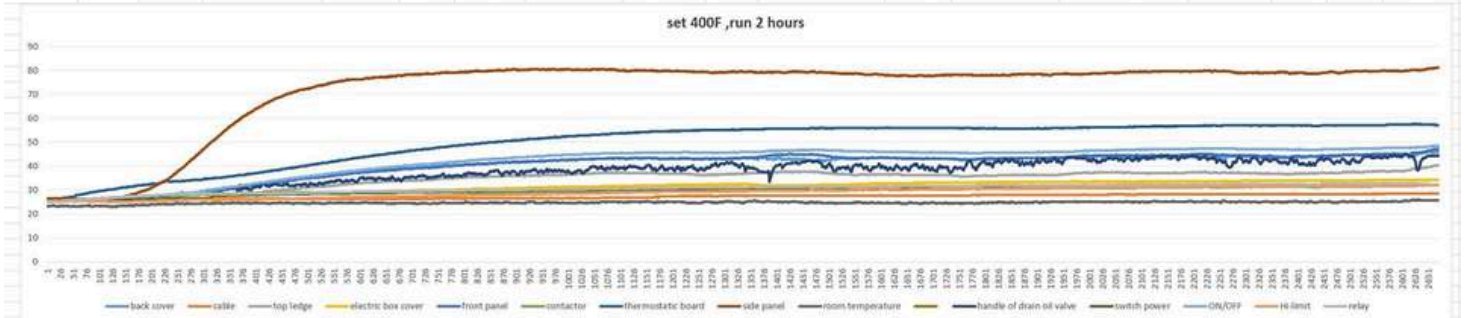



Toll free +1 (833) 978 8833  
 sales@mckequipment.ca  
 Visit [mckonline.ca](http://mckonline.ca) for more details



## Test to determine the time required for the temperature to rise again

### ◆ Temperature Rise-Up Test Data

Pot	Frying Time (s)	Set Oil Temperature (°F)	Lowest Temp During Test (°F)	Time to Rise to 340°F (s)	Test Date
1	160	350	311	26	2024.05.28
2	155	350	325	1	2024.05.28
3	155	350	321	0	2024.05.28

### ◆ Summary Data

Specification	Value
Model	HFEF-14KW
Power	14473W / 60.3A / 240V
Time for Water to Boil (from room temperature 25.5°C)	591 seconds
Time to Heat Oil from Room Temperature to 350°F	540 seconds

# **Beverage Dispencers**

Juice Dispencer

Slush Dispencer

Coffee Urn



Toll free +1 (833) 978 8833  
 sales@mckequipment.ca  
 Visit [mckonline.ca](http://mckonline.ca) for more details

Quality Kitchen  
 Equipment & Supplies



# Juice Dispenser

## MCK-GD-JD9X2

### Features:

- The main body is crafted from high grade stainless steel for a sleek look, easy cleaning, and long lasting durability
- Equipped with a high-quality compressor for consistent and dependable function
- Designed to be energy-saving and environmentally friendly



**MCK-GD-JD9X2**

### SPECIFICATIONS

Model Number	Size (inches)	Net Weight (lbs)	Gross Weight (lbs)
MCK-GD-JD9X2	12.99 × 15.35 × 26.38	46.30	50.71





Toll free +1 (833) 978 8833  
 sales@mckequipment.ca  
 Visit [mckonline.ca](http://mckonline.ca) for more details

Quality Kitchen  
 Equipment & Supplies



# Slush Machine

## MCK-GD-SL12X2

### Features:

- The main body is crafted from high grade stainless steel for a sleek look, easy cleaning, and long lasting durability..
- Equipped with a high-quality compressor for consistent and dependable function.
- Designed to be energy-saving and environmentally friendly.



**MCK-GD-SL12X2**

### SPECIFICATIONS

Model Number	Size (inches)	Net Weight (lbs)	Gross Weight (lbs)
<b>MCK-GD-SL12X2</b>	16.93 x 20.08 x 30.1	97	121





Toll free +1 (833) 978 8833  
 sales@mckequipment.ca  
 Visit [mckonline.ca](http://mckonline.ca) for more details

Quality Kitchen  
 Equipment & Supplies



# Coffee Urn

**HLB050S-A2K | HLB680S-A2K |  
 HLB088S-A2K | HLB100S-A2K |  
 HLB150S-A2K | HLB180S-A2K |  
 HLB220S-A2K**

## Description:

- Optimized thermal retention design
- Sturdy & Sanitary Construction  
 Crafted from premium 304 grade stainless steel delivering exceptional rust resistance, long term reliability and effortless maintenance.
- Heat defying handle that ensures slip resistant control, maintains ambient temperature and eliminates burning risks during operation.
- The stepped design ensures complete drainage of liquid, preventing residual water or coffee from pooling at the bottom.





**SPECIFICATIONS**

<b>Model Number</b>	<b>Size (inches)</b>	<b>Net Weight (lbs)</b>	<b>Gross Weight (lbs)</b>	<b>Capacity (Cups)</b>
<b>HLB050S-A2K</b>	DIA:9.06 x H:16.54	6.61	7.94	21
<b>HLB680S-A2K</b>	DIA:9.06 in x H:17.20	7.05	8.38	23
<b>HLB088S-A2K</b>	DIA:9.06 in x H:18.58	7.05	7.94	28
<b>HLB100S-A2K</b>	DIA:9.06 in x H:19.84	7.72	9.04	32
<b>HLB150S-A2K</b>	DIA:11.42 in x H:19.09	9.48	11.68	48
<b>HLB180S-A2K</b>	DIA:11.42 in x H:20.35	9.92	12.13	57
<b>HLB220S-A2K</b>	DIA:11.42 in x H:22.87	11.02	13.23	73



Toll free +1 (833) 978 8833  
info@mckequipment.ca  
Visit [mckonline.ca](http://mckonline.ca) for more details



# OVENS

Pizza Oven | Electric |  
Single Chamber

Convection Oven | Electric | Single  
and Double Chamber



Toll free +1 (833) 978 8833  
 info@mckequipment.ca  
 Visit [mckonline.ca](http://mckonline.ca) for more details



# Single Chamber Electric Pizza Oven

EZP-9

## FEATURES

- Italian Engineering, Made with Precision
- Premium Italian Refractory Stone (Unistara) – High-quality stone imported from Italy.
- Breathable Stone Surface for Perfect Pizza Crusts – The textured surface of the refractory stone allows air circulation beneath the dough, preventing burning and ensuring a crisp, golden crust.
- Durable Stainless Steel Construction
- Superior Heat Insulation for Energy Efficiency
- Versatile Control Options – Choose between mechanical or digital controllers, offering precision and flexibility for different baking needs.
- Heavy-Duty Spring-Loaded Door Hinge – Smooth and easy opening & closing mechanism enhances usability, improving kitchen workflow.
- Multi-Purpose Baking Performance
- Even Heating with Optimized Element Placement
- Industry Benchmark in Performance



Digital Control Knob



Digital Control Panel



Mechanical Control





Toll free +1 (833) 978 8833  
 info@mckequipment.ca  
 Visit [mckonline.ca](http://mckonline.ca) for more details

Quality Kitchen  
 Equipment & Supplies



## SPECIFICATIONS

Model	Chamber	V/Hz	Power	Temp. ©	Stone Qty.	Italian Stone Size/mm	Ø 30/34 cm Qty	Ø 50 cm Qty	Size (DxWxH) mm	Packing Size (DxWxH) mm	Net Weight (kg)	Gross Weight (kg)
EZP-9	Single Chamber	220/60/3PH	4.7 kW	Max. 450 C	3	1050 x 350	9	4	1450 x 1185 x 405	1490 x 1290 x 540	175	190

Input current 35A

## PLAN VIEW

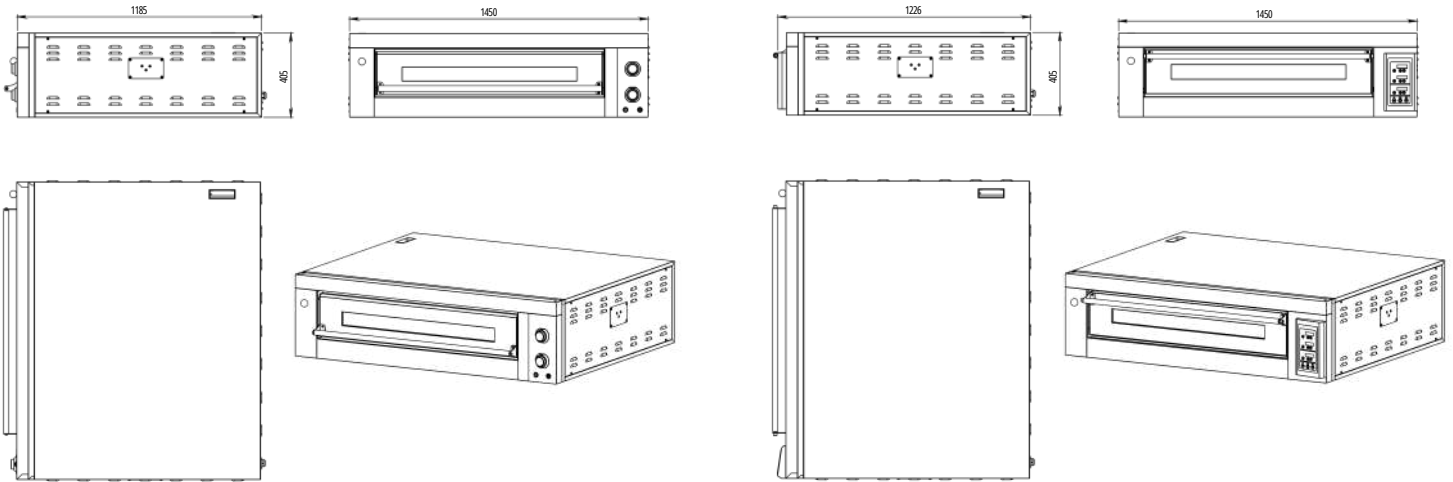

Digital Control Knob

Digital Control Panel

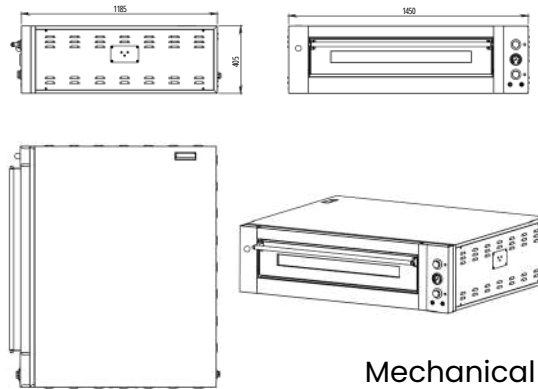

Mechanical Control

Digital Control Knob

Digital Control Panel

Mechanical Control

Wide Space





Toll free +1 (833) 978 8833  
sales@mckequipment.ca  
Visit [mckonline.ca](http://mckonline.ca) for more details

Quality Kitchen  
Equipment & Supplies



# Electric Convection Oven

## FEATURES:

- 29" (Width) x 21.5" (Depth) x 20" (Height)
- Temperature range: 150°F to 500°F
- 1/2 HP two speed fan motor (High: 1710 RPM, Low: 1120 RPM)
- Porcelain enamel lining, seamless interior & corners for easy cleaning
- 10 position guide rack with 1.5" spacing
- 5 heavy duty adjustable chrome-plated racks
- Trapezoidal leg with casters.



**MCK-ECO-9KW**





Toll free +1 (833) 978 8833  
 sales@mckequipment.ca  
 Visit [mckonline.ca](http://mckonline.ca) for more details

Quality Kitchen  
 Equipment & Supplies



# Double Electric Convection Oven

**MCK-ECO-9KW-D**



MCK Equipment  
 mckonline.ca

**Please be informed:** Product specifications or design are subject to change without notice. Notify any special requirement to your sales representative.

**327**





## Construction:

- Top and front constructed with stainless steel for durability and hygiene
- Double pane thermal 5mm thickness glass windows on the doors
- Doors are equipped with an interlock switch that automatically turns the fan and heaters off when opened

## SPECIFICATIONS

Model	Racks	External Dimensions(in)			Internal Oven Dimensions			Total Power (KW)	Volts	Phases
		W	D	H	W	D	H			
MCK-ECO-9KW	5	38	40.6	54	29	21.5	20	9	208	1or 3
MCK-ECO-9KW-D	5	38	40.6	54	29	21.5	20	9	208	1or 3
MCK-ECO-11KW	5	38	40.6	54	29	21.5	20	11	240	1or 3
MCK-ECO-9KW-D	5	38	40.6	54	29	21.5	20	11	240	1or 3



PLAN VIEW

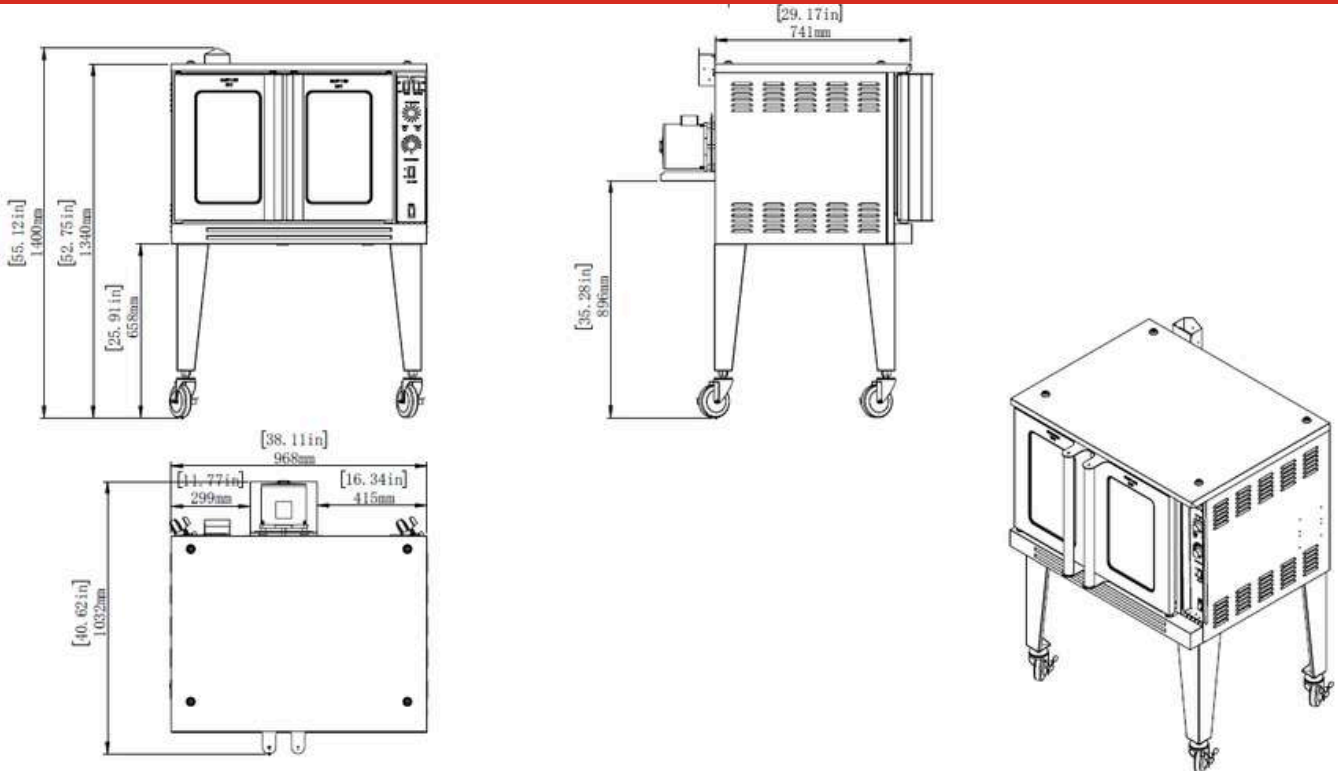

Detailed Structure

Optimized smoke/flue gas routing ensures uniform temperature distribution throughout the chamber.

A three way heat circulation system directs smoke along the sides and rear, pulling it into the cooking chamber through two rear suction ports. This design uses a powerful combination of direct heat and radiant heat from four heated surfaces to guarantee superior and uniform cooking results.

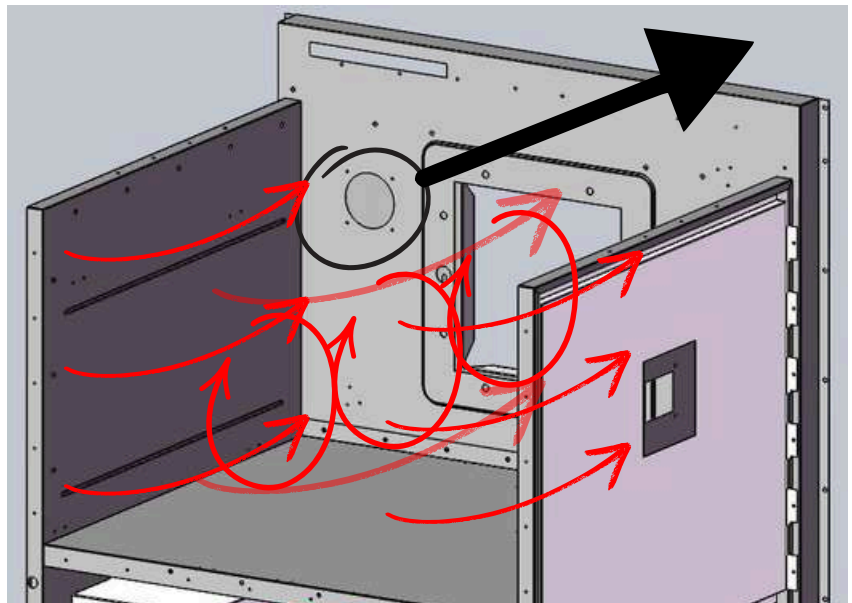



Toll free +1 (833) 978 8833  
sales@mckequipment.ca  
Visit [mckonline.ca](http://mckonline.ca) for more details



# **FURNITURE**

Restaurant Seating  
Restaurant Tables  
Special Furniture



Toll free +1 (833) 978 8833  
 sales@mckequipment.ca  
 Visit [mckonline.ca](http://mckonline.ca) for more details

Quality Kitchen  
 Equipment & Supplies



# Dining Metal Chairs (Ladder)

FUR-T145

## FEATURES

- Versatile Design: Classic look suitable for modern or traditional venues.
- Back Style Options: Available in Cross and Ladder back designs.
- Durable Construction: Strong 16 gauge steel frame with fully welded stress joints.
- Solid wood seat with commercial grade foam.
- Padded seats in vinyl, wood seats and leather finish.



FUR-T145

## SPECIFICATIONS

Model	Height (Inch)	Color	Tube Size	Thickness (mm)	Seat Material	Frame Material	Back design	Weight Capacity (lbs)	Net Weight (lbs)	Dimension (Inch)	Gross Weight (lbs)
FUR-T145	19	Black	30 x 30	1.1	Playwood / PVC / Vinyl	Metal	Ladder	500	14.55	32 x 17 x 19	15.43

## PLAN VIEW

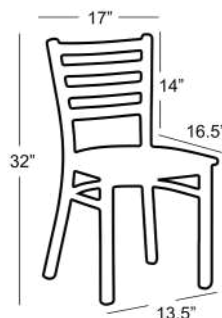



Toll free +1 (833) 978 8833  
 sales@mckequipment.ca  
 Visit [mckonline.ca](http://mckonline.ca) for more details

Quality Kitchen  
 Equipment & Supplies



# Dining Metal Chairs (Cross)

FUR-T159

## FEATURES

- Versatile Design: Classic look suitable for modern or traditional venues.
- Back Style Options: Available in Cross and Ladder back designs.
- Durable Construction: Strong 16 gauge steel frame with fully welded stress joints.
- Solid wood seat with commercial grade foam.
- Padded seats in vinyl, wood seats and leather finish.



FUR-T159

## SPECIFICATIONS

Model	Height (Inch)	Color	Tube Size	Thickness (mm)	Seat Material	Frame Material	Back design	Weight Capacity (lbs)	Net Weight (lbs)	Dimension (Inch)	Gross Weight (lbs)
FUR-T159	19	Black	30 x 30	1.1	Playwood / PVC / Vinyl	Metal	Cross	500	14.55	32 x 17 x 19	15.43

## PLAN VIEW

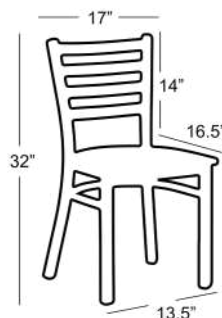



Toll free +1 (833) 978 8833  
 sales@mckequipment.ca  
 Visit [mckonline.ca](http://mckonline.ca) for more details

Quality Kitchen  
 Equipment & Supplies



# Bar Height Metal Ladder Back Chair (Ladder)

FUR-T145B

## FEATURES

- Bar-height design perfect for counters and high tables with elegant natural wood finish for a classic look
- Durable metal construction ensures long-lasting use
- Ladder back provides ergonomic support and comfort
- Smooth surfaces and simple design make maintenance a breeze
- Combines rustic wood with modern metal for a timeless look
- Designed to withstand heavy use in commercial settings. Fits well in various dining and bar setups.



FUR-T145B

## SPECIFICATIONS

Model	Frame Color	Frame Material	Seat Material	Weight Capacity (lbs)	Dimension (DWH Inch)	Net Weight (lbs)
FUR-T145B	Black	Metal	Black PVC	330	17 x 17 x 42	20.4
FUR-T157-5B			Wood			

## COLOR



## PLAN VIEW

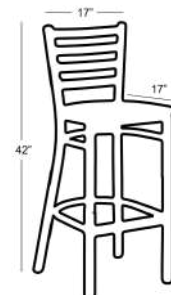



Toll free +1 (833) 978 8833  
 sales@mckequipment.ca  
 Visit [mckonline.ca](http://mckonline.ca) for more details

Quality Kitchen  
 Equipment & Supplies



# Bar Height Metal Ladder Back Chair (Cross)

FUR-T159B

## FEATURES



FUR-T159B

## SPECIFICATIONS

Model	Frame Color	Frame Material	Seat Material	Weight Capacity (lbs)	Dimension (DWH Inch)	Net Weight (lbs)
FUR-T159B	Black	Metal	Leather	330	17 x 17 x 42	20.4
FUR-T187B			Black PVC			
FUR-T230B			Wood			

## PLAN VIEW

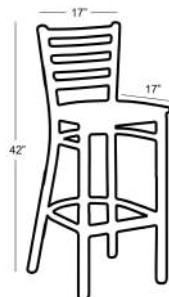



Toll free +1 (833) 978 8833  
 sales@mckequipment.ca  
 Visit [mckonline.ca](http://mckonline.ca) for more details

Quality Kitchen  
 Equipment & Supplies



# Commercial Wooden High Chair

MCK-ROY-702M

## FEATURES

- Built to withstand rigorous daily use in restaurants and cafes
- Attractive and durable natural wood construction
- Includes a safety strap to secure children safely. High back and wide seat for added comfort and support.
- Designed for stability and easy storage. Smooth surface allows for quick and easy cleaning.
- Timeless design that complements any decor.



MCK-ROY-702M

## SPECIFICATIONS

Model	Frame Color	Frame Material	Seat Material	Weight Capacity (lbs)	Dimension (DWH Inch)	Net Weight (lbs)	Gross Weight (lbs)
MCK-ROY-702M MCK-ROY-702N	Natural, Walnut, Mahogany	Wood	Wood	-	20 x 20 x 29	13	15

## COLOR



## PLAN VIEW

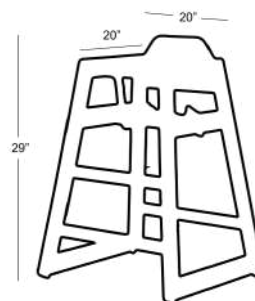



# Table Tops

## FEATURES

- Reversible laminated table tops
- Solid black molding to prevent chipping and scuffing



## SPECIFICATIONS

Model	Shape	Material	Color / Finishing	Dimensions (WDH Inch)	
FUR-TT2424	Square	Laminated / Rubber Seal	Black	24 x 24 x 1	
FUR-TT2430MB	Rectangular		Mahogany / Black	24 x 30 x 1	
FUR-TT3060BM				30 x 60 x 1	
FUR-TT30BM	30 x 1				
FUR-TT36MB	Round			36 x 1	
FUR-TT48BM				48 x 1	
FUR-TT60BM				60 x 1	
FUR-TTL2424OW				Square	24 x 24 x 1
FUR-TTL2430OW	Rectangular			24 x 30 x 1	
FUR-TTL24ROW	Round			Dark Walnut	24 x 1.5
FUR-TTL3030MB	Square			Mahogany / Black	30 x 30 x 1.5
FUR-TTL3030OW			Dark Walnut	30 x 30 x 1.5	
FUR-TTL3042MB	Rectangular		Black	30 x 42 x 1.5	
FUR-TTL3048BM			Mahogany / Black	30 x 46 x 1.5	
FUR-138G2152430			Tan Brown Granite	-	24 x 30
FUR-3492424CLN30			Antique Natural Finish	Brown	24 x 24
FUR-427SD2848MP			Mixed Plank	-	24 1/2 x 47 3/16
FUR-427SM2848VE	Versilla Finish		-	24 1/2 x 47 3/16	
FUR-SW24	Round		Solid Wood	Cherry	24 x 30 x 1.5
FUR-SW3048					30 x 48 x 1.5
FUR-SW30R		30 x 1			
FUR-SW36R		Mahogany / Black		36 x 1	
FUR-SW48-LUQ		Rectangular		Brown	48 x 30 x 1

## COLORS AND MORE DETAILS





Toll free +1 (833) 978 8833  
sales@mckequipment.ca  
Visit mckonline.ca for more details



# **WARRANTY & OTHER POLICIES**



## REFRIGERATION, CHEST FREEZERS, COUNTERTOP EQUIPMENT & ICE MACHINES

### 2 Year Parts & Labour – 5 Year Compressor

#### General Warranty Coverage:

- **1 Year Parts & Labour:** MCK Equipment warrants all refrigeration equipment and ice machines against defects in materials and workmanship for a period of one (1) year from the date of shipment. This coverage includes both parts and labor costs necessary to repair or replace any defective component.
- **5 Year Compressor Warranty:** The compressor, a critical component of your refrigeration equipment or ice machine, is warranted for a period of five (5) years from the date of shipment. This warranty covers the cost of the compressor part only. Labor charges related to the replacement of the compressor after the first year are not covered.

#### Compressor Warranty

The five-year compressor warranty detailed above will be void if the following procedure is not carefully adhered to:

1. This system contains R404A, R134a, or R290 refrigerant and lubricant.  
The lubricant has rapid moisture absorbing qualities.
2. Drier replacement is very important and must be changed when a system is opened for servicing.
3. Micron level vacuums must be achieved to insure low moisture levels in the system.
4. Compressor must be obtained through MCK Equipment, unless otherwise specified in writing.

#### Warranty Claim Process:

All claims for parts or labor must be made directly through MCK Equipment. To process a warranty claim, the following information must be provided:

1. Model number of the unit.
2. Serial number of the unit.
3. Proof of purchase.

For compressor claims, the defective compressor or compressor tag must be returned to MCK Equipment along with the above information. Failure to comply with these warranty policies will result in the voiding of any claims.

#### How to Get Warranty Service:

For warranty service, technical support, or to purchase replacement parts, please contact MCK Equipment directly. Our team is here to assist you with both warranty and non-warranty related questions or issues.



Toll free +1 (833) 978 8833  
sales@mckequipment.ca  
Visit [mckonline.ca](http://mckonline.ca) for more details

Quality Kitchen  
Equipment & Supplies



**ROUTINE MAINTENANCE OBLIGATIONS:** Adherence to routine maintenance as specified in the owner's manual is essential. Failure to follow these requirements will void the warranty.

**LIMITATION OF LIABILITY:** MCK Equipment is not liable for economic losses, loss of profits, or any special, exemplary, punitive, indirect, or consequential damages, including but not limited to, losses arising from food or product spoilage, regardless of whether they result from equipment failure.

**WARRANTY EXCLUSIONS:** The warranty does not cover any parts that have been subjected to alteration, neglect, abuse, misuse, accident, damage during transit or installation, fire, flood, or acts of God after the date of manufacture.

**ELECTRICAL CONNECTION RESPONSIBILITY:** MCK Equipment is not responsible for the repair or replacement of components that fail or are damaged due to electrical power failures, the use of extension cords, low voltage, or voltage drops affecting the unit.

**WARRANTY DISCLAIMER:** The one (1) year parts & labor warranty and the additional five (5) year compressor warranty are exclusive and in lieu of all other warranties. MCK Equipment disclaims any implied warranty of merchantability or fitness for a particular purpose, as well as any implied warranties of non-infringement. There are no warranties extending beyond the terms outlined here.

**INTERNATIONAL WARRANTY EXCLUSIONS:** This warranty does not apply to products sold or used outside the continental United States and Canada. MCK Equipment is not responsible for any warranty claims made on products used in these areas.

**RETURN POLICY:** For every return request, a restocking fee will be issued. This covers the costs of restocking the returned equipment. This will be deducted from the return amount due. The restocking fee for commercial locations is 20% of the equipment cost while that of residential locations is 30% of the equipment cost.

#### What is Not Covered by This Warranty:

1. Routine maintenance tasks required to keep the equipment in proper working order.
2. Consequential damages resulting from the use or failure of the equipment.
3. Damage due to alteration, neglect, abuse, misuse, accident, improper installation, or acts of God (such as fire, flood, etc.).
4. Repairs necessitated by improper electrical connections.
5. Warranty is not transferable and only applies to the original buyer.

The warranties described above are exclusive and in lieu of all other warranties. MCK Equipment disclaims any implied warranty of merchantability or fitness for a particular purpose. There are no warranties which extend beyond the description provided herein.

**For any additional inquiries regarding your warranty or to submit a claim, please contact MCK Equipment at +1 (833) 978 8833 or, at [claims@mckequipment.ca](mailto:claims@mckequipment.ca)**



## COOKING & HOLDING EQUIPMENT

### 1 Year Parts & Labour

#### General Warranty Coverage:

- **1 Year Parts & Labour:** MCK Equipment warrants all Cooking & Holding Equipment against defects in materials and workmanship for a period of one (1) year from the date of shipment. This coverage includes both parts and labor costs necessary to repair or replace any defective component.

#### Warranty Claim Process:

All claims for parts or labor must be made directly through MCK Equipment. To process a warranty claim, the following information must be provided:

1. Model number of the unit.
2. Serial number of the unit.
3. Proof of purchase.

#### How to Get Warranty Service:

For warranty service, technical support, or to purchase replacement parts, please contact MCK Equipment directly. Our team is here to assist you with both warranty and non-warranty related questions or issues.

**ROUTINE MAINTENANCE OBLIGATIONS:** Adherence to routine maintenance as specified in the owner's manual is essential. Failure to follow these requirements will void the warranty.

**LIMITATION OF LIABILITY:** MCK Equipment is not liable for economic losses, loss of profits, or any special, exemplary, punitive, indirect, or consequential damages, including but not limited to, losses arising from food or product spoilage, regardless of whether they result from equipment failure.

**WARRANTY EXCLUSIONS:** The warranty does not cover any parts that have been subjected to alteration, neglect, abuse, misuse, accident, damage during transit or installation, fire, flood, or acts of God after the date of manufacture.

**ELECTRICAL CONNECTION RESPONSIBILITY:** MCK Equipment is not responsible for the repair or replacement of components that fail or are damaged due to electrical power failures, the use of extension cords, low voltage, or voltage drops affecting the unit.

**WARRANTY DISCLAIMER:** The one (1) year parts & labor warranty are exclusive and in lieu of all other warranties. MCK Equipment disclaims any implied warranty of merchantability or fitness for a particular purpose, as well as any implied warranties of non-infringement. There are no warranties extending beyond the terms outlined here.



Toll free +1 (833) 978 8833  
sales@mckequipment.ca  
Visit [mckonline.ca](http://mckonline.ca) for more details

Quality Kitchen  
Equipment & Supplies



**INTERNATIONAL WARRANTY EXCLUSIONS:** This warranty does not apply to products sold or used outside the continental United States and Canada. MCK Equipment is not responsible for any warranty claims made on products used in these areas.

**RETURN POLICY:** For every return request, a restocking fee will be issued. This covers the costs of restocking the returned equipment. This will be deducted from the return amount due. The restocking fee for commercial locations is 20% of the equipment cost while that of residential locations is 30% of the equipment cost.

#### **What is Not Covered by This Warranty:**

1. Routine maintenance tasks required to keep the equipment in proper working order.
2. Consequential damages resulting from the use or failure of the equipment.
3. Damage due to alteration, neglect, abuse, misuse, accident, improper installation, or acts of God (such as fire, flood, etc.).
4. Repairs necessitated by improper electrical connections.
5. Warranty is not transferable and only applies to the original buyer.

The warranties described above are exclusive and in lieu of all other warranties. MCK Equipment disclaims any implied warranty of merchantability or fitness for a particular purpose. There are no warranties which extend beyond the description provided herein.

**For any additional inquiries regarding your warranty or to submit a claim, please contact MCK Equipment at +1 (833) 978 8833 or, at [claims@mckequipment.ca](mailto:claims@mckequipment.ca)**



## MIXERS, SLICERS AND MEAT GRINDERS

### 1 Year Parts & Labour

#### General Warranty Coverage:

MCK Equipment warrants all new mixers, slicers, and meat grinders to be free from defects in materials or workmanship. MCK Equipment's obligation under this warranty is limited to a period of one (1) year from the date of shipment from MCK Equipment. All parts covered under this warranty that are defective within one (1) year from the date of shipment from MCK Equipment are limited to repair or replacement (including labor charges) of defective parts or assemblies. The labor warranty shall include standard straight time labor charges only and reasonable travel time, as determined by MCK Equipment.

#### Warranty Claim Process:

All claims for parts or labor must be made directly through MCK Equipment. To process a warranty claim, the following information must be provided:

1. Model number of the unit.
2. Serial number of the unit.
3. Proof of purchase.

#### How to Get Warranty Service:

For warranty service, technical support, or to purchase replacement parts, please contact MCK Equipment directly. Our team is here to assist you with both warranty and non-warranty related questions or issues.

**ROUTINE MAINTENANCE OBLIGATIONS:** Adherence to routine maintenance as specified in the owner's manual is essential. Failure to follow these requirements will void the warranty.

**LIMITATION OF LIABILITY:** MCK Equipment is not liable for economic losses, loss of profits, or any special, exemplary, punitive, indirect, or consequential damages, including but not limited to, losses arising from food or product spoilage, regardless of whether they result from equipment failure.

**WARRANTY EXCLUSIONS:** The warranty does not cover any parts that have been subjected to alteration, neglect, abuse, misuse, accident, damage during transit or installation, fire, flood, or acts of God after the date of manufacture.

**ELECTRICAL CONNECTION RESPONSIBILITY:** MCK Equipment is not responsible for the repair or replacement of components that fail or are damaged due to electrical power failures, the use of extension cords, low voltage, or voltage drops affecting the unit.

**WARRANTY DISCLAIMER:** The one (1) year parts & labor warranty are exclusive and in lieu of all other warranties. MCK Equipment disclaims any implied warranty of merchantability or fitness for a



Toll free +1 (833) 978 8833  
sales@mckequipment.ca  
Visit [mckonline.ca](http://mckonline.ca) for more details

Quality Kitchen  
Equipment & Supplies



particular purpose, as well as any implied warranties of non-infringement. There are no warranties extending beyond the terms outlined here.

**INTERNATIONAL WARRANTY EXCLUSIONS:** This warranty does not apply to products sold or used outside the continental United States and Canada. MCK Equipment is not responsible for any warranty claims made on products used in these areas.

**RETURN POLICY:** For every return request, a restocking fee will be issued. This covers the costs of restocking the returned equipment. This will be deducted from the return amount due. The restocking fee for commercial locations is 20% of the equipment cost while that of residential locations is 30% of the equipment cost.

#### **What is Not Covered by This Warranty:**

1. Routine maintenance tasks required to keep the equipment in proper working order.
2. Consequential damages resulting from the use or failure of the equipment.
3. Damage due to alteration, neglect, abuse, misuse, accident, improper installation, or acts of God (such as fire, flood, etc.).
4. Repairs necessitated by improper electrical connections.
5. Warranty is not transferable and only applies to the original buyer.

The warranties described above are exclusive and in lieu of all other warranties. MCK Equipment disclaims any implied warranty of merchantability or fitness for a particular purpose. There are no warranties which extend beyond the description provided herein.

**For any additional inquiries regarding your warranty or to submit a claim, please contact MCK Equipment at +1 (833) 978 8833 or, at [claims@mckequipment.ca](mailto:claims@mckequipment.ca)**



## STAINLESS STEEL FABRICATION EQUIPMENT

### 90 Day Limited Warranty

#### General Warranty Coverage:

All warranty claims must be made directly to MCK Equipment. All claims must include: model number of the unit, serial number, proof of purchase, date of installation, and all pertinent information supporting the alleged defect. Failure to comply with warranty policies will result in voiding claims.

#### 90 Day Warranty

MCK Equipment warrants all new stainless steel fabrication equipment against defects in materials and workmanship, subject to the following conditions:

- MCK Equipment obligation under this warranty is limited to a period of three (3) months from the date of shipment from MCK Equipment. This warranty applies to the original owner only, and is non transferable.
- Should any product fail to function in its intended manner under normal use within the limits defined in this warranty, at MCK Equipment discretion, such product will be replaced with a new unit by MCK Equipment, after defective unit has been inspected and defect has been confirmed. MCK Equipment does not assume any liability for extended delays in replacing any item beyond its control. This warranty does not apply to plastic and non-metallic synthetic parts that may need to be replaced due to normal usage, or lack of preventative maintenance.

#### Warranty Claim Process:

All claims for parts or labor must be made directly through MCK Equipment. To process a warranty claim, the following information must be provided:

1. Model number of the unit.
2. Serial number of the unit.
3. Proof of purchase.

**How to Get Warranty Service:** For warranty service, technical support, or to purchase replacement parts, please contact MCK Equipment directly. Our team is here to assist you with both warranty and non-warranty related questions or issues.

**ROUTINE MAINTENANCE OBLIGATIONS:** Adherence to routine maintenance as specified in the owner's manual is essential. Failure to follow these requirements will void the warranty.

**LIMITATION OF LIABILITY:** MCK Equipment is not liable for economic losses, loss of profits, or any special, exemplary, punitive, indirect, or consequential damages, including but not limited to, losses arising from food or product spoilage, regardless of whether they result from equipment failure.



Toll free +1 (833) 978 8833  
sales@mckequipment.ca  
Visit [mckonline.ca](http://mckonline.ca) for more details

Quality Kitchen  
Equipment & Supplies



**WARRANTY EXCLUSIONS:** The warranty does not cover any parts that have been subjected to alteration, neglect, abuse, misuse, accident, damage during transit or installation, fire, flood, or acts of God after the date of manufacture.

**ELECTRICAL CONNECTION RESPONSIBILITY:** MCK Equipment is not responsible for the repair or replacement of components that fail or are damaged due to electrical power failures, the use of extension cords, low voltage, or voltage drops affecting the unit.

**WARRANTY DISCLAIMER:** The one (1) year parts & labor warranty are exclusive and in lieu of all other warranties. MCK Equipment disclaims any implied warranty of merchantability or fitness for a particular purpose, as well as any implied warranties of non-infringement. There are no warranties extending beyond the terms outlined here.

**INTERNATIONAL WARRANTY EXCLUSIONS:** This warranty does not apply to products sold or used outside the continental United States and Canada. MCK Equipment is not responsible for any warranty claims made on products used in these areas.

**RETURN POLICY:** For every return request, a restocking fee will be issued. This covers the costs of restocking the returned equipment. This will be deducted from the return amount due. The restocking fee for commercial locations is 20% of the equipment cost while that of residential locations is 30% of the equipment cost.

#### **What is Not Covered by This Warranty:**

1. Equipment that has not been properly installed or maintained, damage from improper cleaning, and water damage to controls.
2. Equipment that has not been used in an appropriate manner, or has been subject to misuse, neglect, abuse, accident, alteration, negligence, damage during transit, fire, flood, or acts of God.

The warranties described above are exclusive and in lieu of all other warranties. MCK Equipment disclaims any implied warranty of merchantability or fitness for a particular purpose. There are no warranties which extend beyond the description provided herein.

**For any additional inquiries regarding your warranty or to submit a claim, please contact MCK Equipment at +1 (833) 978 8833 or, at [claims@mckequipment.ca](mailto:claims@mckequipment.ca)**



## KITCHEN HOODS

### Fast Kitchen Hoods Warranty Policy

#### 2-Year Parts Warranty

##### General Warranty Coverage:

Fast Kitchen Hoods warrants all kitchen hood equipment against defects in materials and workmanship for a period of two (2) years from the date of shipment. This warranty covers the replacement cost of any defective parts required to repair or maintain the unit during this period.

##### Warranty Claim Process:

All warranty claims must be made directly through Fast Kitchen Hoods. To process a warranty claim, the following information must be provided:

1. Model number of the unit.
2. Serial number of the unit.
3. Proof of purchase (invoice or receipt).

Fast Kitchen Hoods will not honor claims if any of the above information is missing or incomplete.

##### How to Get Warranty Service:

For warranty service, technical support, or to purchase replacement parts, please contact Fast Kitchen Hoods directly. Our team is available to assist with both warranty-related and non-warranty-related issues to ensure uninterrupted operation of your equipment.

**ROUTINE MAINTENANCE OBLIGATIONS:** Adherence to the routine maintenance requirements outlined in the owner's manual is essential. Failure to perform specified maintenance will void the warranty. This includes cleaning, filter replacement, and any other tasks outlined in the product documentation.

**LIMITATION OF LIABILITY:** Fast Kitchen Hoods is not liable for economic losses, lost profits, or special, exemplary, punitive, indirect, or consequential damages, including losses resulting from operational downtime.

**WARRANTY EXCLUSIONS:** This warranty does not cover:

1. Alteration, neglect, abuse, misuse, accident, or improper installation.
2. Damage caused during transit or installation.
3. Acts of God (such as fire, flood, or other natural disasters).
4. Damage resulting from improper electrical connections, including low voltage, voltage drops, or the use of extension cords.
5. Routine maintenance tasks.
6. Consequential damages resulting from equipment failure.



Toll free +1 (833) 978 8833  
sales@mckequipment.ca  
Visit [mckonline.ca](http://mckonline.ca) for more details

Quality Kitchen  
Equipment & Supplies



**ELECTRICAL CONNECTION RESPONSIBILITY:** Fast Kitchen Hoods is not responsible for the repair or replacement of components that fail or are damaged due to electrical power issues, including power failures, improper grounding, or the use of extension cords.

**WARRANTY DISCLAIMER:** The two (2) year parts warranty is exclusive and in lieu of all other warranties. Fast Kitchen Hoods disclaims any implied warranties of merchantability or fitness for a particular purpose, as well as any implied warranties of non-infringement.

**What is Not Covered by This Warranty:**

1. Equipment that has not been properly installed or maintained, damage from improper cleaning, and water damage to controls.
2. Equipment that has not been used in an appropriate manner, or has been subject to misuse, neglect, abuse, accident, alteration, negligence, damage during transit, fire, flood, or acts of God.

The warranties described above are exclusive and in lieu of all other warranties. MCK Equipment disclaims any implied warranty of merchantability or fitness for a particular purpose. There are no warranties which extend beyond the description provided herein.

**For any additional inquiries regarding your warranty or to submit a claim, please contact MCK Equipment at +1 (833) 978 8833 or, at [claims@mckequipment.ca](mailto:claims@mckequipment.ca)**



Toll free +1 (833) 978 8833  
 sales@mckequipment.ca  
 Visit mckonline.ca for more details

Quality Kitchen  
 Equipment & Supplies



# CONTACT US

## ALBERTA

### Calgary

Call us: +1 (833) 978 8833  
 sales@mckequipment.ca

### Edmonton

Call us: +1 (833) 978 8833  
 sales@mckequipment.ca

### Red Deer

Call us: +1 (833) 978 8833  
 sales@mckequipment.ca

## BRITISH COLUMBIA

### Vancouver

Call us: +1 (833) 978 8833  
 sales@mckequipment.ca

## SASKATCHEWAN

### Saskatoon

Call us: +1 (833) 978 8833  
 sales@mckequipment.ca

### Regina

Call us: +1 (833) 978 8833  
 sales@mckequipment.ca

### Prince Albert

Call us: +1 (833) 978 8833  
 sales@mckequipment.ca

### Battlefords

Call us: +1 (833) 978 8833  
 sales@mckequipment.ca

## Manitoba

### Winnipeg

Call us: +1 (833) 978 8833  
 sales@mckequipment.ca

## ONTARIO

### Ottawa

Call us: +1 (833) 978 8833  
 sales@mckequipment.ca

### Toronto

Call us: +1 (833) 978 8833  
 sales@mckequipment.ca

## QUEBEC

### Montreal

Call us: +1 (833) 978 8833  
 sales@mckequipment.ca

### Quebec City

Call us: +1 (833) 978 8833  
 sales@mckequipment.ca





Toll free +1 (833) 978 8833  
 sales@mckequipment.ca  
 Visit [mckonline.ca](http://mckonline.ca) for more details

Quality Kitchen  
 Equipment & Supplies



# VISIT OUR SHOWROOM:

## SASKATCHEWAN

### Saskatoon

3603 Millar Ave #4,  
 Saskatoon, SK S7P 0B2  
 +1 (833) 978 8833  
[saskatoon@mckequipment.ca](mailto:saskatoon@mckequipment.ca)



# SHOP OR QUOTE ONLINE

Discover unbeatable deals and premium kitchen equipment at MCK Equipment. Visit our website to shop online, or request a quote today. **Equip and build your dreamed restaurant kitchen and bar, start your journey with us now!**  
[mckonline.ca](http://mckonline.ca)  
[mckonline.ca/shop](http://mckonline.ca/shop)





*Elevate your restaurant, kitchen or bar with  
equipment designed and delivered straight to you*

---



**VISIT OUR SHOWROOM :**

**SASKATOON, SASKATCHEWAN** 3603 Millar  
Ave #4, Saskatoon, SK S7P 0B2

Call us toll free +1 833 978 8833  
Email: [sales@mckequipment.ca](mailto:sales@mckequipment.ca)  
Website: [mckonline.ca](http://mckonline.ca)